

# MA3

series

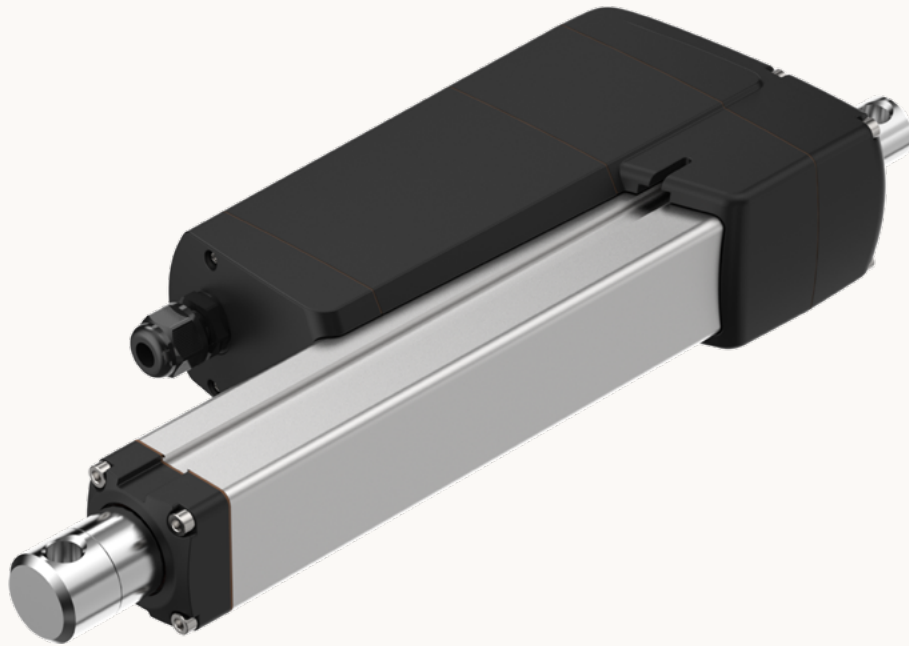

## Product Segments

- **Industrial Motion**

TiMOTION's MA3 was specifically designed for heavy-duty applications and harsh working environments that require durability. Examples of applications suitable for the MA3: Agricultural equipment such as spreaders, harvesters, grain handlers, combines, and tractors. Commercial and industrial applications such as commercial lawn mowers, scrubbers and sweepers, and material handling equipment.

### General Features

Max. load	16,000N (push/pull)
Max. speed at max. load	8.9mm/s
Max. speed at no load	172.5mm/s
Retracted length	≥ Stroke + 200mm
IP rating	IP69K
Certificate	UL73, EMC
Stroke	25~1000mm
Output signals	Hall sensors, POT, adjustable Reed switch
Voltage	12/24V DC; 12/24V DC (thermal control)
Operational temperature range	-40°C~+85°C
Operational temperature range at full performance	+5°C~+45°C
Manual drive	

**Drawing**

Standard Dimensions  
(mm)

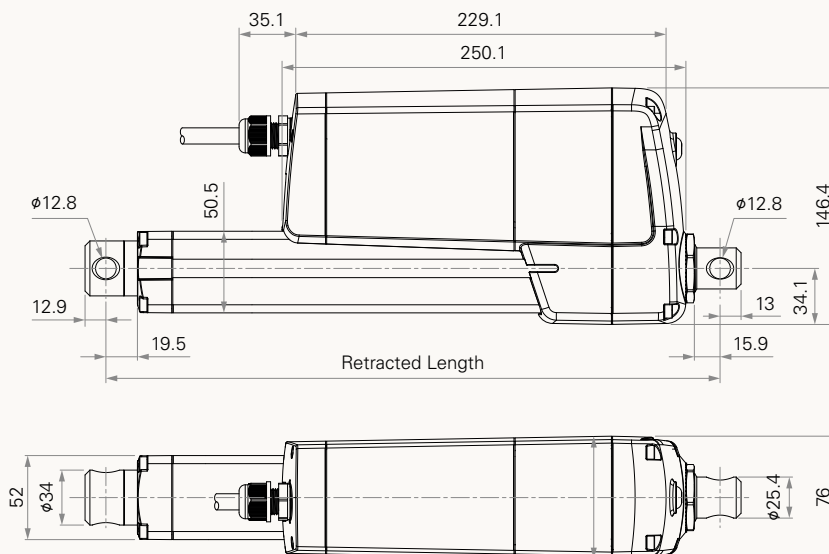

**Load and Speed**

CODE	Load (N)		Self Locking Force (N)	Duty Cycle	Typical Current (A)		Typical Speed (mm/s)	
	Push	Pull			No Load 24V DC	With Load 24V DC	No Load 24V DC	With Load 24V DC
<b>Motor Speed (5100RPM)</b>								
<b>F</b>	500	500	650	25%	2.5	10.2	172.5	152.0
<b>K</b>	1000	1000	1300	25%	2.5	10.2	86.0	76.0
<b>G</b>	2500	2500	3250	25%	2.5	10.5	43.0	38.0
<b>H</b>	5000	5000	6500	25%	2.5	10.2	21.5	19.0
<b>M</b>	7500	7500	9750	25%	2.5	11.4	14.0	12.4
<b>N</b>	10000	10000	13000	25%	2.5	11.3	10.5	9.3
<b>J</b>	16000	16000	20800	15%	2.5	12.6	7.2	6.2
<b>P</b>	7500	7500	9750	25%	3.0	12.0	21.3	18.2
<b>Q</b>	10000	10000	13000	25%	3.0	10.5	14.2	12.5
<b>R</b>	16000	16000	20800	15%	3.0	13.0	10.6	8.9

**Note**

- 1 Please refer to the approved drawing for the final authentic value.
- 2 This self-locking force level is reached only when a short circuit is applied on the terminals of the motor. All the TiMOTION control boxes have this feature built-in.
- 3 The current & speed in table are tested with 24V DC motor. With a 12V DC motor, the current is approximately twice the current measured in 24V DC; speed will be similar for both voltages.
- 4 The current & speed in table are tested when the actuator is extending under push load.
- 5 The current & speed in table and diagram are tested with a stable 24V DC power supply.
- 6 With load, noise level ≤ 78dBA (by TiMOTION test standard, ambient noise level ≤ 36dBA).
- 6 Standard stroke: Min. 25mm, Max. please refer to below table.

CODE	Load (N)	Max Stroke (mm)
<b>F, K, G</b>	≤ 2500	1000
<b>H</b>	≤ 5000	800
<b>M, N, P, Q</b>	≤ 10000	600
<b>J, R</b>	≤ 16000	400

**Performance Data (24V DC Motor)**

Motor Speed (5100RPM)

Speed vs. Load

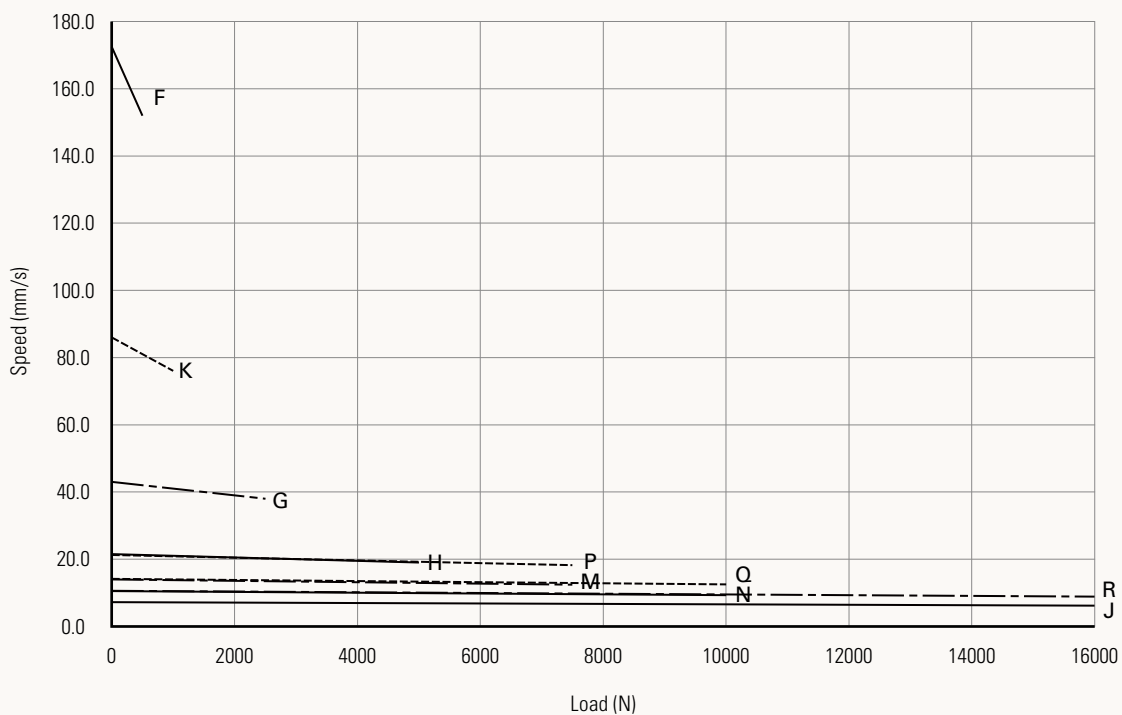

Current vs. Load

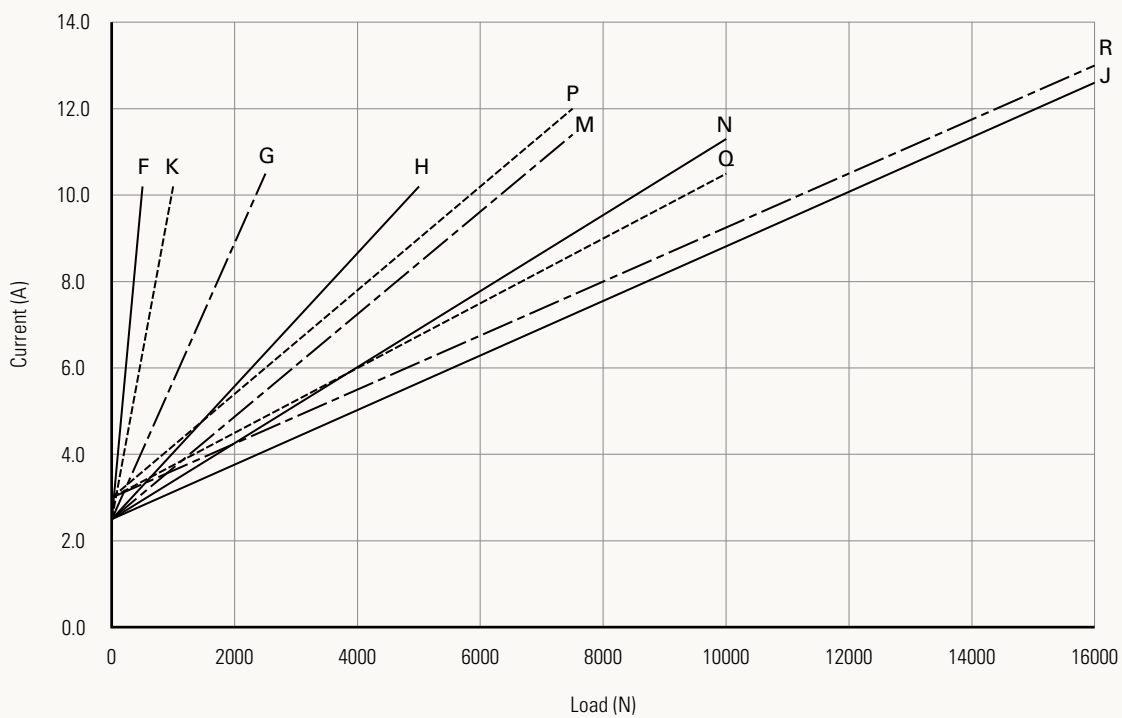

<b>Hardware System</b>	N = Without driver board			
<b>Voltage</b>	1 = 12V DC	2 = 24V DC	6 = 12V DC, thermal switch	5 = 24V DC, thermal switch
<b>Load &amp; Speed</b>	<a href="#">See page 2</a>			
<b>Brake</b>	S = Mechanical brake			
<b>Stroke (mm)</b>	<a href="#">See page 2</a>			
<b>Retracted Length (mm)</b>	<a href="#">See page 5</a>			
<b>Rear Attachment (mm)</b> <a href="#">See page 6</a>	1 = #45 Steel, slotless, hole 10.2 2 = #45 Steel, slotless, hole 12.8 3 = #45 Steel, U clevis, slot 8.2, depth 15.0, hole 10.2 4 = #45 Steel, U clevis, slot 8.2, depth 15.0, hole 12.8		5 = Stainless Steel, slotless, hole 10.2 6 = Stainless Steel, slotless, hole 12.8 7 = Stainless Steel, U clevis, slot 8.2, depth 15.0, hole 10.2 8 = Stainless Steel, U clevis, slot 8.2, depth 15.0, hole 12.8	
<b>Front Attachment (mm)</b> <a href="#">See page 6-7</a>	1 = #45 Steel, slotless, hole 10.2 2 = #45 Steel, slotless, hole 12.8 3 = #45 Steel, U clevis, slot 8.2, depth 15.0, hole 10.2 4 = #45 Steel, U clevis, slot 8.2, depth 15.0, hole 12.8 5 = Stainless Steel, slotless, hole 10.2		6 = Stainless Steel, slotless, hole 12.8 7 = Stainless Steel, U clevis, slot 8.2, depth 15.0, hole 10.2 8 = Stainless Steel, U clevis, slot 8.2, depth 15.0, hole 12.8 K = Rod end bearing, hole 12.8	
<b>Direction of Rear Attachment (Counterclockwise)</b> <a href="#">See page 7</a>	1 = 0°	2 = 45°	3 = 90°	4 = 135°
<b>Function of Limit Switches</b>	1 = Two limit switches cut off the actuator at end of stroke 2 = Two limit switches send signal at end of stroke (signal type: normally closed)			
<b>Adjustable Reed Sensor</b>	0 = Without	1 = Reed sensor*1, tinned leads	2 = Reed sensor*2, tinned leads	
<b>Output Signal</b> <a href="#">See page 8</a>	0 = Without	1 = Mechanical POT	4 = Hall sensor*1	5 = Hall sensor*2
<b>IP Rating</b>	1 = Without 6 = IP66M	7 = IP67 8 = IP68	9 = IP69K	
<b>Cable Exit</b>	1 = Single cable			
<b>A1 / P1 Connector (mm)</b> <a href="#">See page 7</a>	01 = Tinned leads, unsheathed wire 50, stripped wire 4			
<b>A1 / P1 Cable Length (mm)</b>	0500 = 500	1000 = 1000	1500 = 1500	2000 = 2000
<b>P2 Connector</b>	NN = Without			
<b>P2 Cable Length (mm)</b>	0000 = Without			
<b>P3 Connector</b>	NN = Without			
<b>P3 Cable Length (mm)</b>	0000 = Without			
<b>Bus interface</b>	N = Without			

## Retracted Length (mm)

1. Calculate  $A+B+C+D = Y$
2. minimum retracted length is Stroke + Y

Important notice:

Depending on the attachments, the motor cover might interfere with the customer's device when retracted length is between 225~318mm. Please confirm before placing order.

A.		
Front Attach.	Rear Attach.	
	1, 2, 5, 6	3, 4, 7, 8
1, 2, 5, 6	+200	+208
3, 4, 7, 8	+207	+215
K	+225	+233

B.	
Stroke (mm)	Load & speed type(N)
	F, K, G, H, M, N, J
25~150	-
151~200	-
201~250	+10
251~300	+20
301~350	+30
351~400	+40
401~450	+50
451~500	+60
501~550	+70
551~600	+80
601~650	+90
651~700	+100
701~750	+110
751~800	+120
801~850	+130
851~900	+140
901~950	+150
951~1000	+160

C.	
Output Signal	
0, 4, 5	-
1	+18

D.	
Load and Speed	
K, G, H, M, N, J	-
F	+13
P, Q, R	+20

## Rear Attachment (mm)

1 = #45 Steel, slotless, hole 10.2

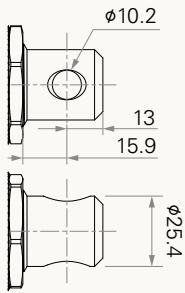

2 = #45 Steel, slotless, hole 12.8

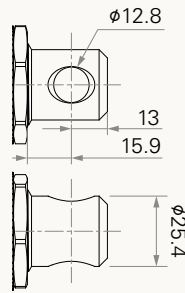

3 = #45 Steel, U clevis, slot 8.2, depth 15.0, hole 10.2

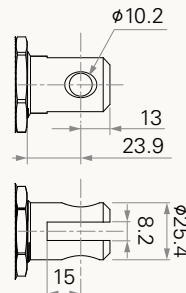

4 = #45 Steel, U clevis, slot 8.2, depth 15.0, hole 12.8

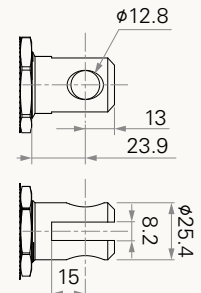

5 = Stainless Steel, slotless, hole 10.2

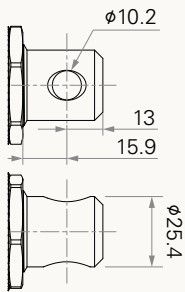

6 = Stainless Steel, slotless, hole 12.8

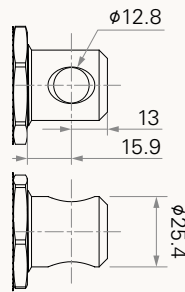

7 = Stainless Steel, U clevis, slot 8.2, depth 15.0, hole 10.2

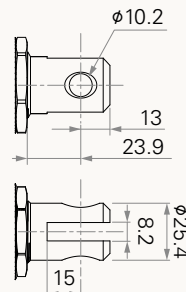

8 = Stainless Steel, U clevis, slot 8.2, depth 15.0, hole 12.8

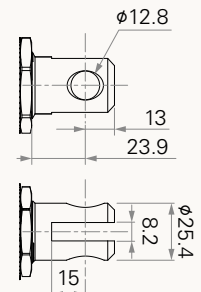

## Front Attachment (mm)

1 = #45 Steel, slotless, hole 10.2

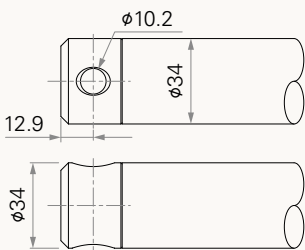

2 = #45 Steel, slotless, hole 12.8

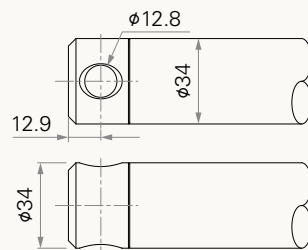

3 = #45 Steel, U clevis, slot 8.2, depth 15.0, hole 10.2

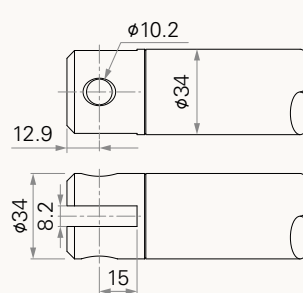

4 = #45 Steel, U clevis, slot 8.2, depth 15.0, hole 12.8

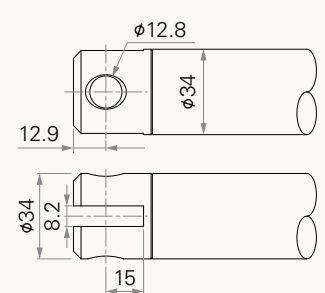

5 = Stainless Steel, slotless, hole 10.2

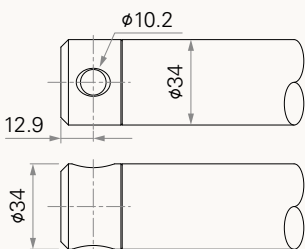

6 = Stainless Steel, slotless, hole 12.8

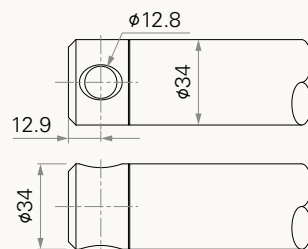

7 = Stainless Steel, U clevis, slot 8.2, depth 15.0, hole 10.2

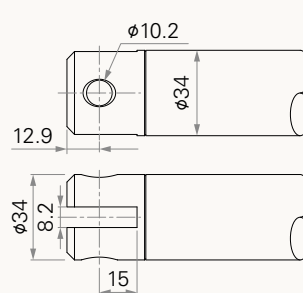

8 = Stainless Steel, U clevis, slot 8.2, depth 15.0, hole 12.8

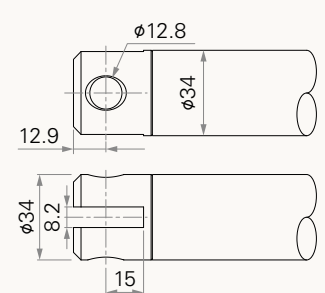

## Front Attachment (mm)

K = Rod end bearing, hole 12.8

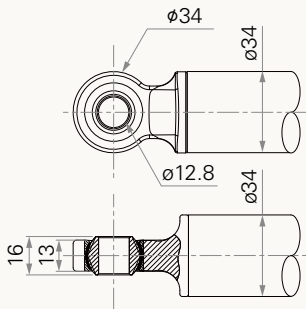

## Direction of Rear Attachment (Counterclockwise)

1 =  $0^\circ$

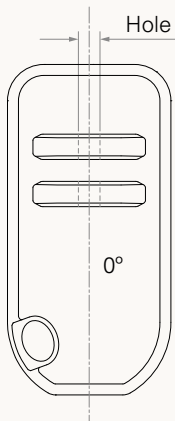

2 =  $45^\circ$

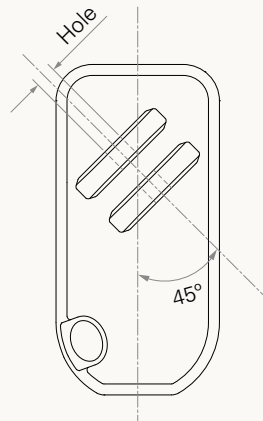

3 =  $90^\circ$

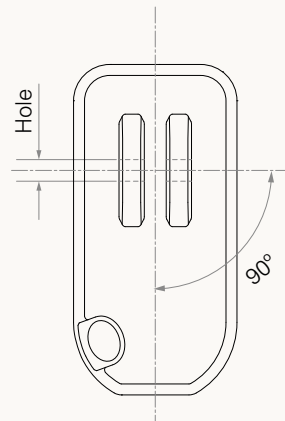

4 =  $135^\circ$

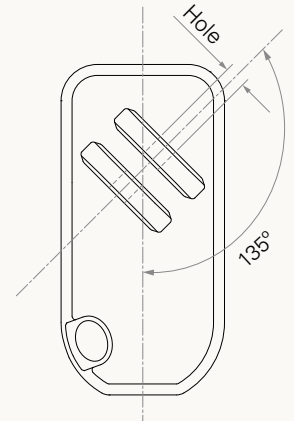

## Connector (mm)

01 = Tinned leads, unsheathed wire 50,  
stripped wire 4

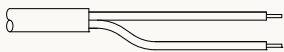

## Output Signals

Wiring Definition			Wire Gauge (AWG)	Output Signal Code				
				0. Without	1. POT	4. Hall sensor*1	5. Hall sensor*2	
without T-Smart	P1	Limit Switches Cut Off the Acuator	● Red	14	extend+	extend+	extend+	extend+
			● Black	14	retract+	retract+	retract+	retract+
			● Red	20	-	V-out	+5V	+5V
			○ White	20	-	V-in	S1	S1
			● Blue	20	-	-	-	S2
			● Black	20	-	GND	GND	GND
			● Brown	20	-	-	-	-
			● Orange	20	-	-	-	-
			● Purple	20	-	-	-	-
without T-Smart	P1	Limit Switches Send Signal	● Red	14	extend+	extend+	extend+	extend+
			● Black	14	retract+	retract+	retract+	retract+
			● Red	20	COM	COM	+5V	+5V
			○ White	20	EOS-extended	EOS-extended	S1	S1
			● Blue	20	EOS-retracted	EOS-retracted	-	S2
			● Black	20	-	GND	GND	GND
			● Brown	20	-	V-in	EOS-extended	EOS-extended
			● Orange	20	-	V-out	EOS-retracted	EOS-retracted
			● Purple	20	-	-	COM	COM

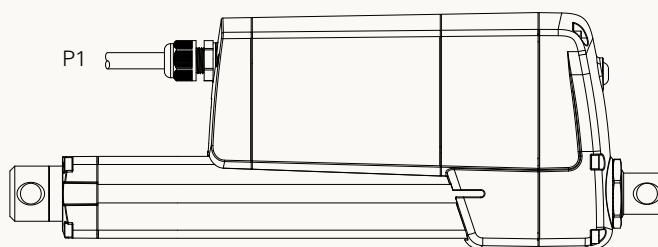

## Terms of Use

The user is responsible for determining the suitability of TiMOTION products for a specific application. TiMOTION products are subject to change without prior notice.