

MA5

series

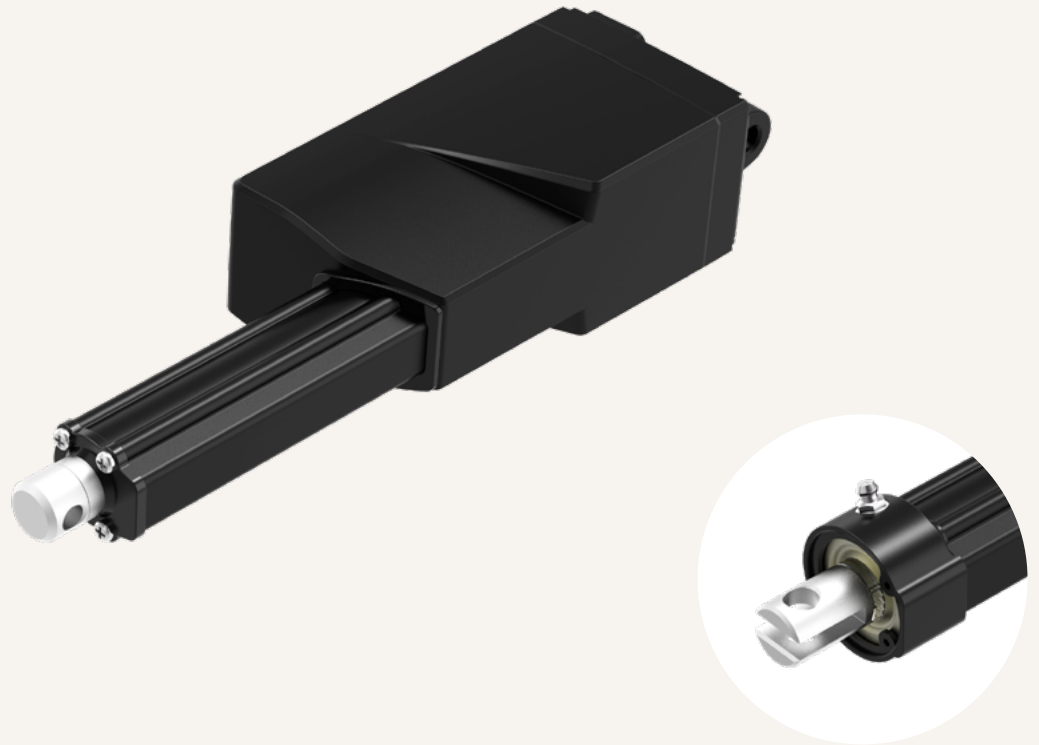

Product Segments

- **Industrial Motion**

TiMOTION's MA5 electric linear actuator is specifically designed for applications that face harsh working environments and require ruggedness and durability. Its IP69K protection can withstand high-pressure water jets, and the ingress of dust and other solid contaminants. The MA5 can also be customized with various feedback options depending on the application requirements; moreover, it can be equipped with a grease nipple to increase the protection degree and life cycle. Suitable applications for MA5 include agricultural equipment, such as valves, spreaders, harvesters, and grain handlers.

General Features

Max. load	3,500N (push); 2,000N (pull)
Max. speed at max. load	2.4mm/s
Max. speed at no load	56.5mm/s
Retracted length	≥ 200mm (depending on chosen options)
IP rating	IP69K
Stroke	20~1000mm
Output signals	Hall sensors, POT
Options	Grease chamber
Operational temperature range	-25°C~+65°C
Operational temperature range at full performance	+5°C~+45°C

Drawing

Standard Dimensions
(mm)

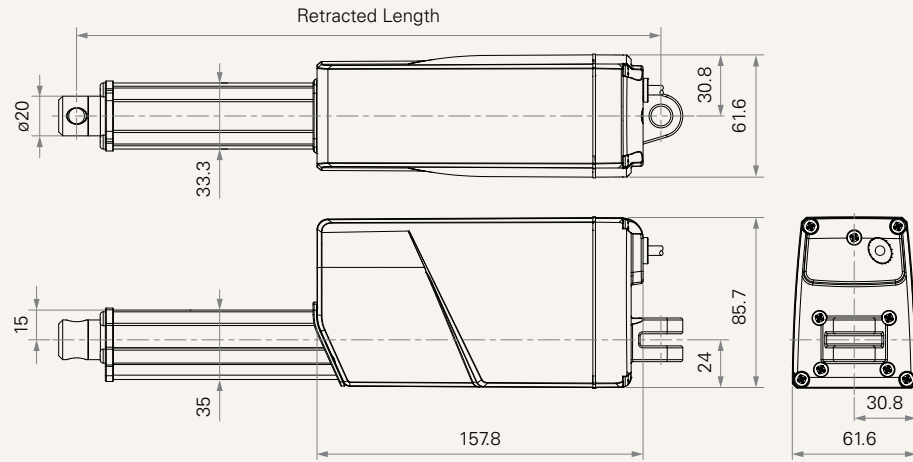

With Grease Chamber
Standard Dimensions
(mm)

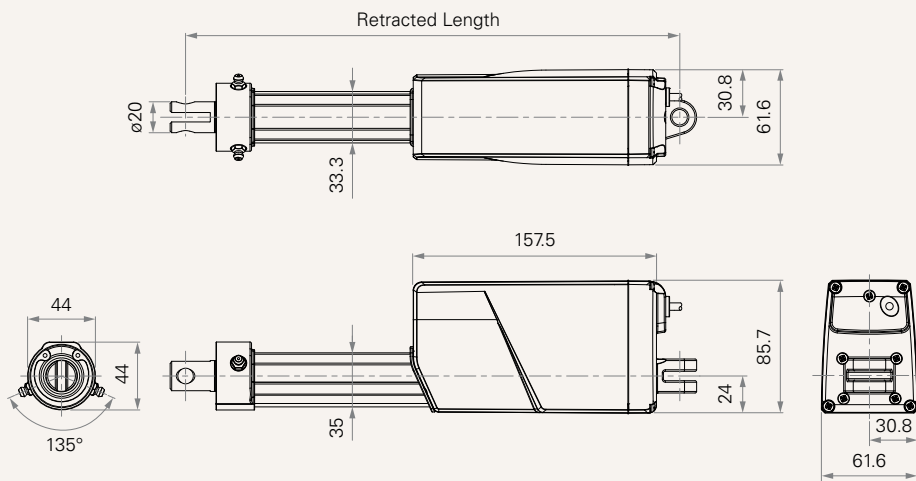

Load and Speed

CODE	Load (N)		Self Locking Force (N)	Typical Current (A)		Typical Speed (mm/s)	
	Push	Pull		No Load 24V DC	With Load 24V DC	No Load 24V DC	With Load 24V DC
Motor Speed (5200RPM, duty cycle 25%)							
A	250	250	250	1.2	2.3	43.0	36.0
B	500	500	500	1.1	2.3	25.8	23.0
C	1000	1000	1000	1.1	2.3	14.0	11.8
D	1500	1500	1500	1.0	2.2	9.0	8.0
E	2000	2000	2000	1.0	2.2	7.1	6.2
W	500	500	500	1.3	5.0	54.0	35.0
Motor Speed (6600RPM, duty cycle 25%)							
F	250	250	250	1.6	2.8	56.5	45.0
G	500	500	500	1.5	2.8	32.5	28.5
H	1000	1000	1000	1.5	2.8	16.5	14.3
K	1500	1500	1500	1.3	2.8	11.1	10.0
L	2000	2000	2000	1.3	2.8	8.8	7.7
Motor Speed (3800RPM, duty cycle 25%)							
S	3500	2000	3500	0.9	2.8	3.2	2.4
Motor Speed (2200RPM, duty cycle 25%)							
T	2000	2000	2000	0.3	1.2	3.2	2.4

Note

- 1 Please refer to the approved drawing for the final authentic value.
- 2 This self-locking force level is reached only when a short circuit is applied on the terminals of the motor. All the TiMOTION control boxes have this feature built-in.
- 3 The current & speed in table are tested with 24V DC motor. With a 12V DC motor, the current is approximately twice the current measured in 24V DC; speed will be similar for both voltages.
- 4 The current & speed in table are tested when the actuator is extending under push load.
- 5 The current & speed in table and diagram are tested with TiMOTION control boxes, and there will be around 10% tolerance depending on different models of the control box. (Under no load condition, the voltage is around 32V DC. At rated load, the voltage output will be around 24V DC)
- 6 Standard stroke: Min. ≥ 20 mm, Max. please refer to below table.

CODE	Load (N)	Max Stroke (mm)
A, F	≤ 250	1000
B, G, W	≤ 750	800
C, H	≤ 1000	600
D, K	≤ 1500	500
E, L, T	≤ 2000	450
S	≤ 3500	300

Performance Data (24V DC Motor)

Motor Speed (5200RPM)

Speed vs. Load

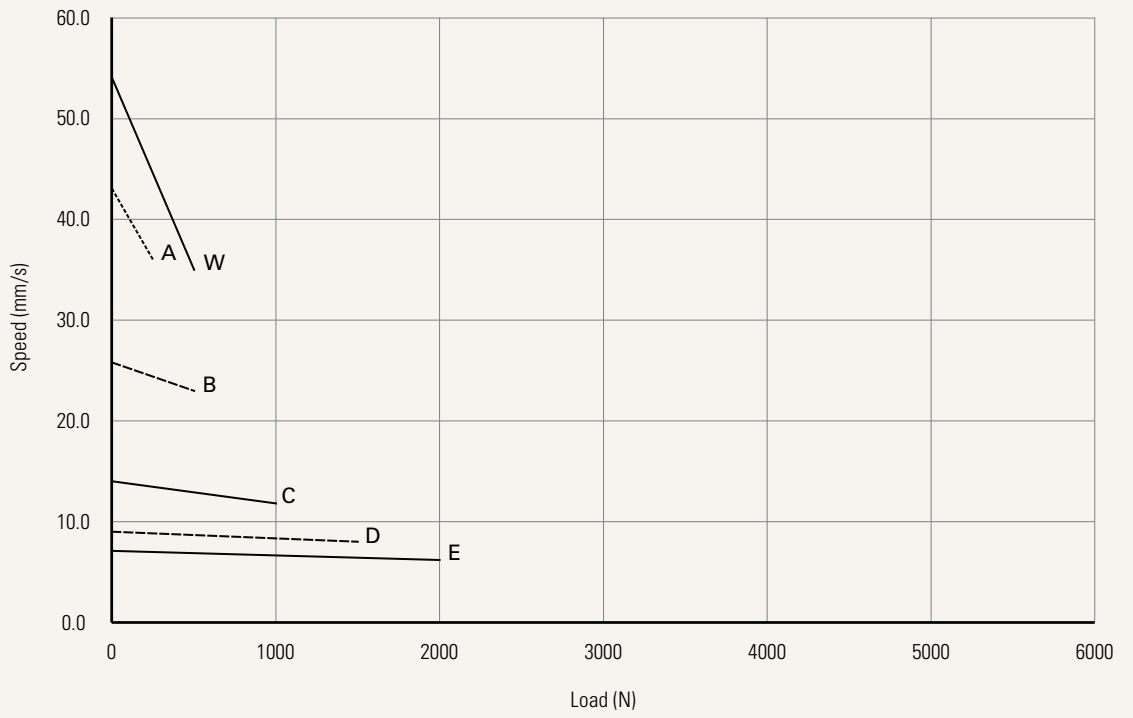

Current vs. Load

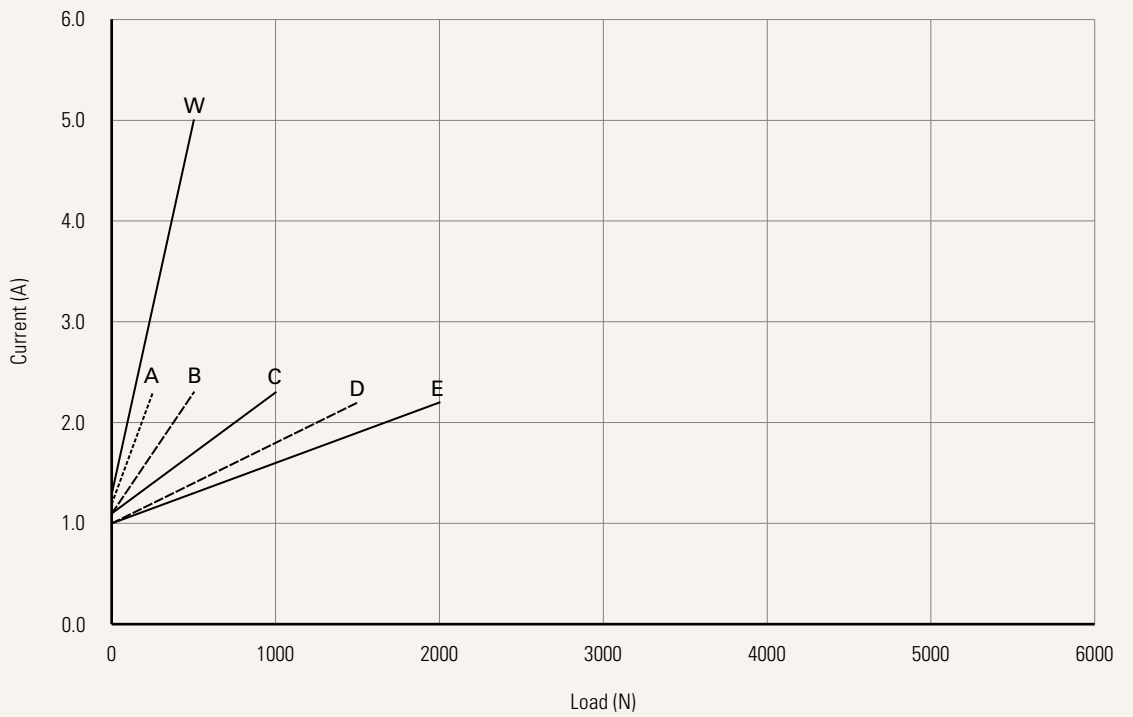

Performance Data (24V DC Motor)

Motor Speed (6600RPM)

Speed vs. Load

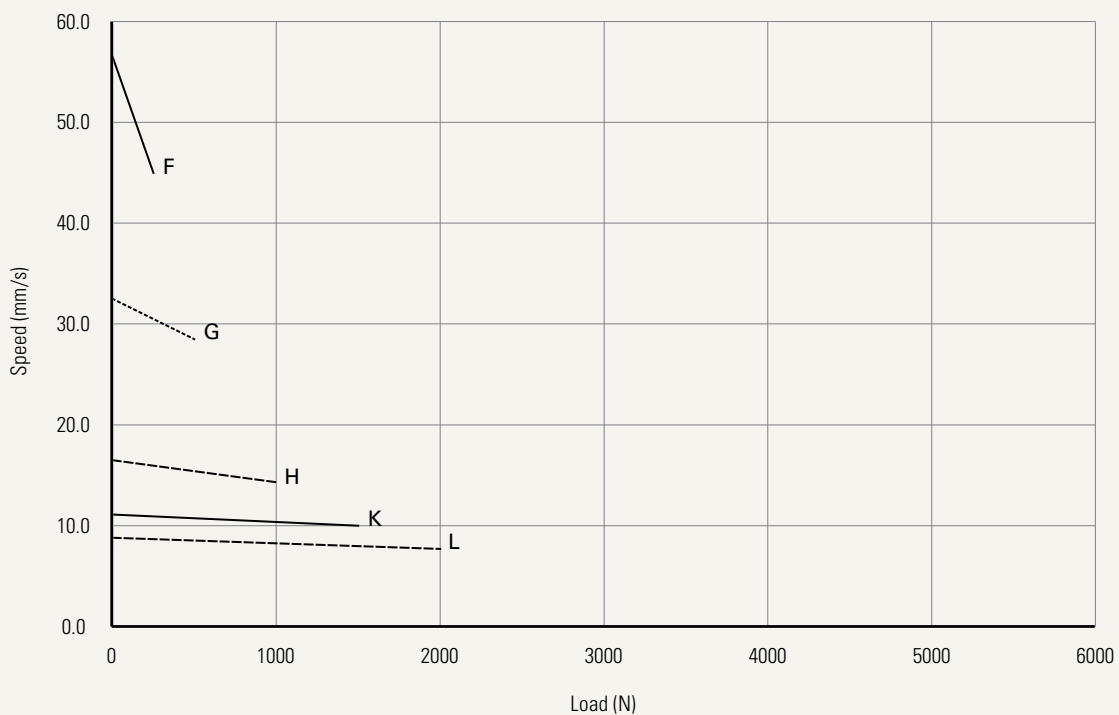

Current vs. Load

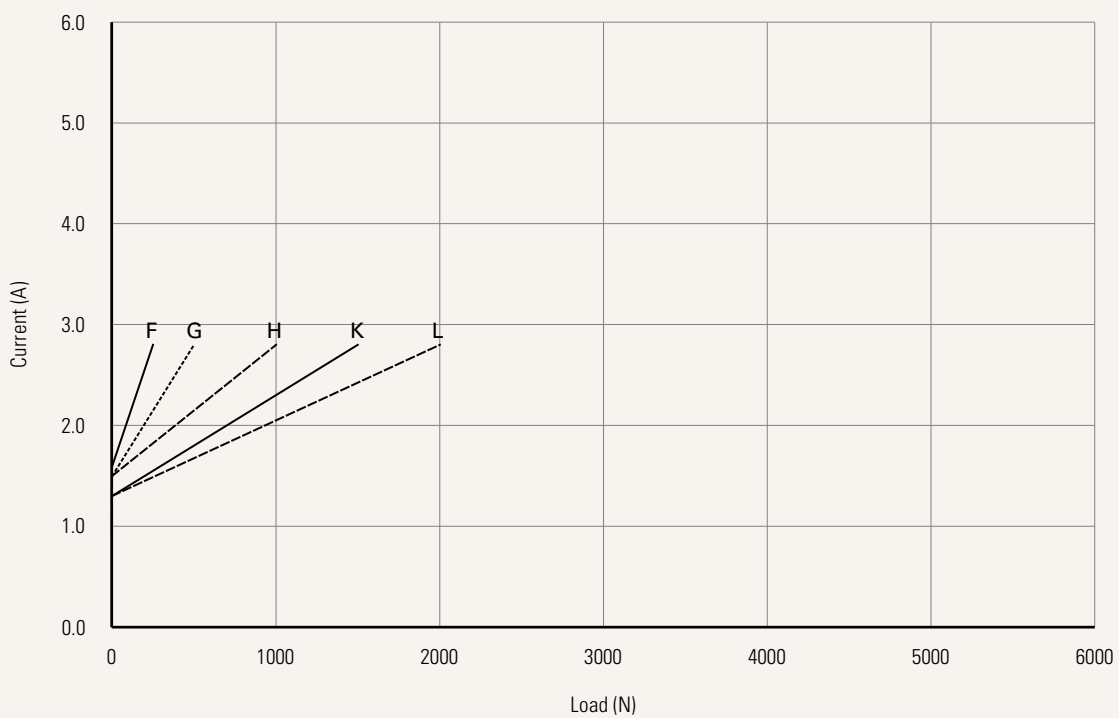

Performance Data (24V DC Motor)

Motor Speed (3800RPM)

Speed vs. Load

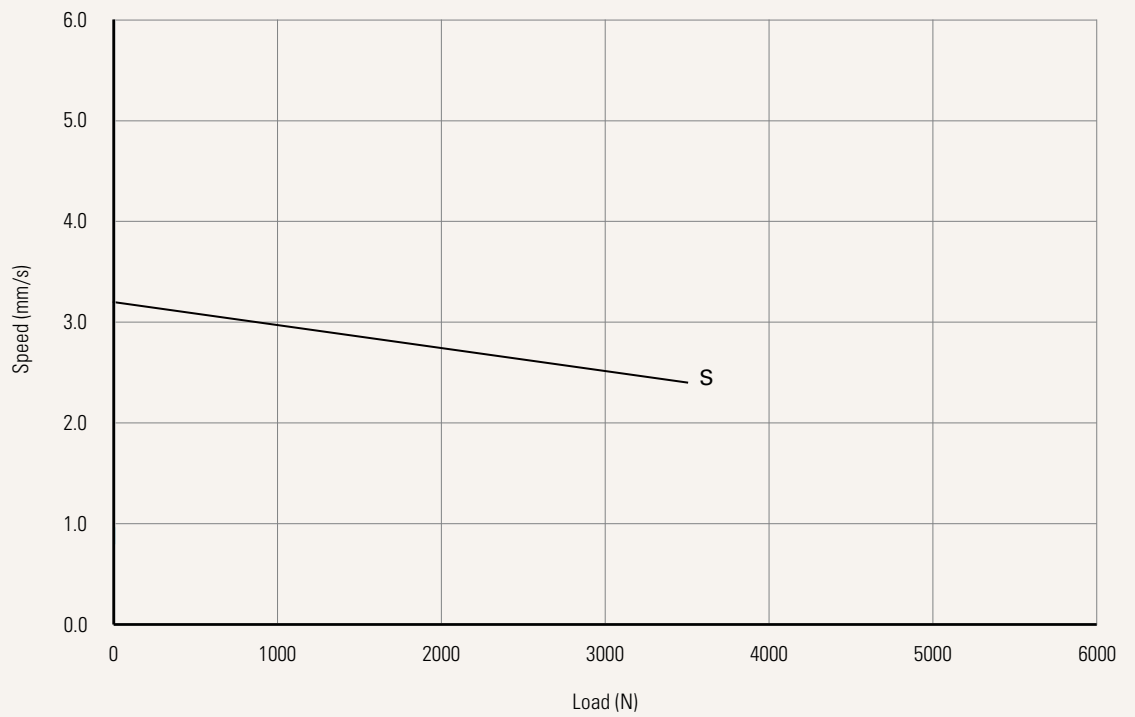

Current vs. Load

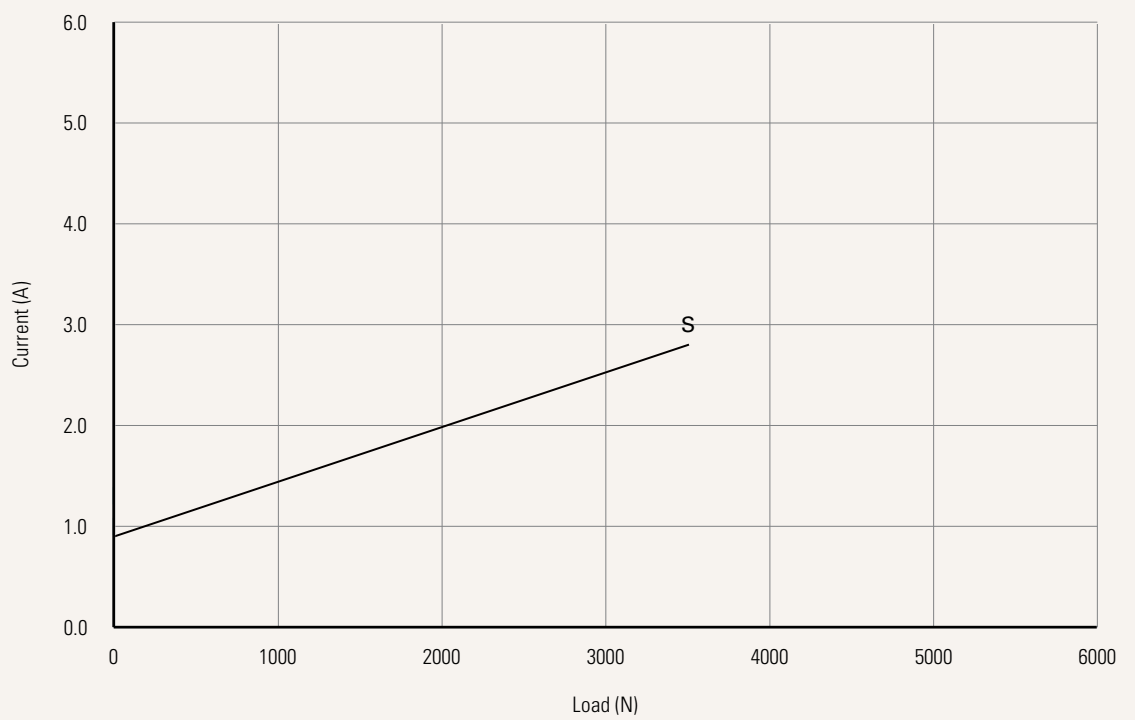

Performance Data (24V DC Motor)

Motor Speed (2200RPM)

Speed vs. Load

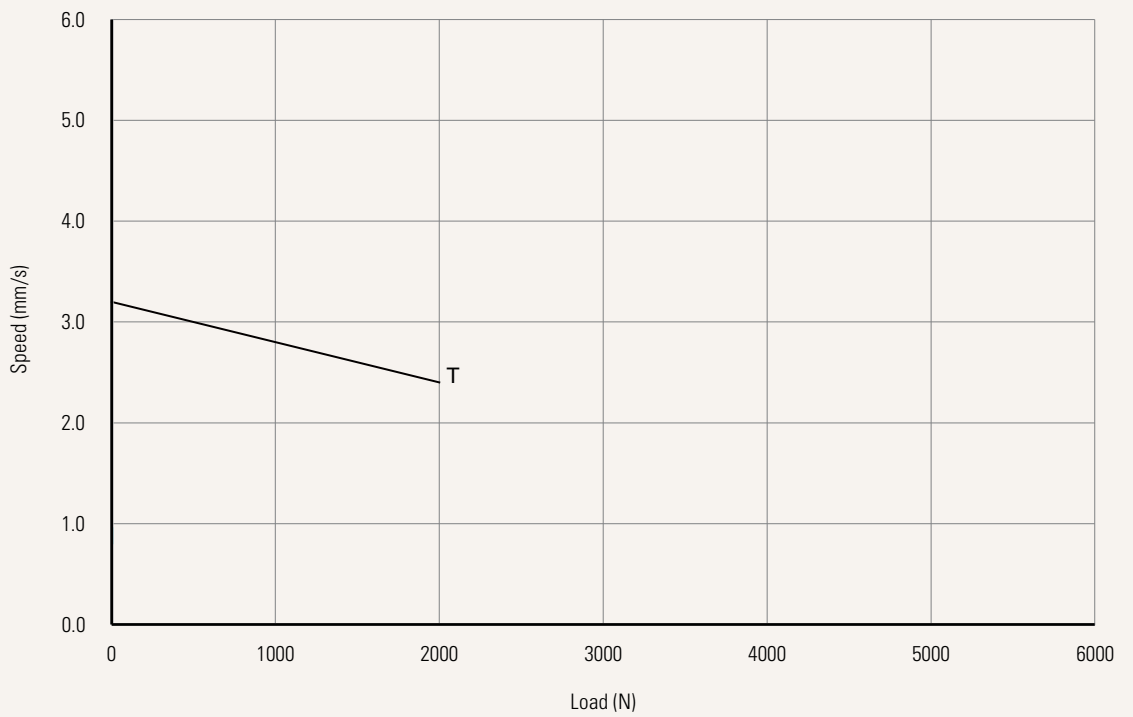

Current vs. Load

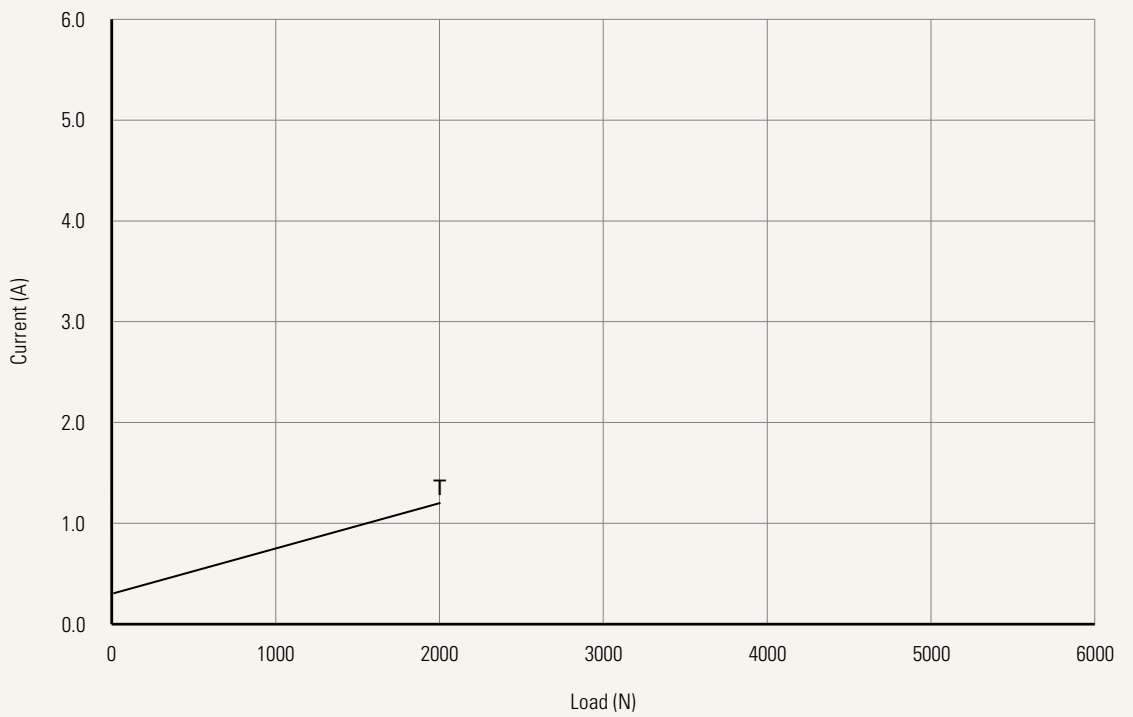

Voltage	1 = 12V DC	2 = 24V DC	5 = 24V DC, PTC	6 = 12V DC, PTC
Load and Speed	See page 3			
Stroke (mm)	See page 3			
Retracted Length (mm)	See page 9			
Rear Attachment (mm) See page 10	4 = Aluminum casting, U clevis, slot 6.0, width 10.5, hole 6.4, one piece casting with gear box		6 = Aluminum casting, U clevis, slot 6.0, width 10.5, hole 10.1, one piece casting with gear box	
	5 = Aluminum casting, U clevis, slot 6.0, width 10.5, hole 8.0, one piece casting with gear box			
Front Attachment (mm) See page 10	1 = Aluminum casting, hole 6.4		4 = Aluminum CNC, U clevis, slot 6.0, depth 16.0, hole 6.4	
	2 = Aluminum casting, hole 8.0		5 = Aluminum CNC, U clevis, slot 6.0, depth 16.0, hole 8.0	
	3 = Aluminum CNC, U clevis, slot 6.0, depth 16.0, hole 10.0			
Direction of Rear Attachment (Counterclockwise) See page 10	1 = 90°		2 = 0°	
Functions for Limit Switches See page 11	1 = Two switches at full retracted / extended positions to cut current			
	2 = Two switches at full retracted / extended positions to cut current + third one in between to send signal			
	3 = Two switches at full retracted / extended positions to send signal			
	4 = Two switches at full retracted / extended positions to send signal + third one in between to send signal			
Output Signals	0 = Without	1 = POT	5 = Hall sensor * 2	
Connector See page 11	1 = DIN 6P, 90° plug		2 = Tinned leads	
Cable Length (mm)	1 = Straight, 300	2 = Straight, 600	3 = Straight, 1000	
IP Rating	6 = IP66D		9 = IP69K	
Wiper Set & Grease Nipple	0 = Normal wiper, without grease chamber			
	1 = Enhanced wiper set, with grease chamber, grease nipple * 1			
	2 = Enhanced wiper set, with grease chamber, grease nipple * 2			
	3 = Enhanced wiper set, with grease chamber, without grease nipple			

Retracted Length (mm)

1. Calculate $A+B+C = Y$
2. Retracted length needs to \geq Stroke + Y
3. The total Retracted length calculated must be equal or longer than below minimum value
 - (1) When choosing the wiper set #0: And the front attachment is #1, #2, min retracted length \geq 200mm, And the front attachment is #3, #4, #5, min retracted length \geq 212mm
 - (2) When choosing the wiper set #1, #2, #3: And the front attachment is #1, #2 min retracted length \geq 238mm, And the front attachment is #3, #4, #5 min retracted length \geq 250mm

A. Front Attachment

1, 2	+112
3, 4, 5	+124

B. Load V.S. Stroke

Stroke (mm)	Load (N)	
	< 3500	= 3500
20 ~150	-	+5
151~200	+2	+7
201~250	+2	+7
251~300	+2	+7
301~350	+12	+17
351~400	+22	+27
401~450	+32	+37
451~500	+42	+47
501~550	+52	+57
551~600	+62	+67
601~650	+72	+77
651~700	+82	+87
701~750	+92	+97
751~800	+102	+107
801~850	+112	+117
851~900	+122	+127
901~950	+132	+137
951~1000	+142	+147

C. Output Signals

0, 5	-
1	+30

D. Wiper Set & Grease Nipple

0	-
1, 2, 3	+10

Rear Attachment (mm)

4 = Aluminum casting, U clevis, slot 6.0, width 10.5, hole 6.4, one piece casting with gear box

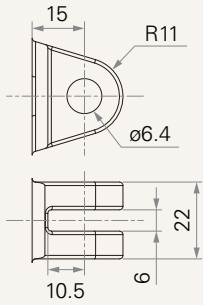

5 = Aluminum casting, U clevis, slot 6.0, width 10.5, hole 8.0, one piece casting with gear box

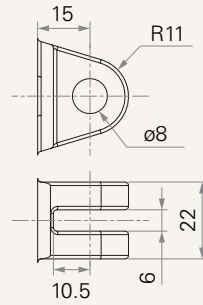

6 = Aluminum casting, U clevis, slot 6.0, width 10.5, hole 10.1, one piece casting with gear box

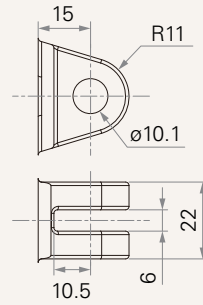

Front Attachment (mm)

1 = Aluminum casting, hole 6.4

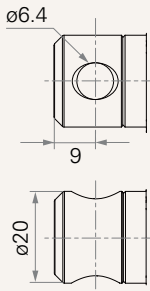

2 = Aluminum casting, hole 8.0

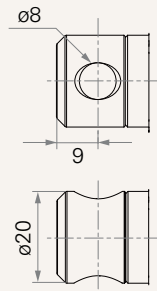

3 = Aluminum CNC, U clevis, slot 6.0, depth 16.0, hole 10.0

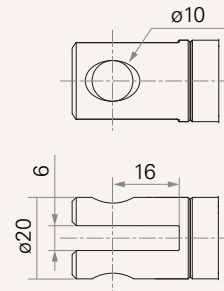

4 = Aluminum CNC, U clevis, slot 6.0, depth 16.0, hole 6.4

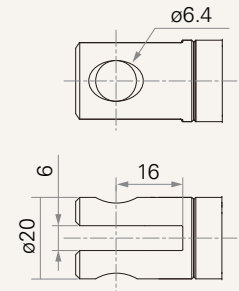

5 = Aluminum CNC, U clevis, slot 6.0, depth 16.0, hole 8.0

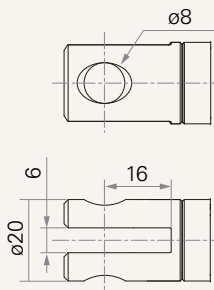

Direction of Rear Attachment (Counterclockwise)

1 = 90°

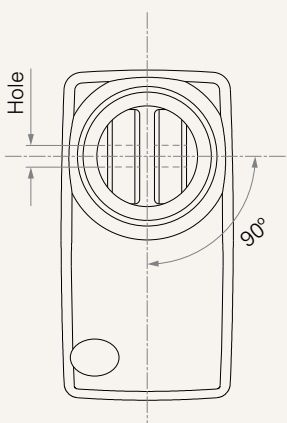

2 = 0°

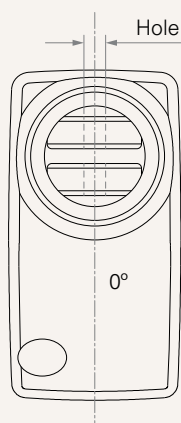

Functions for Limit Switches

Wire Definitions

CODE	Pin					
	● 1 (Green)	● 2 (Red)	○ 3 (White)	● 4 (Black)	● 5 (Yellow)	● 6 (Blue)
1	extend (VDC+)	N/A	N/A	N/A	retract (VDC+)	N/A
2	extend (VDC+)	N/A	middle switch pin B	middle switch pin A	retract (VDC+)	N/A
3	extend (VDC+)	common	upper limit switch	N/A	retract (VDC+)	lower limit switch
4	extend (VDC+)	common	upper limit switch	medium limit switch	retract (VDC+)	lower limit switch

Connector

1 = DIN 6P, 90° plug

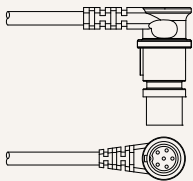

2 = Tinned leads

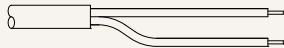

Terms of Use

The user is responsible for determining the suitability of TiMOTION products for a specific application. TiMOTION products are subject to change without prior notice.