

JP3

series



Product Segments

• Industrial Motion

TiMOTION's JP3 series inline linear actuator was designed for low load industrial applications where up to IP69K (static) dust and liquid ingress protection is necessary. It is best suited for applications with visual or compact installation dimension requirements. Hall sensors are optional for the JP3 which allow for synchronization and position feedback.

The JP3 offers stroke lengths from 20 to 1000mm and delivers up to 2,000N of force, making it ideal for compact systems requiring moderate push or pull performance. With speeds up to 23.5mm/s at no load, and UL73 certification, this IP69K linear actuator ensures both efficiency and compliance. Operating within -5°C to +65°C, JP3 is ideally for mobile equipment and agricultural machinery, where compactness and outdoor durability are essential.

General Features

Max. load	2,000N (push/pull)
Max. speed at max. load	3.5mm/s
Max. speed at no load	23.5mm/s
Retracted length	≥ Stroke + 217mm
IP rating	IP69K (static)
Certificate	UL73
Stroke	20~1000mm
Output signals	NPN Hall sensor (5~36V input) * 2
Voltage	12/24V DC; 12/24V DC (PTC)
Color	Black, grey
Operational temperature range	-5°C~+65°C
Operational temperature range at full performance	+5°C~+45°C
Storage temperature range	-40°C~+70°C

Drawing

Standard Dimensions
(mm)

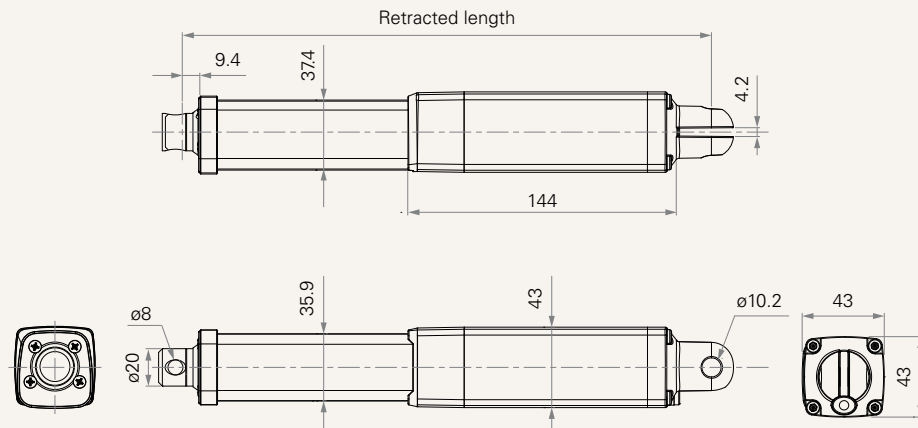

Load and Speed

CODE	Load (N)		Self Locking Force (N)	Typical Current (A)		Typical Speed (mm/s)		Typical Current (A)		Typical Speed (mm/s)	
	Push	Pull		No Load 24V DC	With Load 24V DC	No Load 24V DC	With Load 24V DC	No Load 12V DC	With Load 12V DC	No Load 12V DC	With Load 12V DC
Motor Speed (5600RPM, Duty Cycle 10%)											
B	2000	2000	2000	1.5	3.3	7.0	4.5	2.5	6.5	7.0	3.5
C	1500	1500	1000	1.5	3.3	10.0	6.5	2.5	6.5	10.0	6.5
D	1000	1000	700	1.5	3.0	14.5	9.8	2.5	6.0	14.5	8.5
E	500	500	500	1.5	3.0	23.5	19.0	2.5	6.0	23.5	19.0

Note

- 1 Please refer to the approved drawing for the final authentic value.
- 2 This self-locking force level is reached only when a short circuit is applied on the terminals of the motor. All the TiMOTION control boxes have this feature built-in. The self-locking force is a minimum value and can be actually higher.
- 3 The current & speed in table are tested with 24V DC motor. With a 12V DC motor, the current is approximately twice the current measured in 24V DC; speed will be similar for both voltages.
- 4 The current & speed in table are tested when the actuator is extending under push load.
- 5 The current & speed in table and diagram are tested with a stable 24V DC power supply.
- 6 Without load, noise level ≤ 65 dBA (by TiMOTION test standard, ambient noise level ≤ 36 dBA)
- 7 Standard stroke: Min. ≥ 20 mm, Max. please refer to below table

CODE	Load (N)	Max Stroke (mm)
B	2000	500
C	1500	600
D	1000	800
E	500	1000

Performance Data (24V DC Motor)

Motor Speed (5600RPM, Duty Cycle 10%)

Speed vs. Load

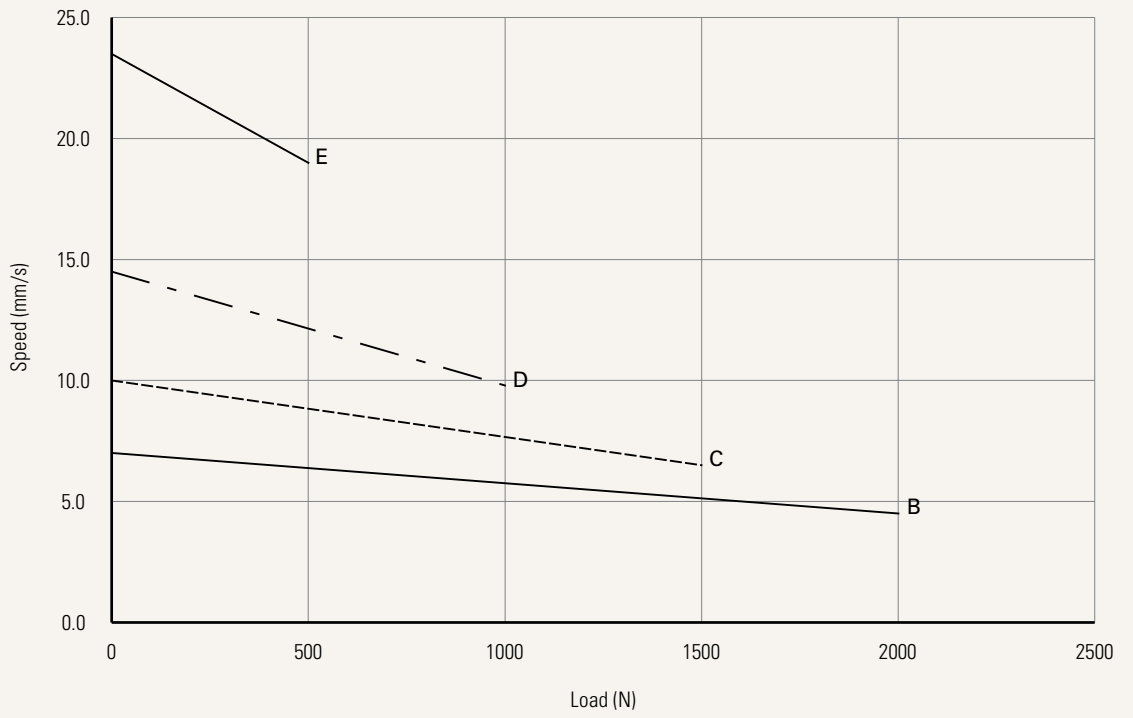

Current vs. Load

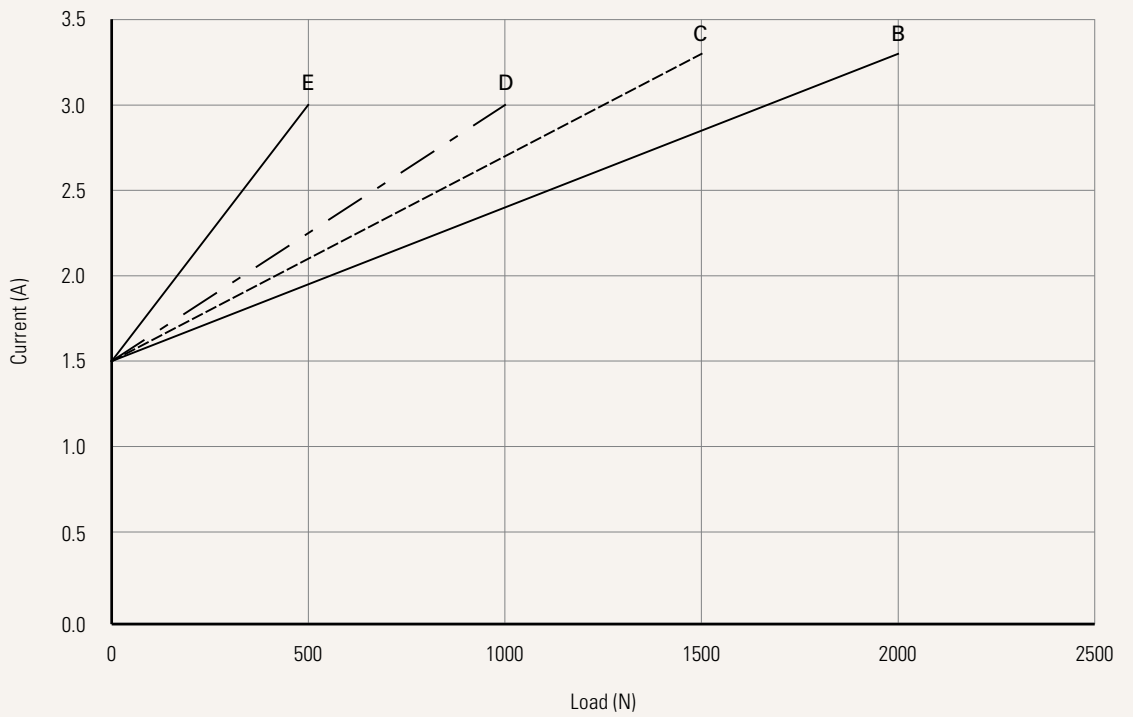

Performance Data (12V DC Motor)

Motor Speed (5600RPM, Duty Cycle 10%)

Speed vs. Load

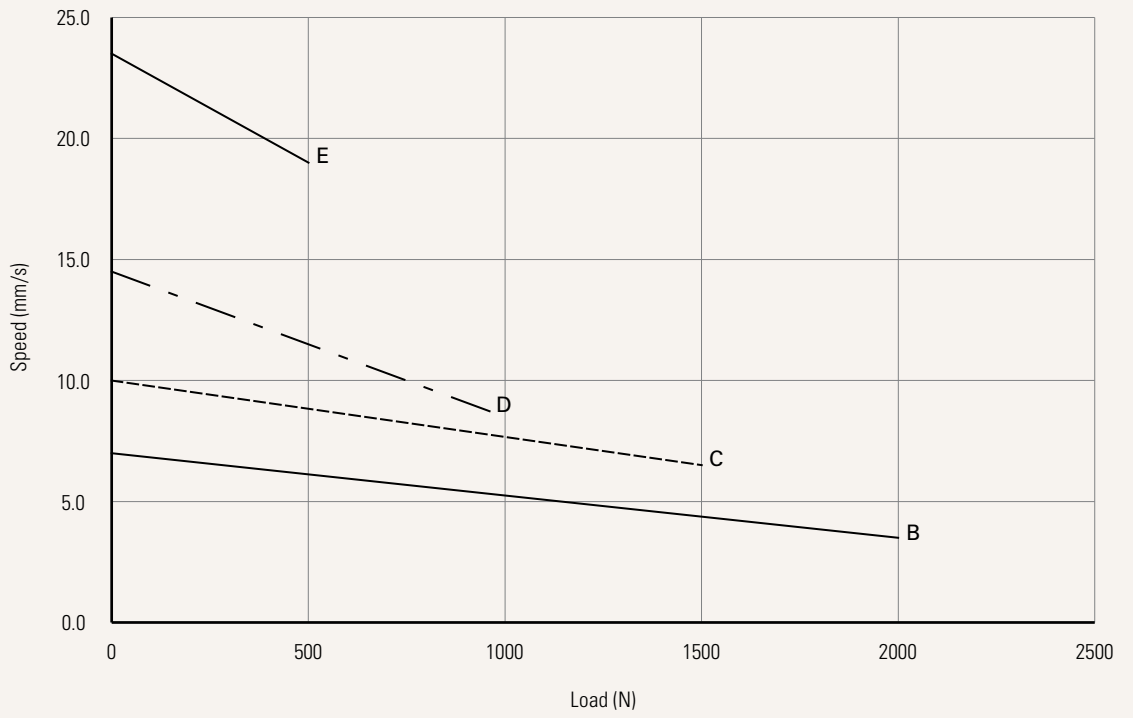

Current vs. Load

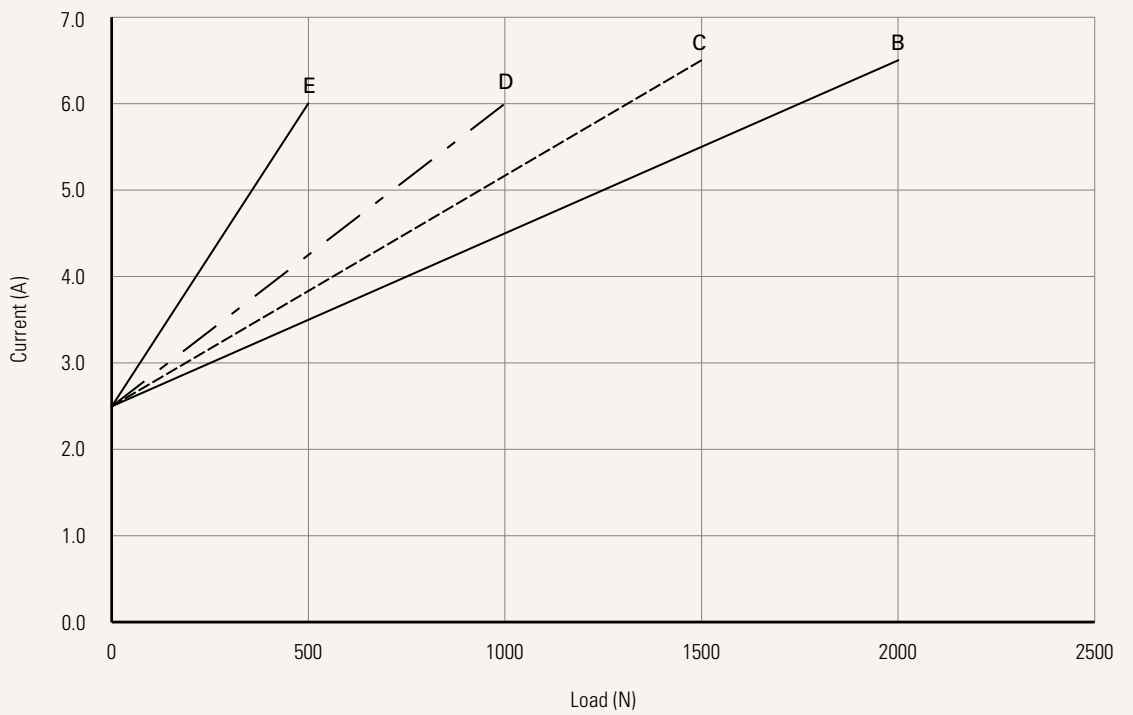

Voltage	1 = 12V DC	2 = 24V DC	5 = 24V DC, PTC	6 = 12V DC, PTC
See page 8				
Load and Speed	See page 2			
Stroke (mm)	See page 2			
Retracted Length (mm)	See page 6			
Rear Attachment (mm)	1 = Aluminum, U clevis, slot 4.2, depth 18.0, hole 10.2			
See page 7				
Front Attachment (mm)	1 = Aluminum, slotless, hole 6.4		4 = Aluminum, U clevis, slot 6.0, depth 13.0, hole 6.4	
See page 7	2 = Aluminum, slotless, hole 8.0		5 = Aluminum, U clevis, slot 6.0, depth 13.0, hole 8.0	
	3 = Aluminum, U clevis, slot 6.0, depth 13.0, hole 10.0		6 = Aluminum, hole 10.0	
Direction of Rear Attachment (Counterclockwise)	1 = 0°			
See page 8				
Color	1 = Black	2 = Pantone 428C		
IP Rating	1 = Without	3 = IP66	6 = IP66M	8 = IP69K
	2 = IP54	5 = IP66W	7 = IP68	
Special Function of Spindle Subassembly	0 = Without (Standard)			
Function of Limit Switches	1 = Two micro switches cut off the actuator at end of stroke			
See page 9	2 = Two micro switches cut off the actuator at end of stroke + third one in between sends signal			
	3 = Two micro switches send signal at end of stroke			
	4 = Two micro switches send signal at end of stroke + third one in between sends signal			
Output Signal	0 = Without		N = NPN Hall sensor (5-36V input) * 2	
Connector	1 = DIN 6P, 90° plug	2 = Tinned leads		
See page 8				
Cable Length (mm)	0 = Straight, 100	1 = Straight, 500	3 = Straight, 1000	

Retracted Length (mm)

1. Calculate $A+B+C = Y$
2. Retracted length needs to \geq Stroke + Y

A. Front Attachment

1, 2, 6	+217
3, 4, 5	+230

B. Stroke (mm)

20~150	-
151~200	-
201~250	+5
251~300	+10
301~350	+15
351~400	+20
401~450	+25
451~500	+30
501~550	+35
551~600	+40
601~650	+45
651~700	+50
701~750	+55
751~800	+60
801~850	+65
851~900	+70
901~950	+75
951~1000	+80

C. Output Signal

0	-
N	+13

Rear Attachment (mm)

1 = Aluminum, U clevis, slot 4.2, depth 18.0, hole 10.2

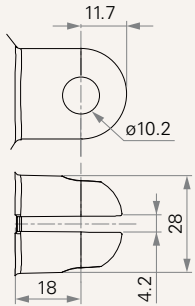

Front Attachment (mm)

1 = Aluminum, slotless, hole 6.4

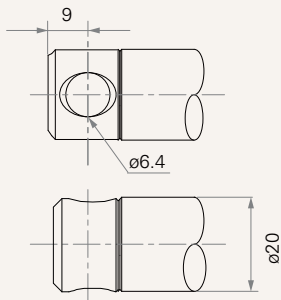

2 = Aluminum, slotless, hole 8.0

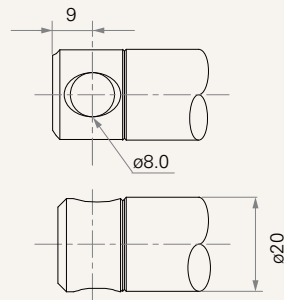

3 = Aluminum, U clevis, slot 6.0, depth 13.0, hole 10.0

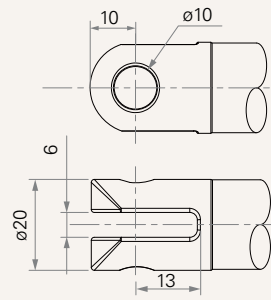

4 = Aluminum, U clevis, slot 6.0, depth 13.0, hole 6.4

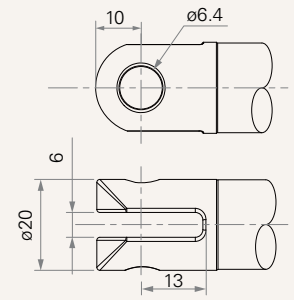

5 = Aluminum, U clevis, slot 6.0, depth 13.0, hole 8.0

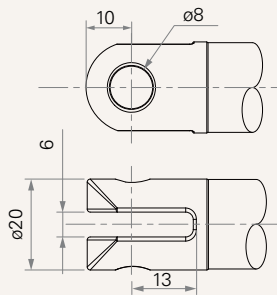

6 = Aluminum, hole 10.0

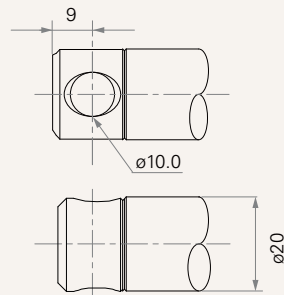

Direction of Rear Attachment (Counterclockwise)

1 = 0°

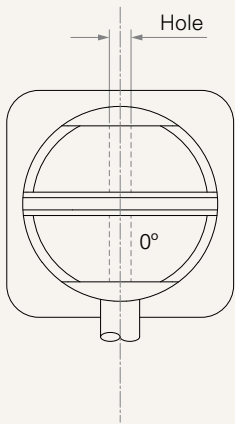

Connector

1 = DIN 6P, 90° plug

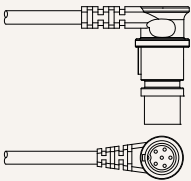

Connector IP = IP66

2 = Tinned leads

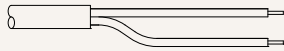

Connector IP = Without IP

Voltage

5 = 24V DC, PTC

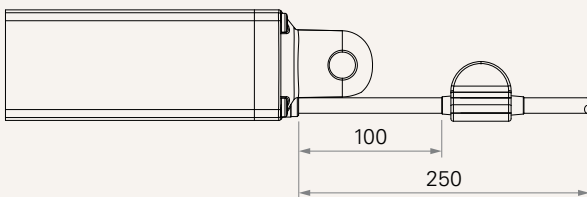

PTC outside the motor; at cable length 100mm,
min total cable = 250mm

Wire Definition

Port Number	Functions for Limit Switches	Wire Color	Wire Gauge (AWG)	Position Feedback		
				0. Without	1. Hall Sensor*1	2,N. Hall Sensor*2
A1	1. Two micro switches cut off the actuator at end of stroke	● GR	20	EXT+	EXT+	EXT+
		● YE	20	RET+	RET+	RET+
		● RE	26	-	Vcc	Vcc
		○ WH	26	-	S1	S1
		● BK	26	-	GND	GND
		● BU	26	-	-	S2
A1	2. Two micro switches cut off the actuator at end of stroke + third one in between sends signal	● GR	20	EXT+	EXT+	EXT+
		● YE	20	RET+	RET+	RET+
		● RE	26	-	-	-
		○ WH	26	COM	-	-
		● BK	26	MD LS (N.C.)	-	-
		● BU	26	-	-	-
A1	3. Two micro switches send signal at end of stroke	● GR	20	EXT+	EXT+	EXT+
		● YE	20	RET+	RET+	RET+
		● RE	26	COM	-	-
		○ WH	26	UP LS (N.C.)	-	-
		● BK	26	-	-	-
		● BU	26	LOW LS (N.C.)	-	-
A1	4. Two micro switches send signal at end of stroke + third one in between sends signal	● GR	20	EXT+	EXT+	EXT+
		● YE	20	RET+	RET+	RET+
		● RE	26	COM	-	-
		○ WH	26	UP LS (N.C.)	-	-
		● BK	26	MD LS (N.C.)	-	-
		● BU	26	LOW LS (N.C.)	-	-

Terms of Use

The user is responsible for determining the suitability of TiMOTION products for a specific application. TiMOTION products are subject to change without prior notice.