

TA2P

series

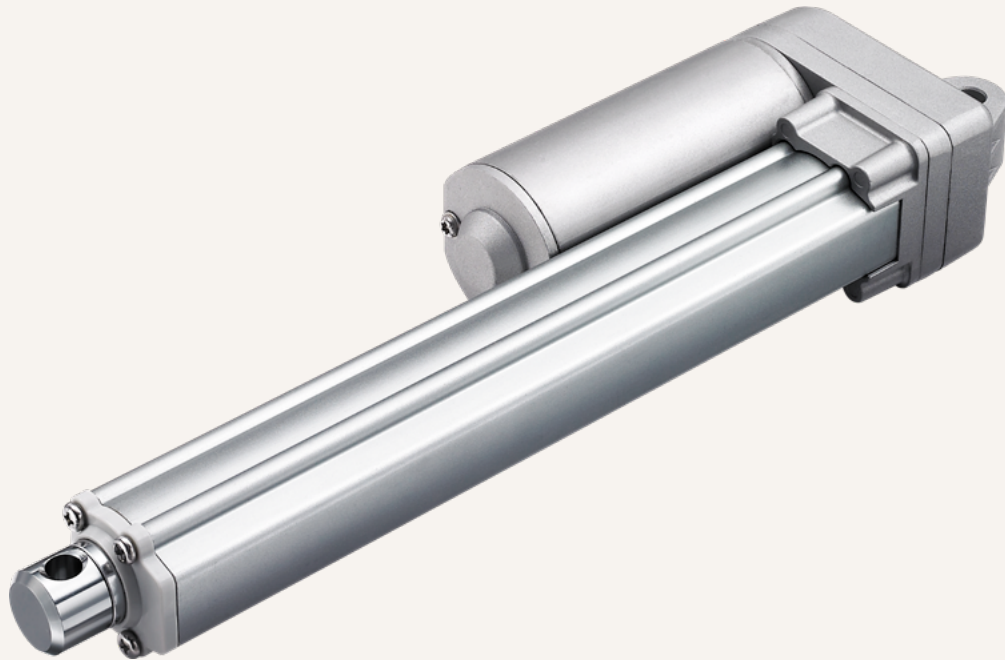

Product Segments

• Industrial Motion

Both the TA2 and the TA2P are compact, robust, and capable of performing well in certain outdoor environments. A more powerful motor makes the TA2P capable of handling load ratings up to 3500N (787 pounds) while retaining its compact size. In addition to the high power motor, the TA2P linear actuator is available with multiple choices for feedback sensors.

General Features

| | |
|---|--|
| Max. load | 3,500N (push); 2,000N (pull) |
| Max. speed at max. load | 2.4mm/s |
| Max. speed at no load | 56.5mm/s |
| Retracted length | ≥ Stroke + 108mm (with Hall sensors or without output signals) |
| IP rating | IP66M (dynamic) |
| Certificate | UL73 |
| Stroke | 20~1000mm |
| Output Signals | Mechanical pot., Hall sensor * 2 (5-36V input) |
| Voltage | 12/24/36/48V DC; 12/24/48V DC (PTC) |
| Color | Silver |
| Operational temperature range | -25°C ~ +65°C |
| Operational temperature range at full performance | +5°C ~ +45°C |

Drawing

Dimensions
without Output Signal
or with Hall Sensors
(mm)

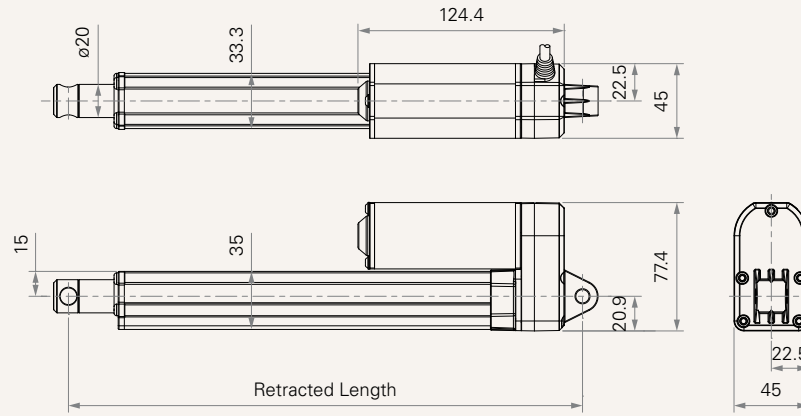

Dimensions
with POT
or Reed Sensor
(mm)

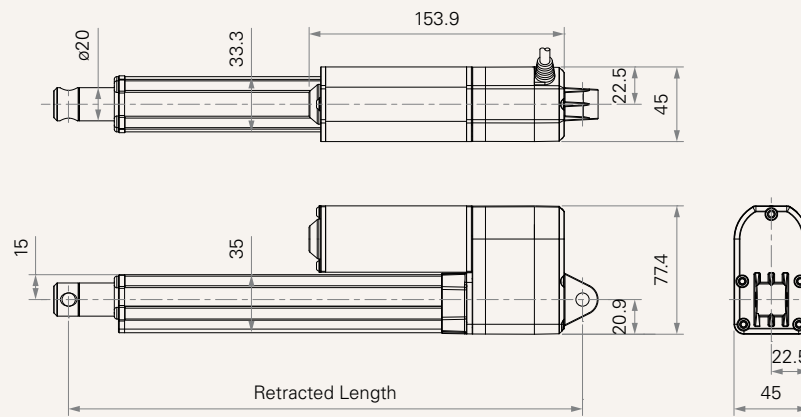

Load and Speed (12V DC)

| CODE | Load (N) | | Self Locking Force (N) | Typical Current (A) | | Typical Speed (mm/s) | |
|--|----------|------|------------------------|---------------------|-----------|----------------------|-----------|
| | Push | Pull | | No Load | With Load | No Load | With Load |
| Motor Speed (5200RPM, Duty Cycle 25%) | | | | | | | |
| A | 250 | 250 | 250 | 2.3 | 4.3 | 41.0 | 38.0 |
| B | 500 | 500 | 500 | 2.2 | 4.7 | 29.0 | 26.0 |
| C | 1000 | 1000 | 1000 | 2.2 | 5.0 | 14.0 | 13.5 |
| D | 1500 | 1500 | 1500 | 2.0 | 5.1 | 9.0 | 8.0 |
| E | 2000 | 2000 | 2000 | 2.0 | 5.1 | 7.1 | 6.0 |
| Motor Speed (6600RPM, Duty Cycle 25%) | | | | | | | |
| F | 250 | 250 | 250 | 2.8 | 4.9 | 55.5 | 44.2 |
| G | 500 | 500 | 500 | 2.7 | 5.2 | 31.6 | 26.5 |
| H | 1000 | 1000 | 1000 | 2.6 | 5.5 | 16.5 | 14.0 |
| K | 1500 | 1500 | 1500 | 2.6 | 5.5 | 11.1 | 9.5 |
| L | 2000 | 2000 | 2000 | 2.6 | 5.5 | 9.0 | 7.5 |
| Motor Speed (3800RPM, Duty Cycle 25%) | | | | | | | |
| S | 3500 | 2000 | 3500 | 1.6 | 4.8 | 3.2 | 2.4 |
| Motor Speed (2200RPM, Duty Cycle 25%) | | | | | | | |
| T | 2000 | 2000 | 2000 | 0.6 | 1.2 | 3.2 | 2.3 |

Load and Speed (24V DC)

| CODE | Load (N) | | Self Locking Force (N) | Typical Current (A) | | Typical Speed (mm/s) | |
|--|----------|------|------------------------|---------------------|-----------|----------------------|-----------|
| | Push | Pull | | No Load | With Load | No Load | With Load |
| Motor Speed (5200RPM, Duty Cycle 25%) | | | | | | | |
| A | 250 | 250 | 250 | 1.2 | 2.0 | 43.0 | 36.0 |
| B | 500 | 500 | 500 | 1.1 | 2.2 | 25.8 | 23.0 |
| C | 1000 | 1000 | 1000 | 1.1 | 2.4 | 14.0 | 11.8 |
| D | 1500 | 1500 | 1500 | 1.0 | 2.5 | 9.0 | 8.0 |
| E | 2000 | 2000 | 2000 | 1.0 | 2.3 | 7.1 | 6.2 |
| Motor Speed (6600RPM, Duty Cycle 25%) | | | | | | | |
| F | 250 | 250 | 250 | 1.6 | 2.7 | 56.5 | 45.0 |
| G | 500 | 500 | 500 | 1.5 | 2.9 | 32.5 | 28.5 |
| H | 1000 | 1000 | 1000 | 1.5 | 2.9 | 16.5 | 14.3 |
| K | 1500 | 1500 | 1500 | 1.3 | 2.9 | 11.1 | 10.0 |
| L | 2000 | 2000 | 2000 | 1.3 | 2.9 | 8.8 | 7.7 |
| Motor Speed (3800RPM, Duty Cycle 25%) | | | | | | | |
| S | 3500 | 2000 | 3500 | 0.8 | 2.5 | 3.2 | 2.4 |
| Motor Speed (2200RPM, Duty Cycle 25%) | | | | | | | |
| T | 2000 | 2000 | 2000 | 0.3 | 0.9 | 3.2 | 2.3 |

Load and Speed (36V DC)

| CODE | Load (N) | | Self Locking Force (N) | Typical Current (A) | | Typical Speed (mm/s) | |
|--|----------|------|------------------------|---------------------|-----------|----------------------|-----------|
| | Push | Pull | | No Load | With Load | No Load | With Load |
| Motor Speed (5200RPM, Duty Cycle 25%) | | | | | | | |
| A | 250 | 250 | 250 | 0.8 | 1.4 | 43.0 | 36.0 |
| B | 500 | 500 | 500 | 0.8 | 1.5 | 25.8 | 23.0 |
| C | 1000 | 1000 | 1000 | 0.8 | 1.6 | 14.0 | 11.8 |
| D | 1500 | 1500 | 1500 | 0.7 | 1.7 | 9.0 | 8.0 |
| E | 2000 | 2000 | 2000 | 0.7 | 1.6 | 7.1 | 6.2 |
| Motor Speed (6600RPM, Duty Cycle 25%) | | | | | | | |
| F | 250 | 250 | 250 | 1.1 | 1.8 | 56.5 | 45.0 |
| G | 500 | 500 | 500 | 1.0 | 2.0 | 32.5 | 28.5 |
| H | 1000 | 1000 | 1000 | 1.0 | 2.0 | 16.5 | 14.3 |
| K | 1500 | 1500 | 1500 | 0.9 | 2.0 | 11.1 | 10.0 |
| L | 2000 | 2000 | 2000 | 0.9 | 2.0 | 8.8 | 7.7 |
| Motor Speed (3800RPM, Duty Cycle 25%) | | | | | | | |
| S | 3500 | 2000 | 3500 | 0.6 | 1.7 | 3.2 | 2.4 |
| Motor Speed (2200RPM, Duty Cycle 25%) | | | | | | | |
| T | 2000 | 2000 | 2000 | 0.2 | 0.6 | 3.2 | 2.3 |

Load and Speed (48V DC)

| CODE | Load (N) | | Self Locking Force (N) | Typical Current (A) | | Typical Speed (mm/s) | |
|--|----------|------|------------------------|---------------------|-----------|----------------------|-----------|
| | Push | Pull | | No Load | With Load | No Load | With Load |
| Motor Speed (5200RPM, Duty Cycle 25%) | | | | | | | |
| A | 250 | 250 | 250 | 0.6 | 1.0 | 43.0 | 36.0 |
| B | 500 | 500 | 500 | 0.6 | 1.1 | 25.8 | 23.0 |
| C | 1000 | 1000 | 1000 | 0.6 | 1.2 | 14.0 | 11.8 |
| D | 1500 | 1500 | 1500 | 0.5 | 1.3 | 9.0 | 8.0 |
| E | 2000 | 2000 | 2000 | 0.5 | 1.2 | 7.1 | 6.2 |
| Motor Speed (6600RPM, Duty Cycle 25%) | | | | | | | |
| F | 250 | 250 | 250 | 0.8 | 1.4 | 56.5 | 45.0 |
| G | 500 | 500 | 500 | 0.8 | 1.5 | 32.5 | 28.5 |
| H | 1000 | 1000 | 1000 | 0.8 | 1.5 | 16.5 | 14.3 |
| K | 1500 | 1500 | 1500 | 0.7 | 1.5 | 11.1 | 10.0 |
| L | 2000 | 2000 | 2000 | 0.7 | 1.5 | 8.8 | 7.7 |
| Motor Speed (3800RPM, Duty Cycle 25%) | | | | | | | |
| S | 3500 | 2000 | 3500 | 0.4 | 1.3 | 3.2 | 2.4 |
| Motor Speed (2200RPM, Duty Cycle 25%) | | | | | | | |
| T | 2000 | 2000 | 2000 | 0.2 | 0.5 | 3.2 | 2.3 |

Note

- 1 Please refer to the approved drawing for the final authentic value.
- 2 This self-locking force level is reached only when a short circuit is applied on the terminals of the motor. All the TiMOTION control boxes have this feature built-in.
- 3 Voltage range: 24V±10%, 12V±20%, 36V±10%, 48V±10%.
- 4 The current & speed in table are tested when the actuator is extending under push load.
- 5 The current & speed in table and diagram are tested with a stable 24V DC power supply.
- 6 Without load, noise level ≤ 71~83dBA (by TiMOTION test standard, ambient noise level ≤ 36dBA).
- 7 Standard stroke restriction: Min. ≥ 20mm, Max. please refer to the table below. When choosing "Two micro switches cut off the actuator at EOS", A, B, F, G, H options, reserve space for equipotential braking is needed, the minimum value is ≥ 40mm, if minimum stroke < 40mm, a customized thrust bearing is required.
- 8 Tolerance: fully extended length & retracted length ±2mm.

| CODE | Load (N) | Min. Stroke (mm) | | Max. Stroke (mm) |
|----------------|----------|----------------------------|--------|------------------|
| | | Function of Limit Switches | | |
| | | #1, #2 | #3, #4 | |
| A, F | ≤ 250 | 40 | 20 | 1000 |
| B, G | ≤ 750 | 40 | 20 | 800 |
| H | ≤ 1000 | 40 | 20 | 600 |
| C | ≤ 1000 | 20 | 20 | 600 |
| D, K | ≤ 1500 | 20 | 20 | 500 |
| E, L, T | ≤ 2000 | 20 | 20 | 450 |
| S | ≤ 3500 | 20 | 20 | 300 |

Performance Data (12V DC)

Motor Speed (5200RPM)

Speed vs. Load

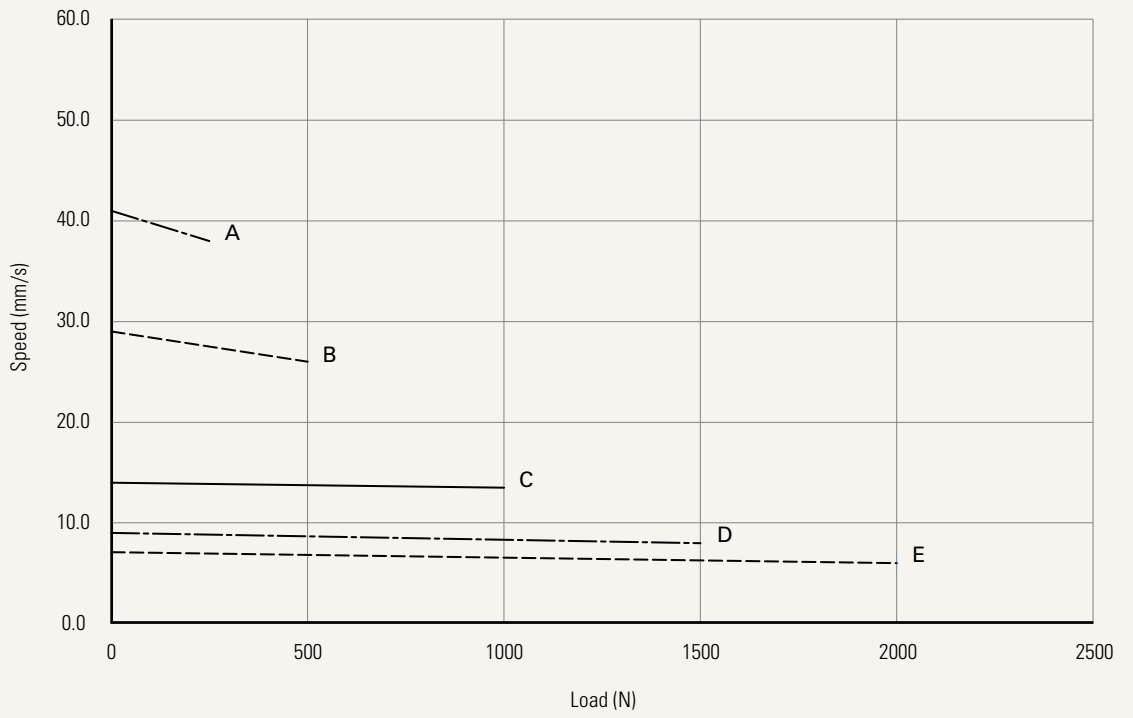

Current vs. Load

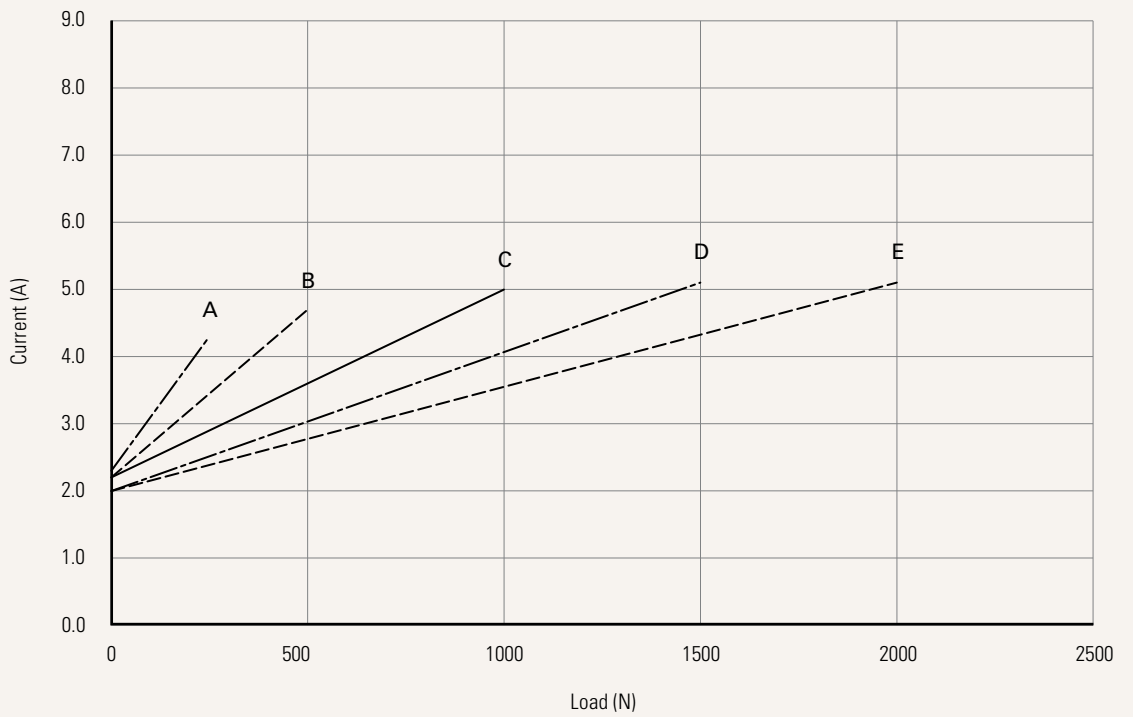

Performance Data (12V DC)

Motor Speed (6600RPM)

Speed vs. Load

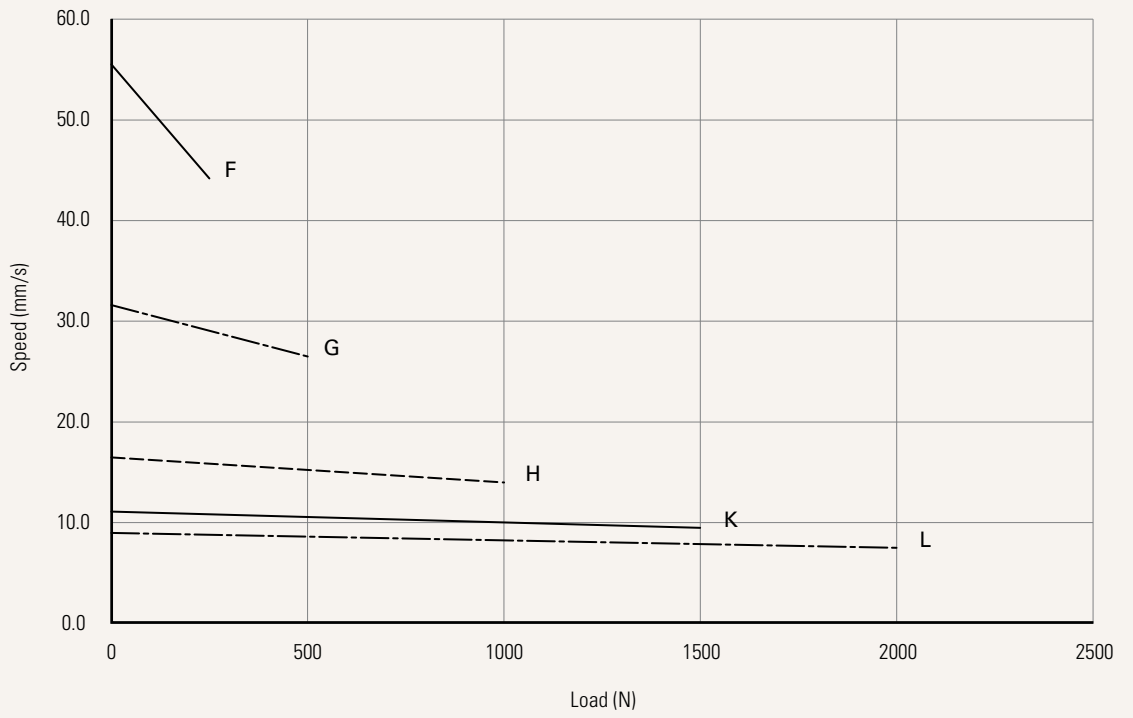

Current vs. Load

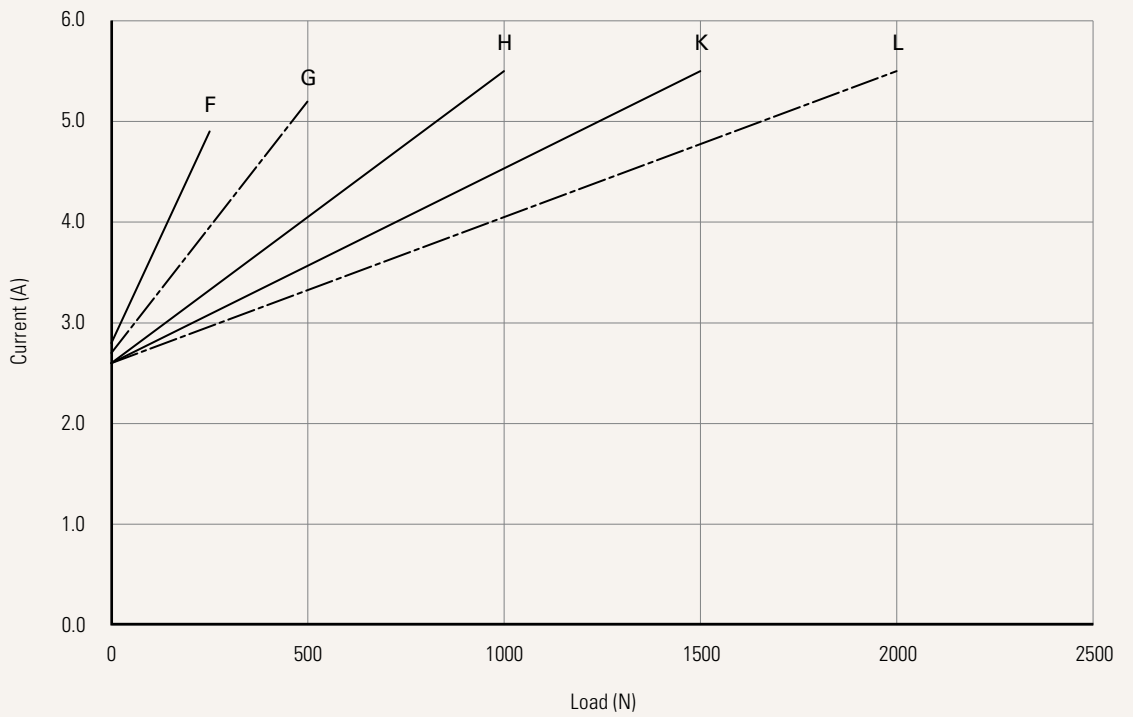

Performance Data (12V DC)

Motor Speed (3800RPM)

Speed vs. Load

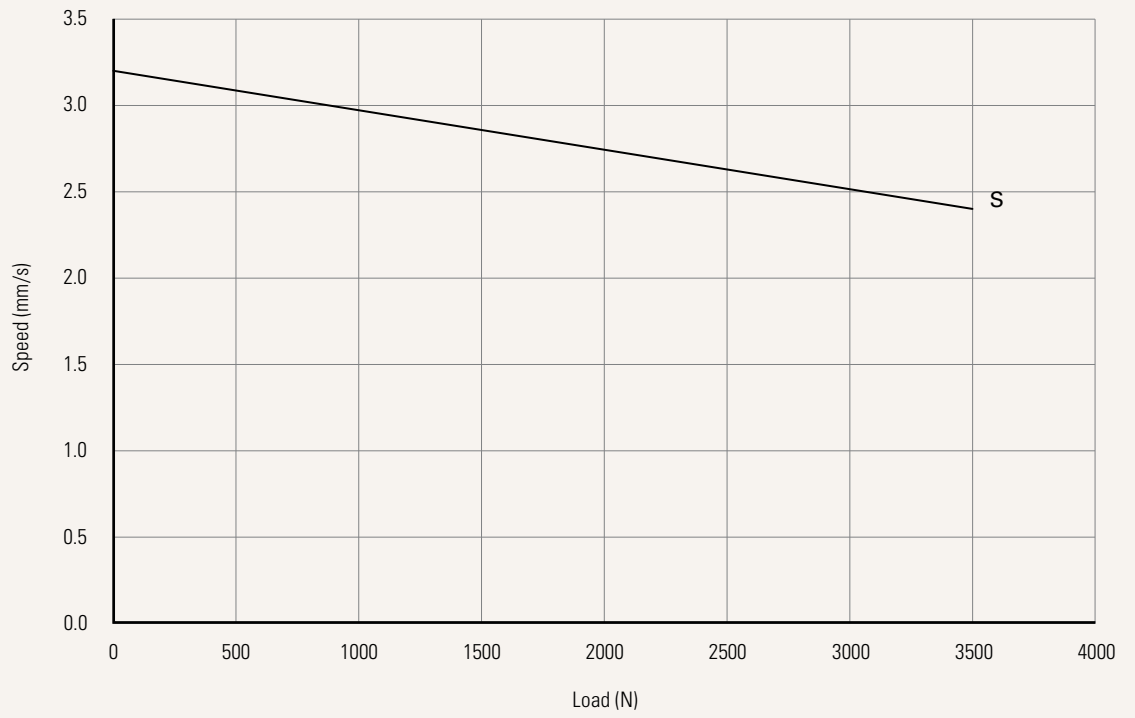

Current vs. Load

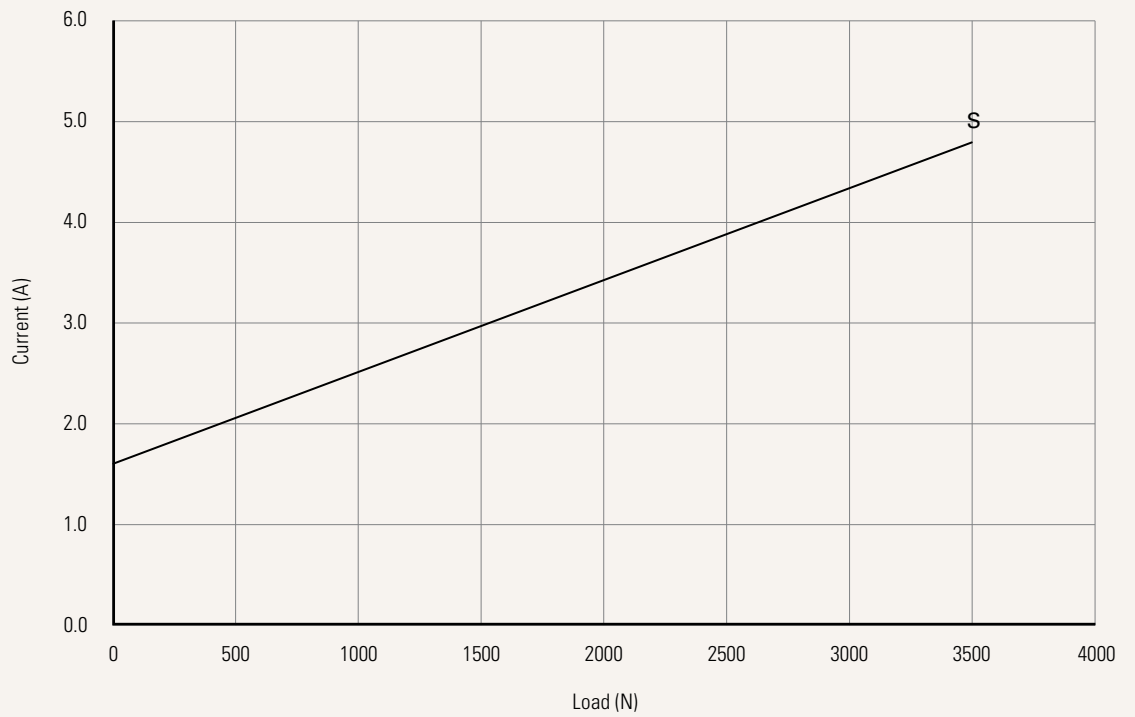

Performance Data (12V DC)

Motor Speed (2200RPM)

Speed vs. Load

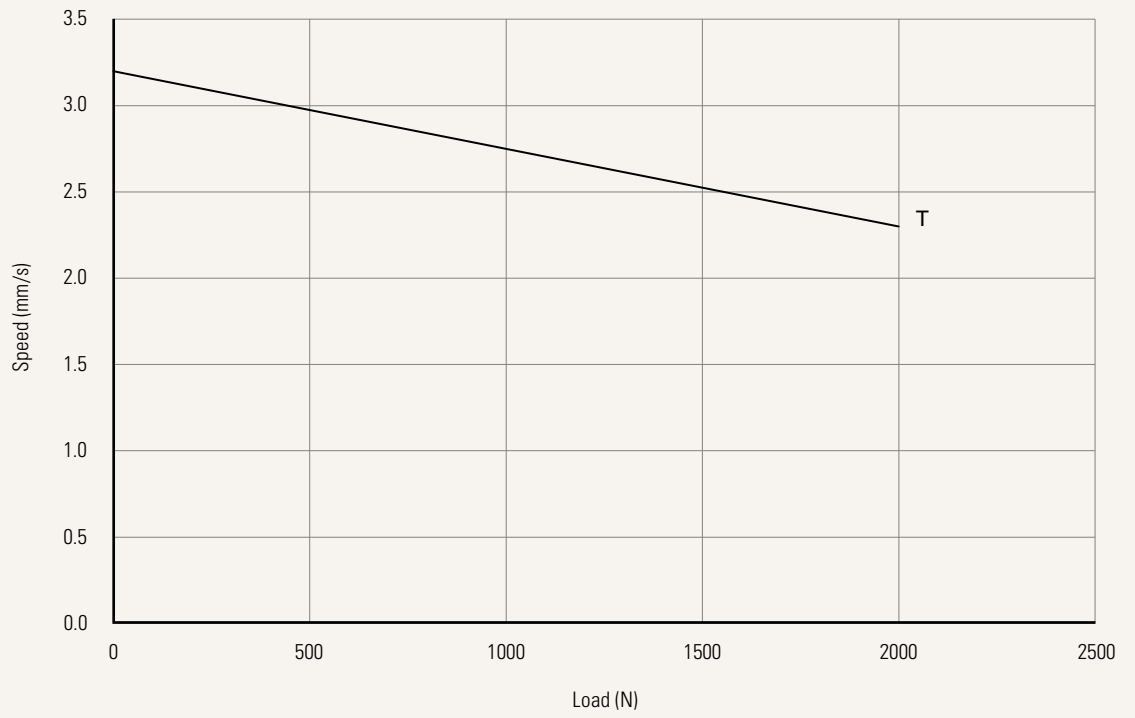

Current vs. Load

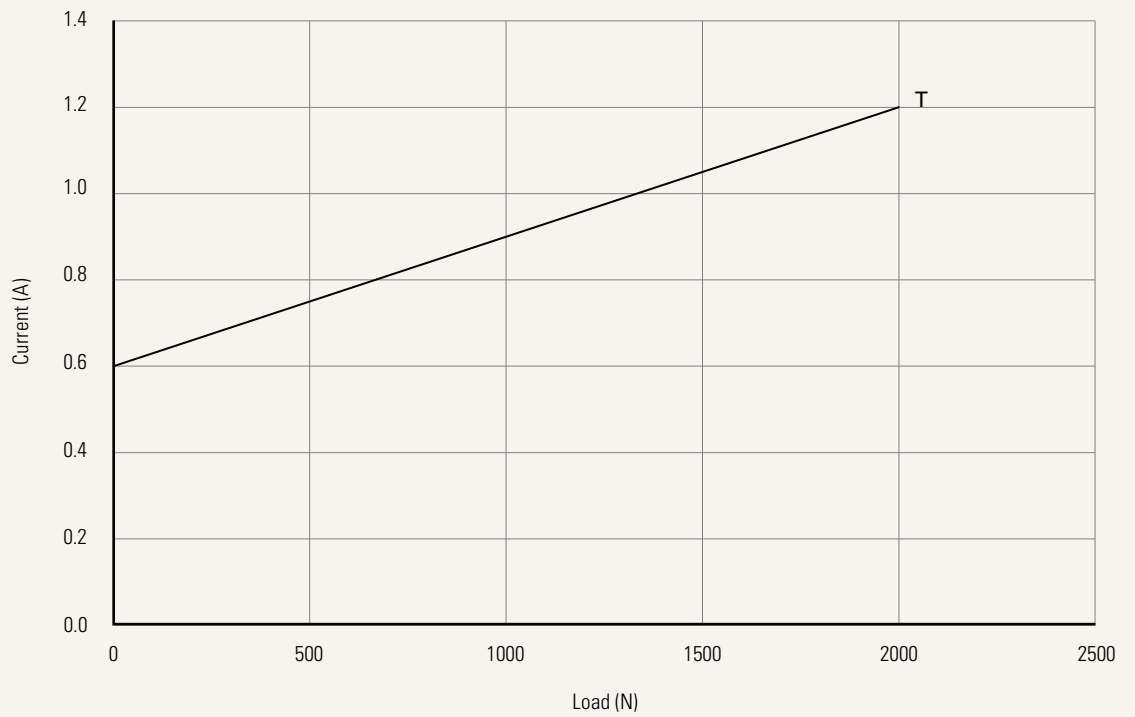

Performance Data (24V DC)

Motor Speed (5200RPM)

Speed vs. Load

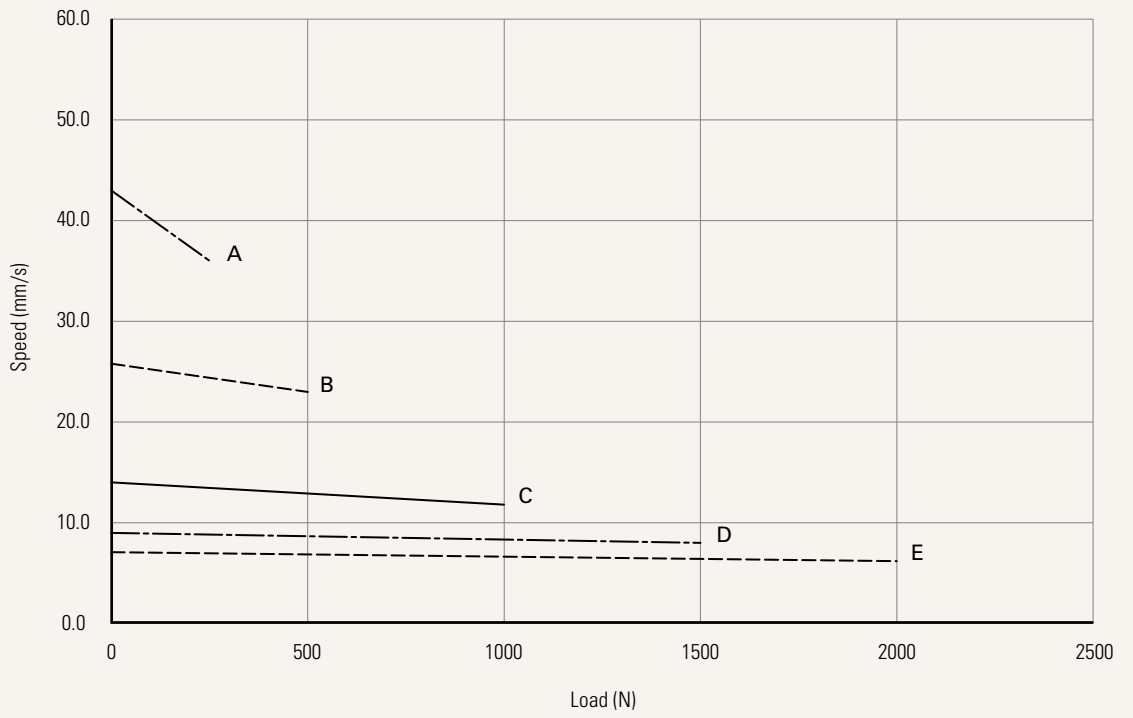

Current vs. Load

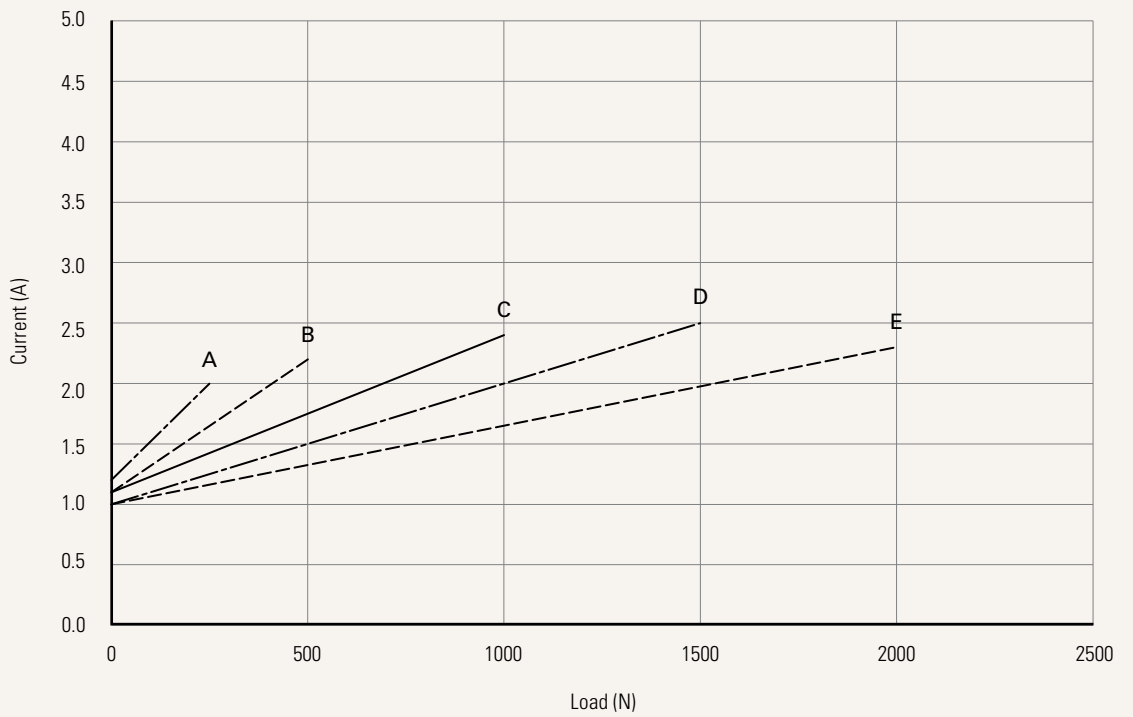

Performance Data (24V DC)

Motor Speed (6600RPM)

Speed vs. Load

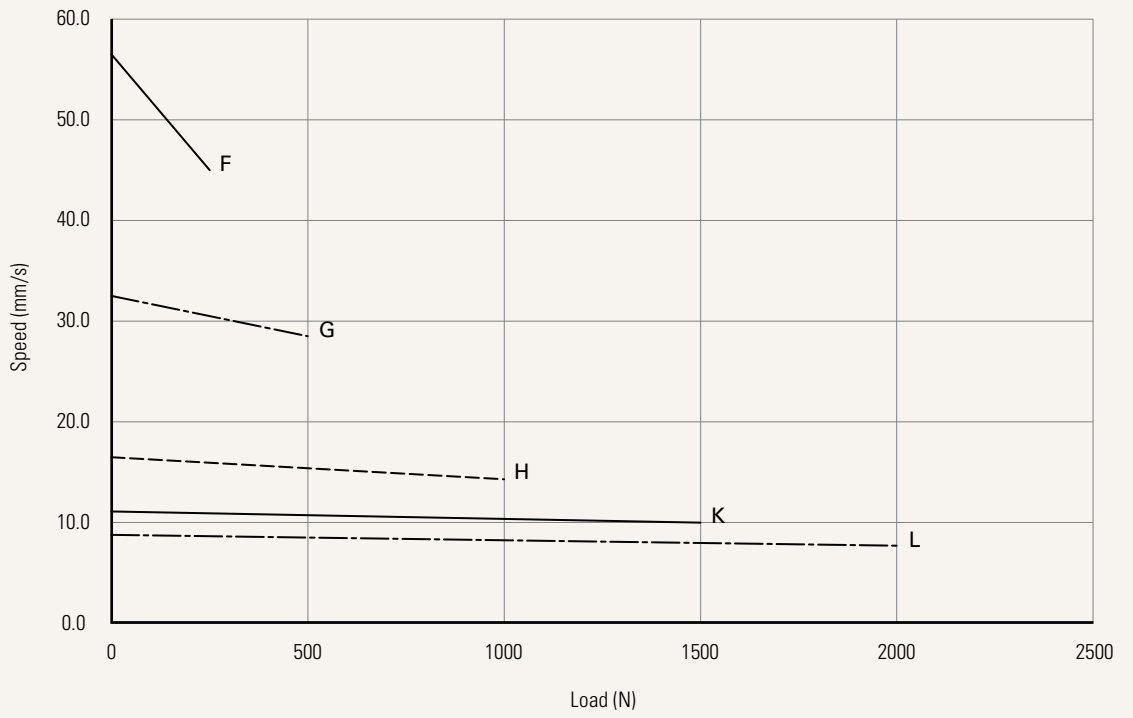

Current vs. Load

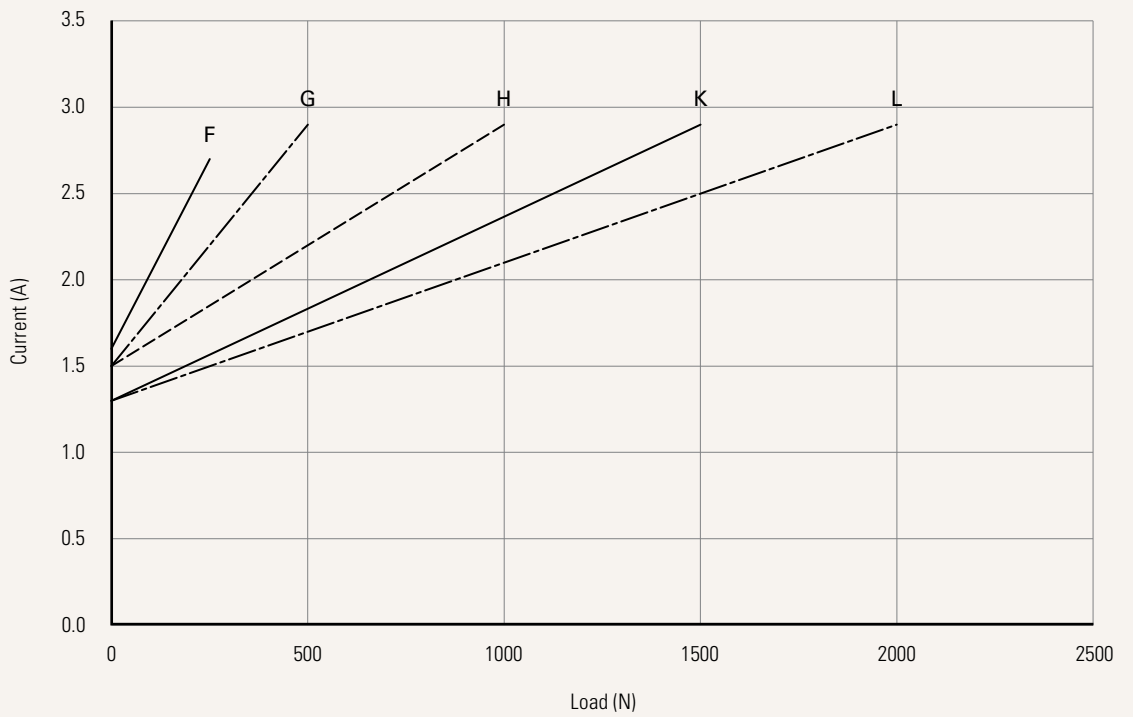

Performance Data (24V DC)

Motor Speed (3800RPM)

Speed vs. Load

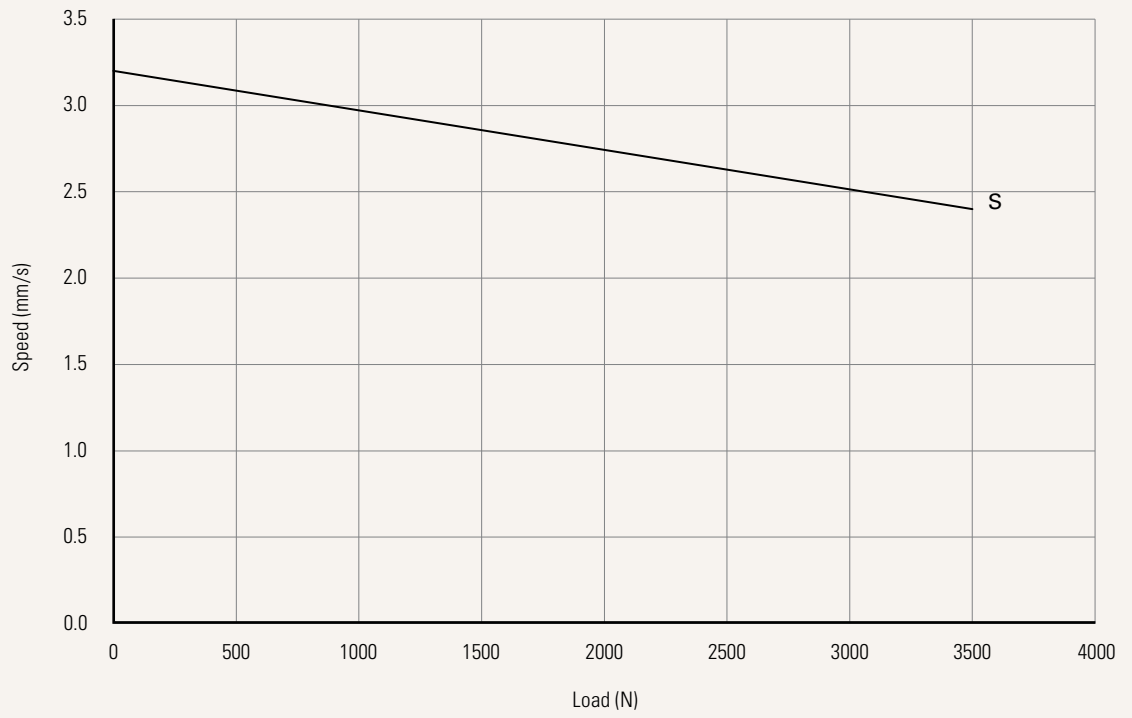

Current vs. Load



Performance Data (24V DC)

Motor Speed (2200RPM)

Speed vs. Load

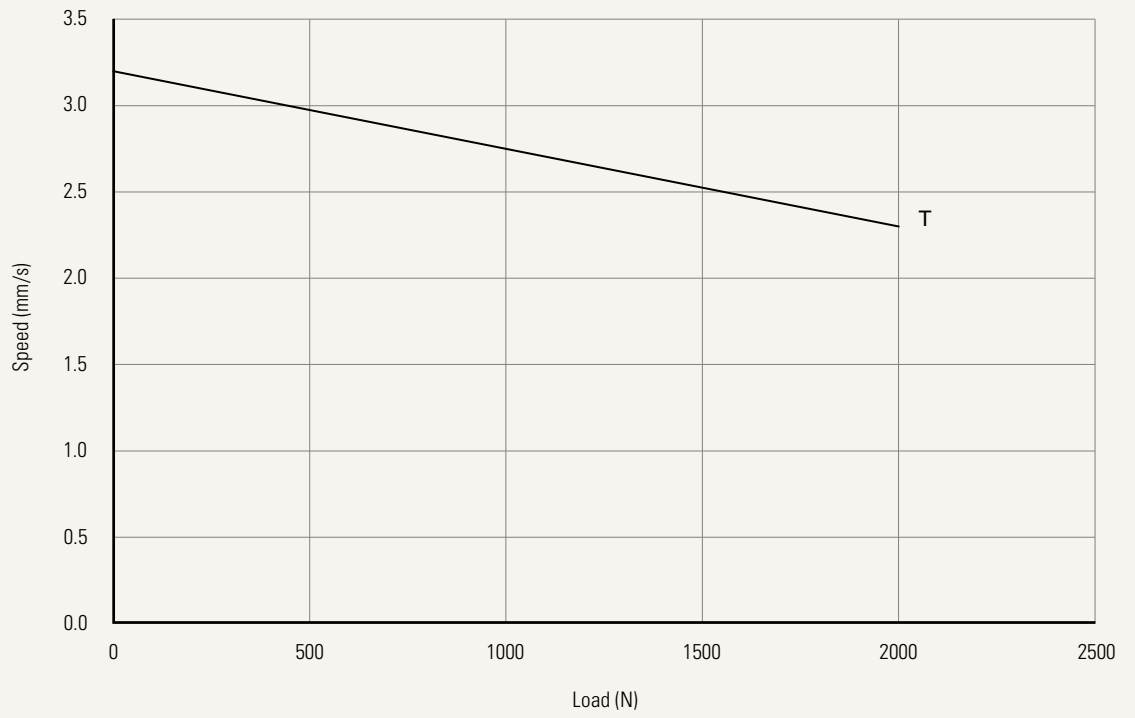

Current vs. Load

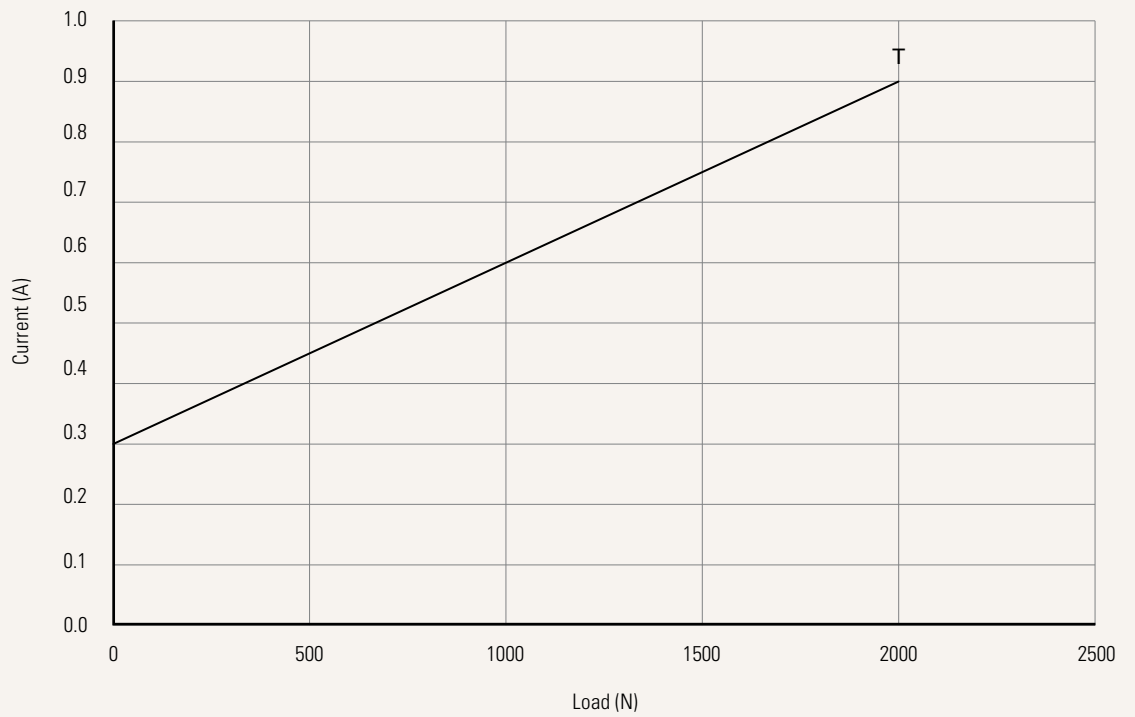

Performance Data (36V DC)

Motor Speed (5200RPM)

Speed vs. Load

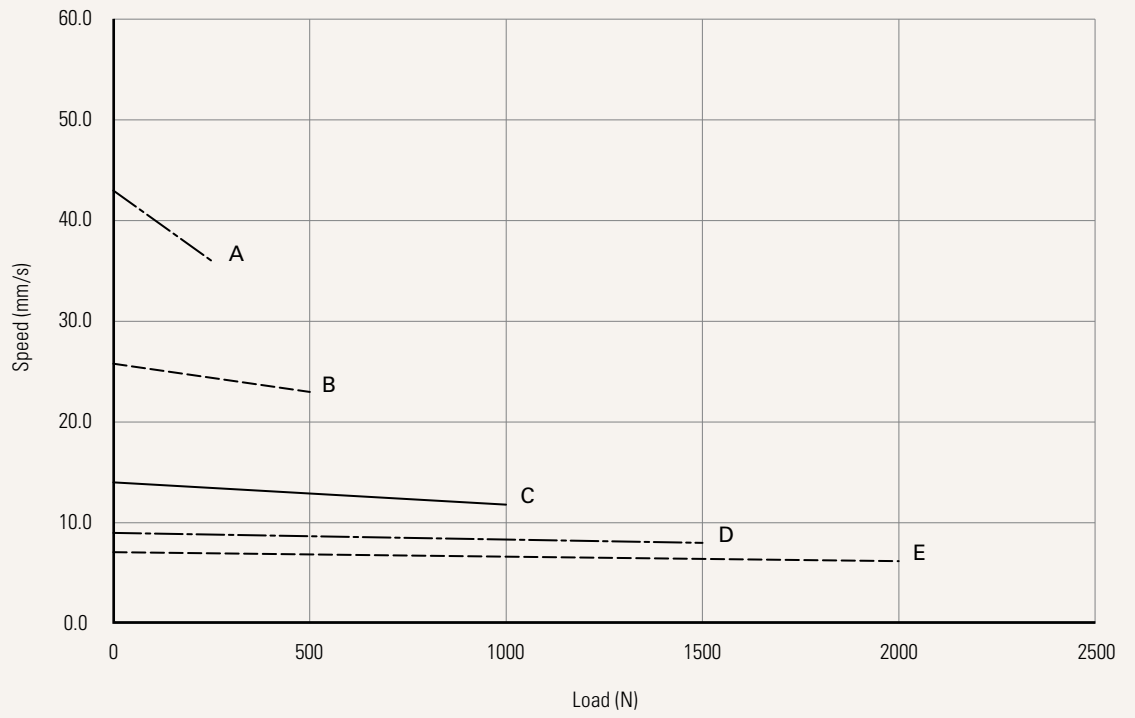

Current vs. Load

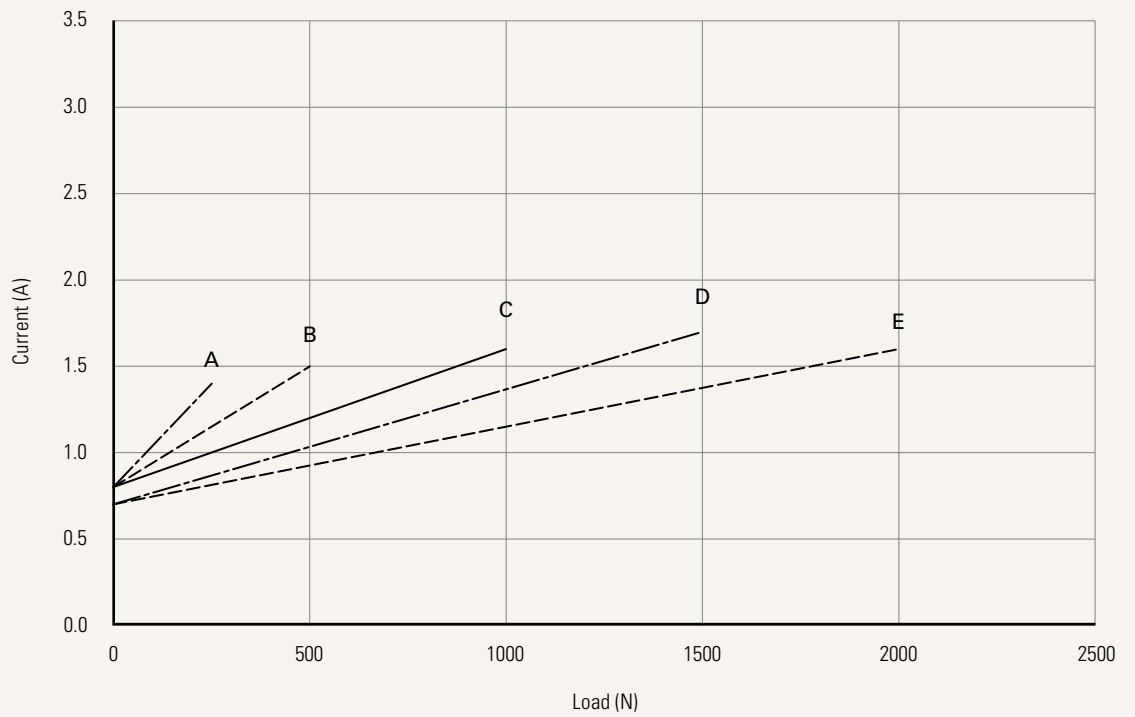

Performance Data (36V DC)

Motor Speed (6600RPM)

Speed vs. Load

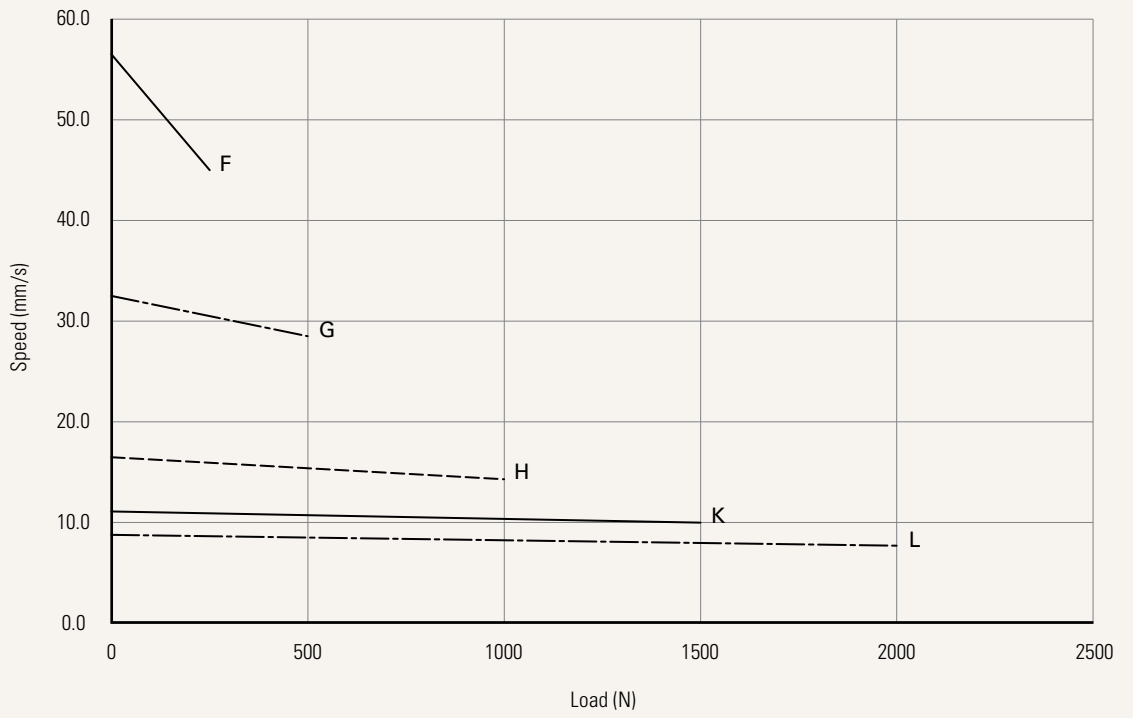

Current vs. Load

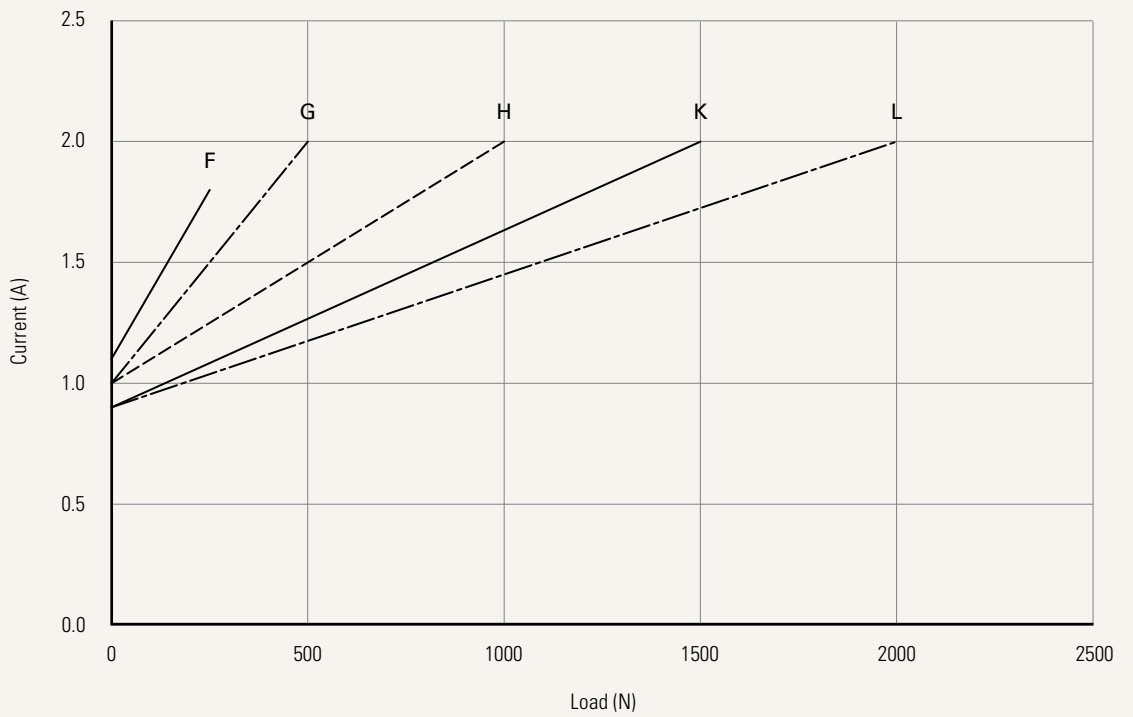

Performance Data (36V DC)

Motor Speed (3800RPM)

Speed vs. Load

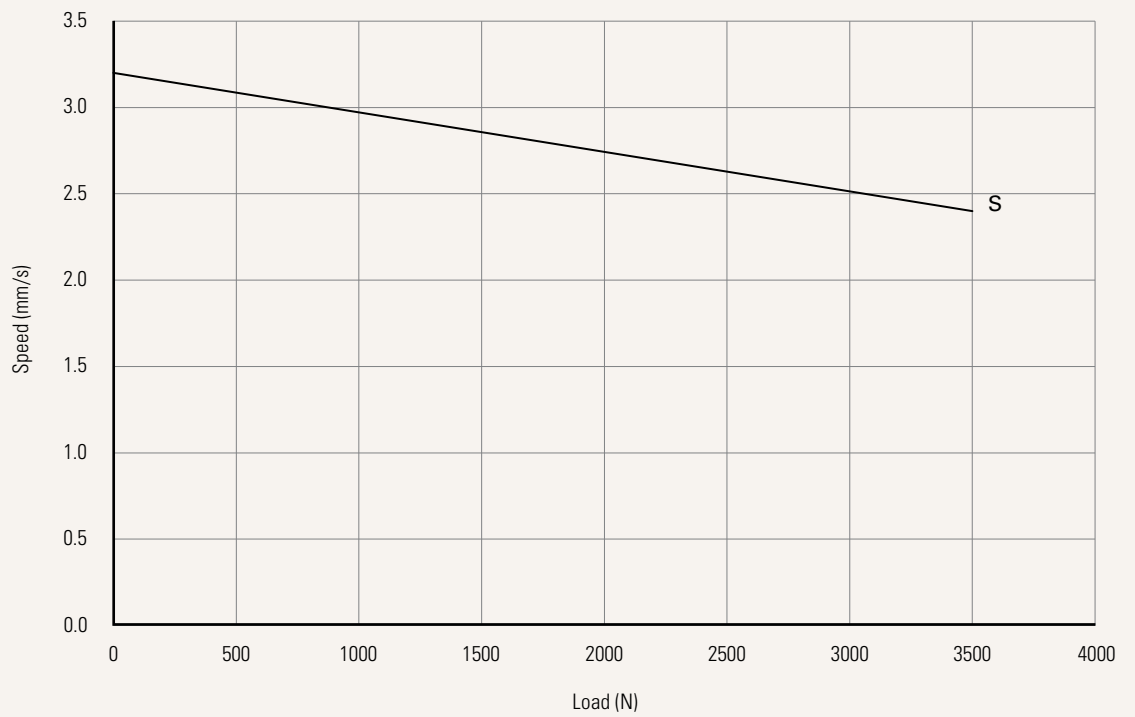

Current vs. Load

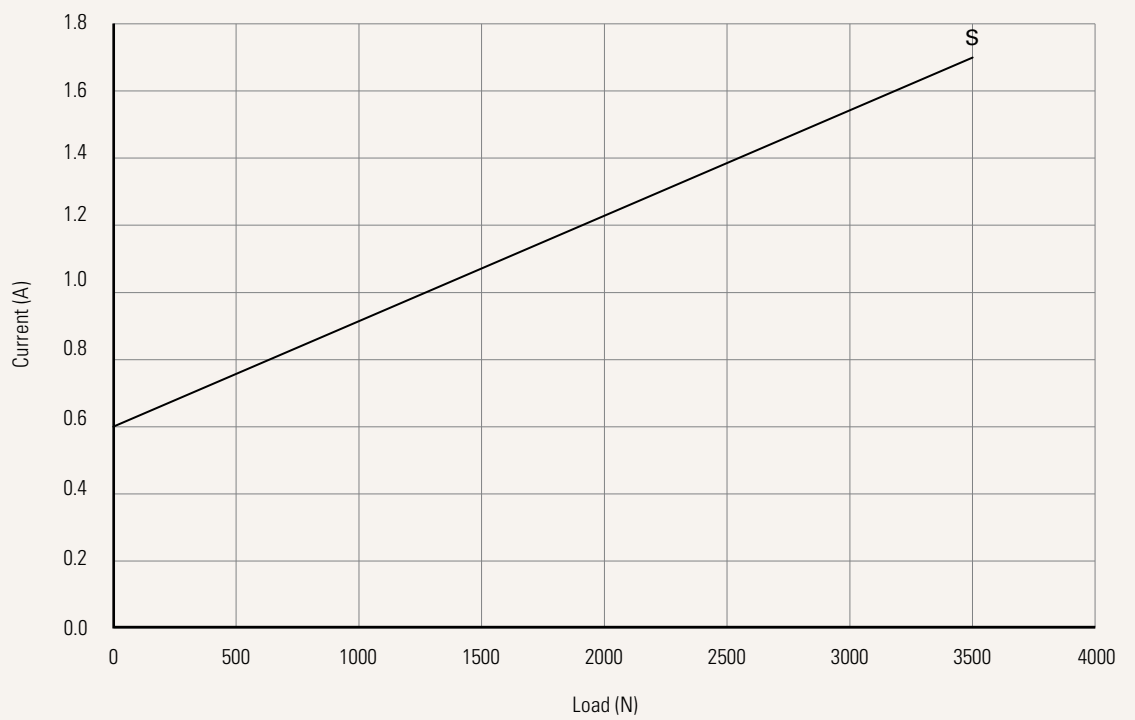

Performance Data (36V DC)

Motor Speed (2200RPM)

Speed vs. Load

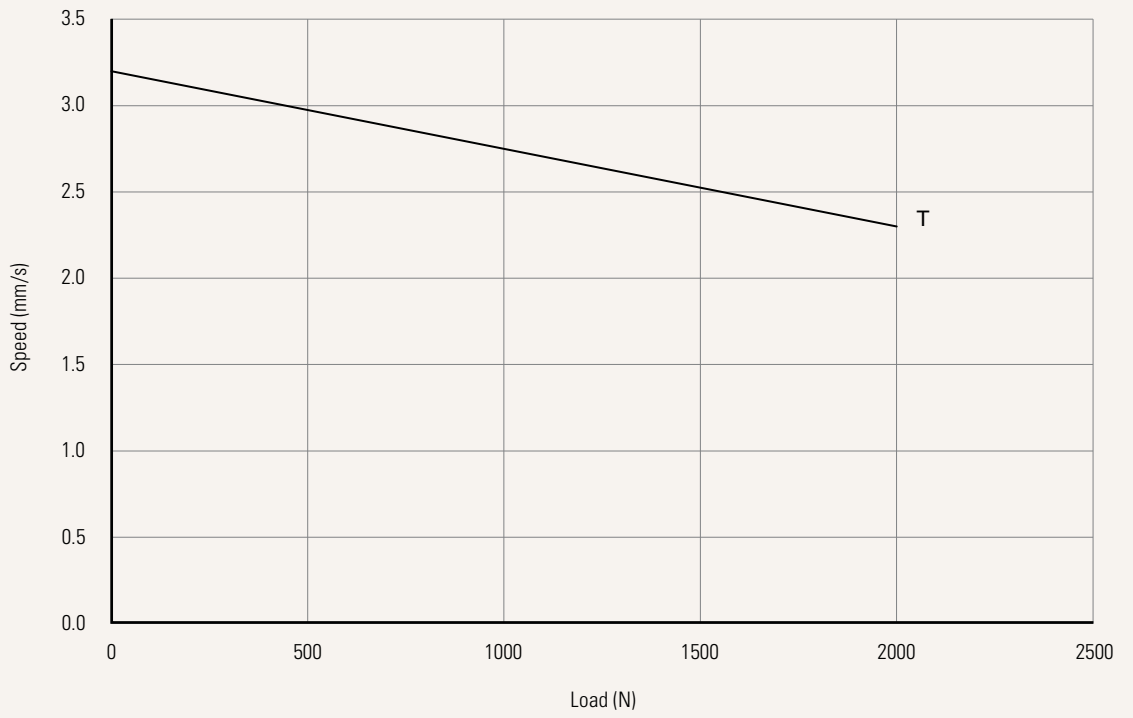

Current vs. Load

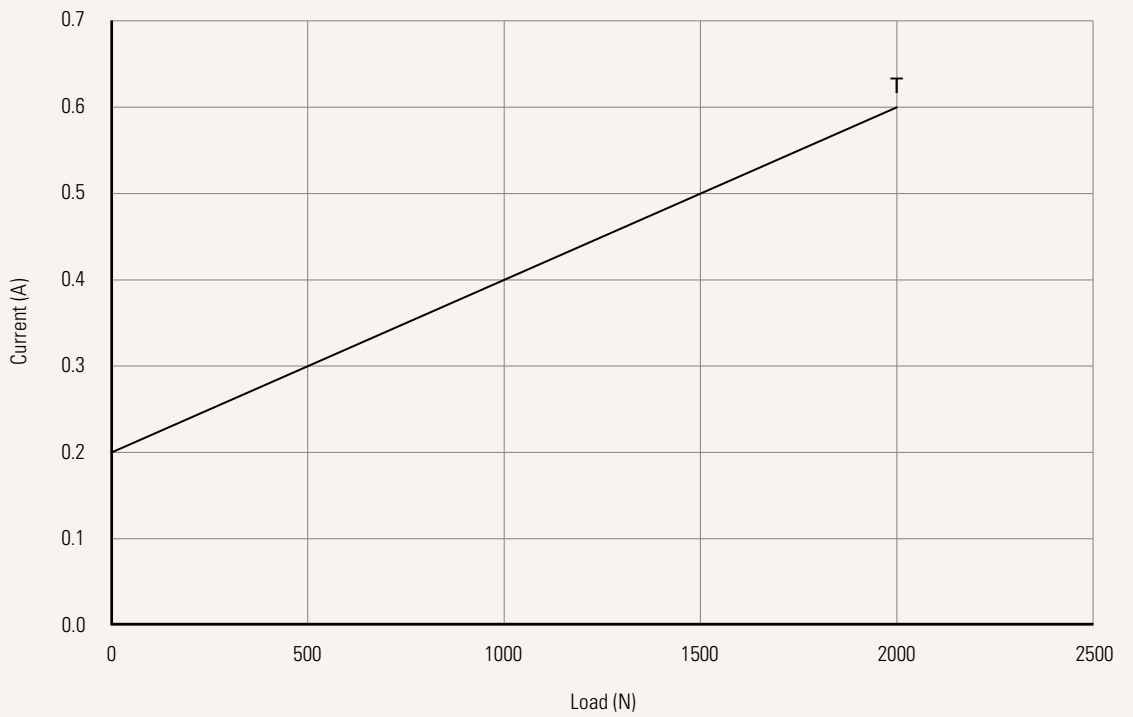

Performance Data (48V DC)

Motor Speed (5200RPM)

Speed vs. Load

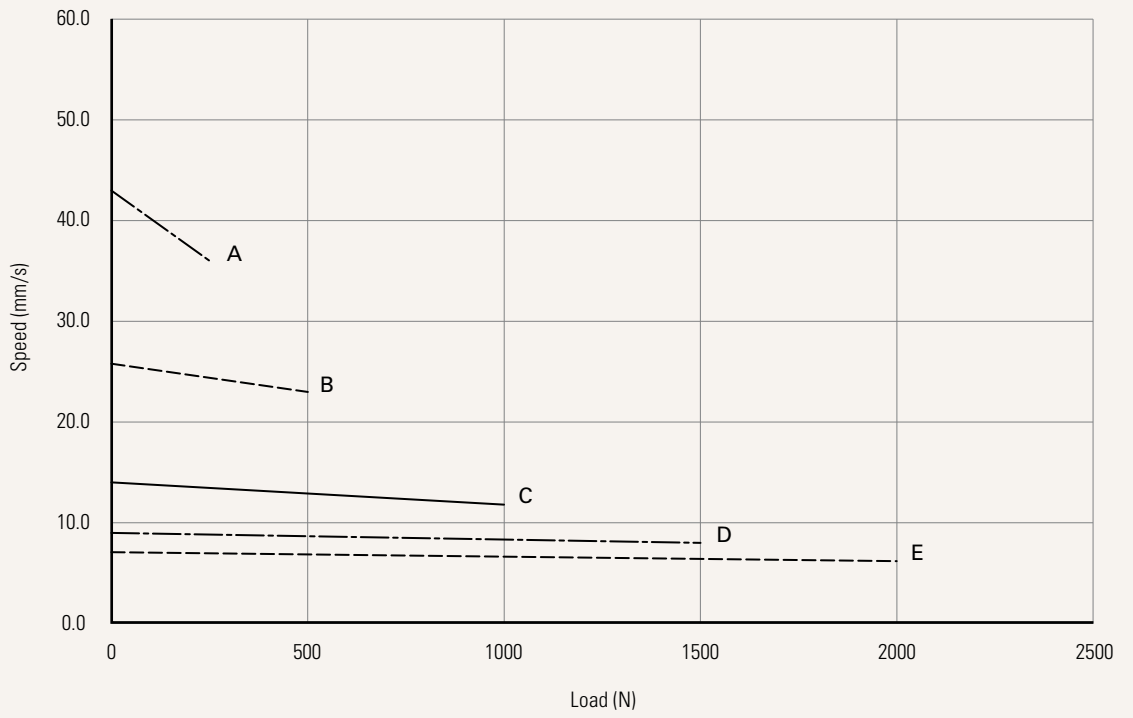

Current vs. Load

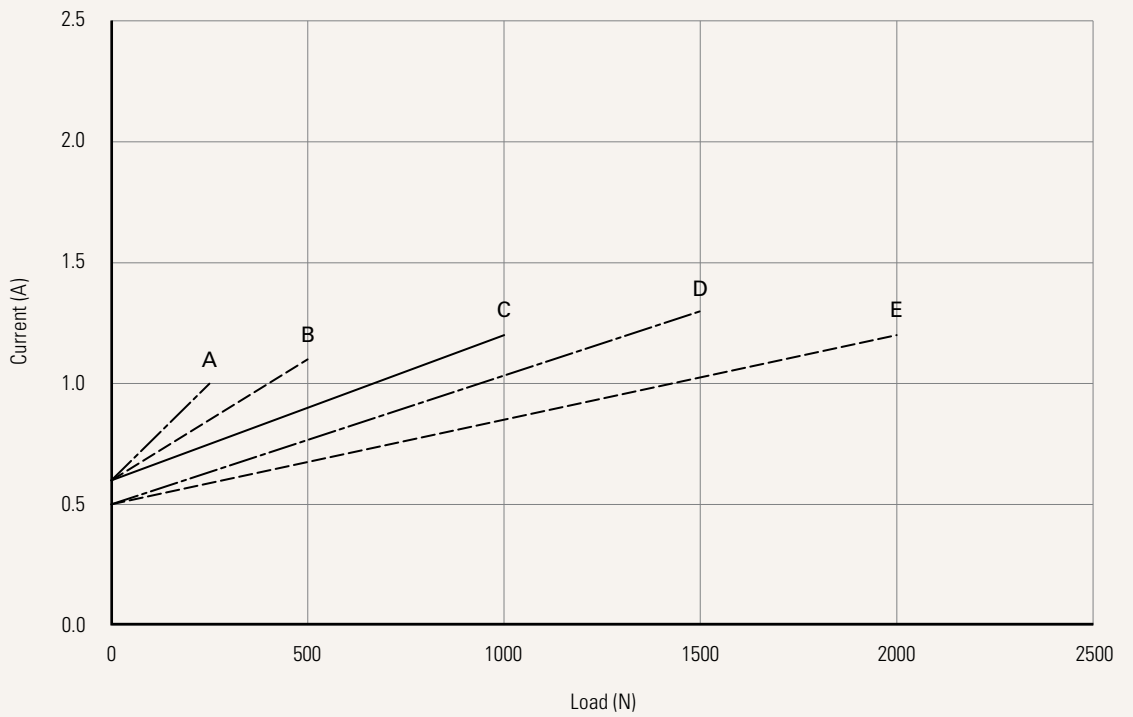

Performance Data (48V DC)

Motor Speed (6600RPM)

Speed vs. Load

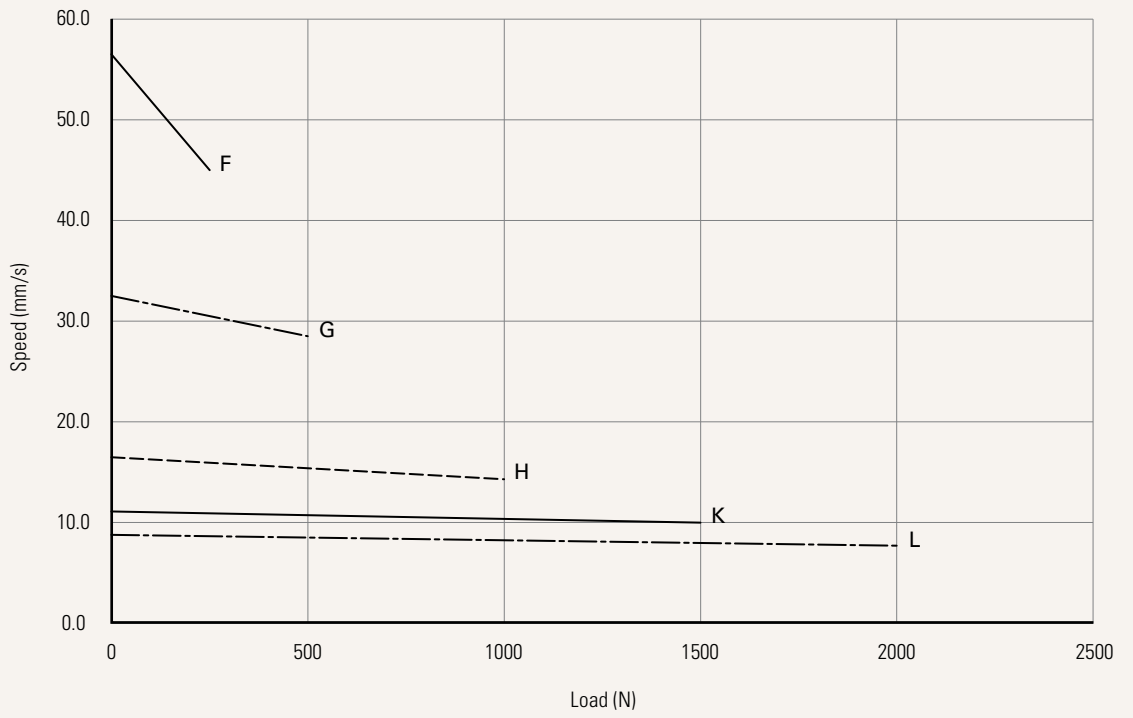

Current vs. Load

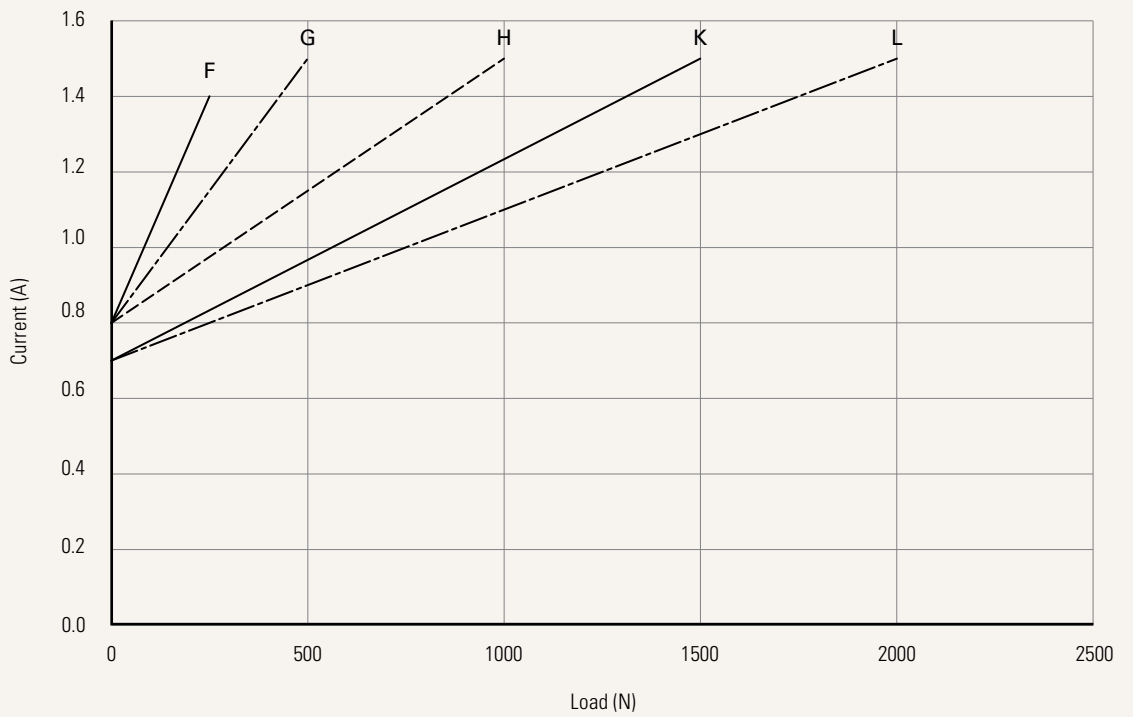

Performance Data (48V DC)

Motor Speed (3800RPM)

Speed vs. Load

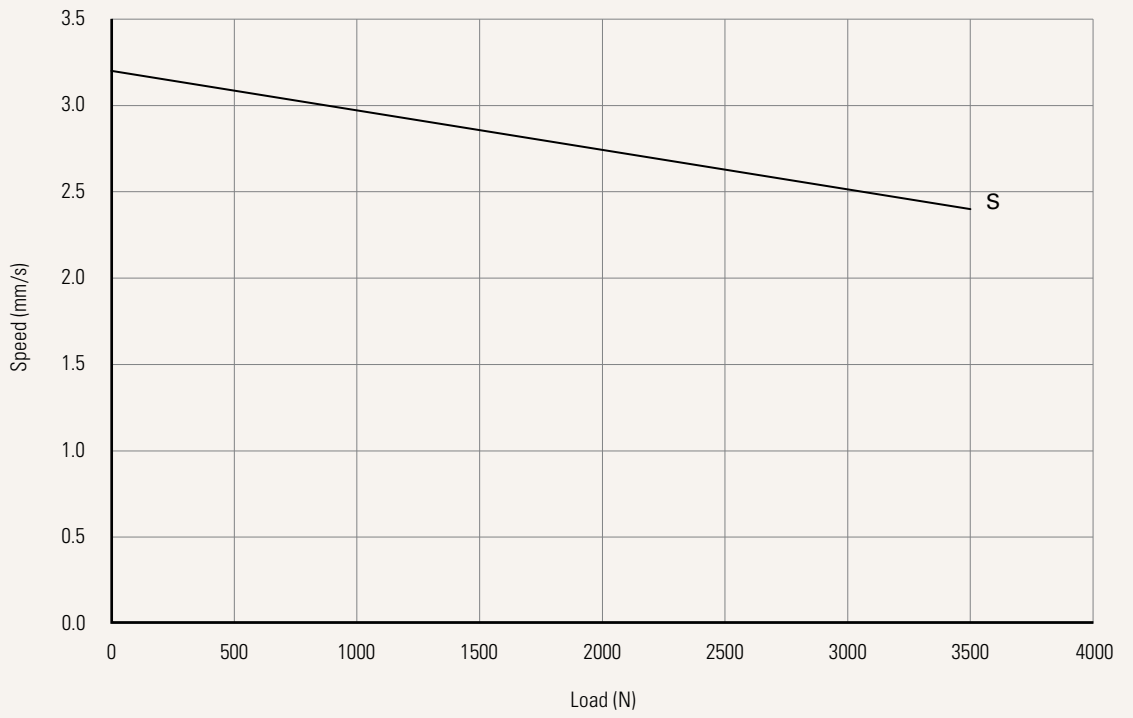

Current vs. Load

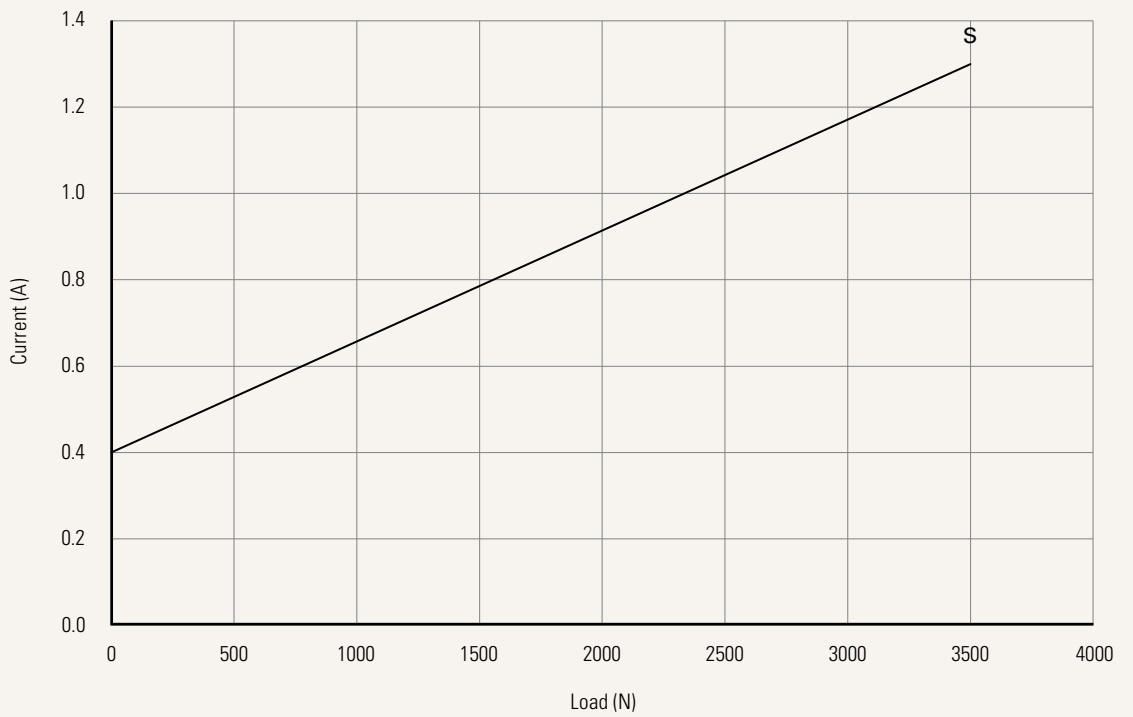

Performance Data (48V DC)

Motor Speed (2200RPM)

Speed vs. Load

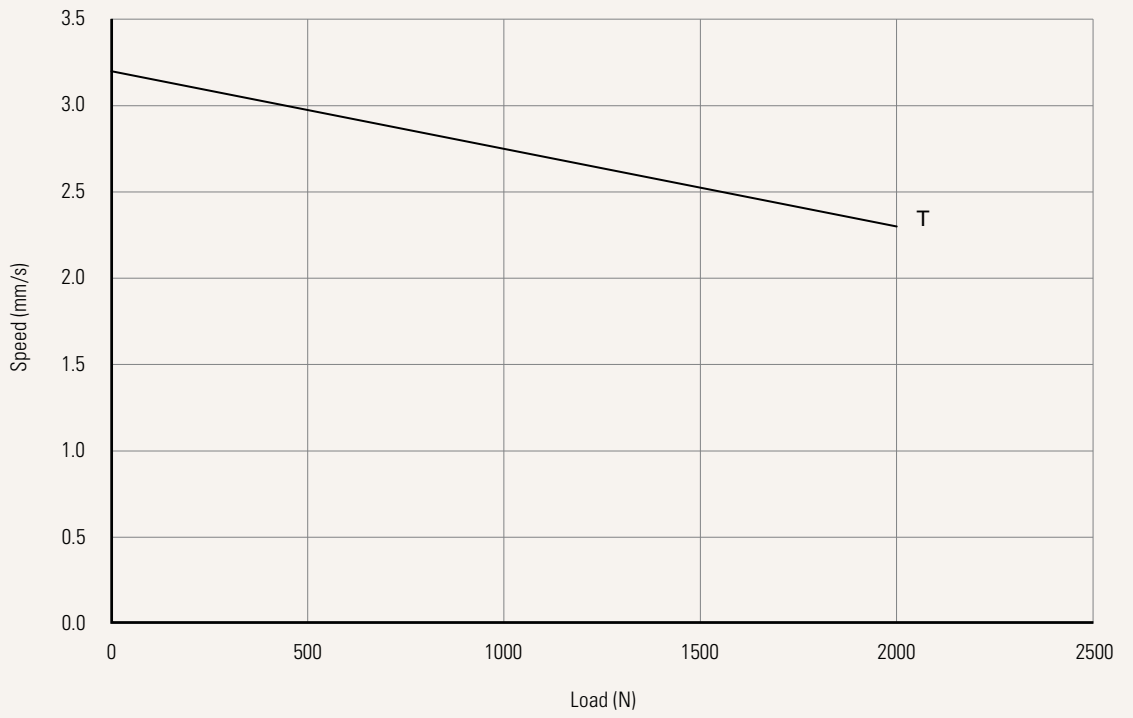

Current vs. Load

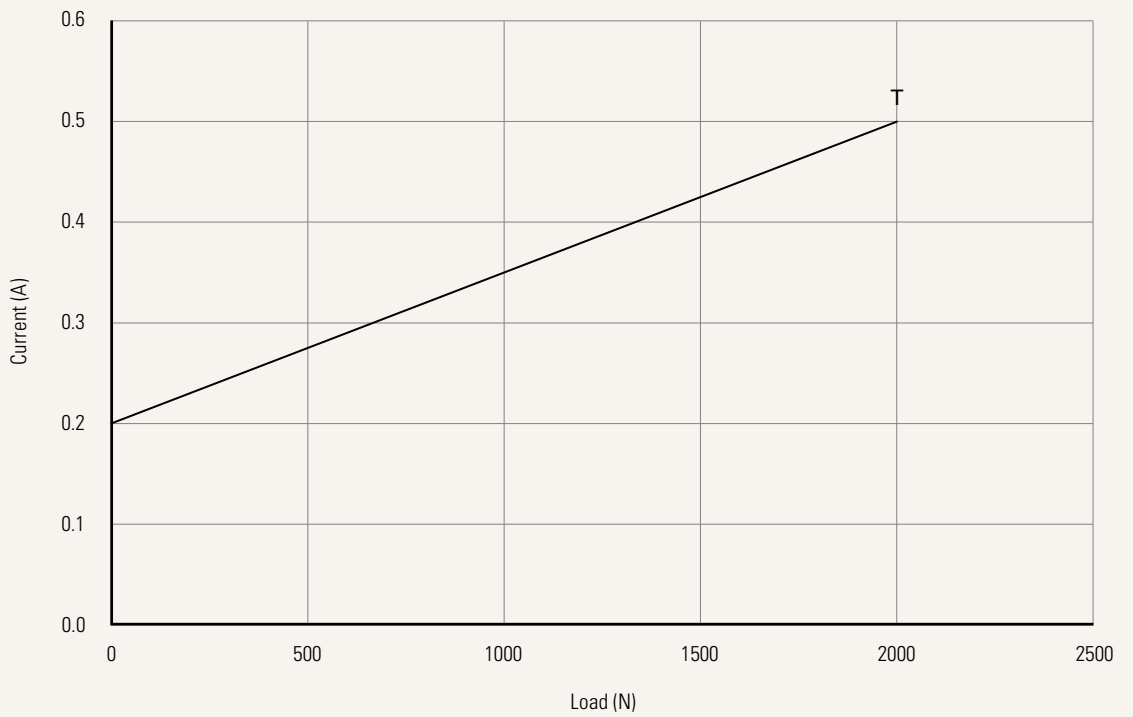

| | | | | |
|---|--|---|------------------------------------|--------------------|
| Voltage See page 24 | 1 = 12V DC 2 = 24V DC | 3 = 36V DC 4 = 48V DC | 5 = 24V DC, PTC 6 = 12V DC, PTC | 8 = 48V DC, PTC |
| Load and Speed | See page 3-5 | | | |
| Stroke (mm) | See page 3 | | | |
| Retracted Length (mm) | See page 23 | | | |
| Rear Attachment (mm) See page 24 | 1 = Aluminum, slotless, hole 6.4, one piece casting with gearbox 2 = Aluminum, slotless, hole 8.0, one piece casting with gearbox 3 = Aluminum, slotless, hole 10.0, one piece casting with gearbox 4 = Aluminum, U clevis, slot 6.0, depth 10.5, hole 6.4, one piece casting with gearbox 5 = Aluminum, U clevis, slot 6.0, depth 10.5, hole 8.0, one piece casting with gearbox 6 = Aluminum, U clevis, slot 6.0, depth 10.5, hole 10.0, one piece casting with gearbox | | | |
| Front Attachment (mm) See page 25 | 1 = Aluminum, slotless, hole 6.4 2 = Aluminum, slotless, hole 8.0 6 = Aluminum, slotless, hole 10.0 | 3 = Aluminum, U clevis, slot 6.0, depth 16.0, hole 10.0 4 = Aluminum, U clevis, slot 6.0, depth 16.0, hole 6.4 5 = Aluminum, U clevis, slot 6.0, depth 16.0, hole 8.0 | | |
| Direction of Rear Attachment (Counterclockwise) See page 25 | 1 = 90° | 2 = 0° | | |
| Function of Limit Switches See page 26 | 1 = Two micro switches cut off the actuator at end of stroke (EOS) 2 = Two micro switches cut off the actuator at EOS + in-between third one sends signal 3 = Two switches at full retracted / extended positions to send signal 4 = Two switches at full retracted / extended positions to send signal + third one in between to send signal | | | |
| Output Signal See page 26 | 0 = Without 1 = Mechanical pot. | N = Hall sensor * 2 (5-36V input) | | |
| Connector (mm) See page 25 | 1 = DIN 6P, 90° plug 2 = Tinned leads | S = AMP superseal 1.5, 2 pins plug | | |
| Cable Length (mm) | 0 = Straight, 100 | 1 = Straight, 300 | 2 = Straight, 600 | 3 = Straight, 1000 |
| IP Rating | 1 = Without | 2 = IP54 | 3 = IP66 | 6 = IP66M |

Retracted Length (mm)

1. Calculate $A+B+C = Y$
2. Retracted length needs to \geq Stroke + Y
3. Min. retracted length related with IP: When choosing IP66M, the min. retracted length should comply with the table below.

A. Attachment

| Front Attachment | Rear Attachment | |
|------------------|-----------------|---------|
| | 1, 2, 3 | 4, 5, 6 |
| 1, 2, 6 | +108 | +112 |
| 3, 4, 5 | +120 | +124 |

IP66M Min. Retracted length

| Front Attachment | Rear Attachment | |
|------------------|-----------------|------------|
| | 1, 2, 3 | 4, 5, 6 |
| 1, 2, 6 | ≥ 174 | ≥ 178 |
| 3, 4, 5 | ≥ 187 | ≥ 191 |

B. Load VS. Stroke

| Stroke (mm) | Load (N) | |
|-----------------|----------|--------|
| | < 3500 | = 3500 |
| 20~150 | - | +5 |
| 151~200 | +2 | +7 |
| 201~250 | +2 | +7 |
| 251~300 | +2 | +7 |
| 301~350 | +12 | +17 |
| 351~400 | +22 | +27 |
| 401~450 | +32 | +37 |
| 451~500 | +42 | +47 |
| 501~550 | +52 | +57 |
| 551~600 | +62 | +67 |
| 601~650 | +72 | +77 |
| 651~700 | +82 | +87 |
| 701~750 | +92 | +97 |
| 751~800 | +102 | +107 |
| 801~850 | +112 | +117 |
| 851~900 | +122 | +127 |
| 901~950 | +132 | +137 |
| 951~1000 | +142 | +147 |

C. Output Signals

| CODE | |
|-------------|-----|
| 0, N | - |
| 1 | +30 |

Voltage

5 = 24V DC, PTC

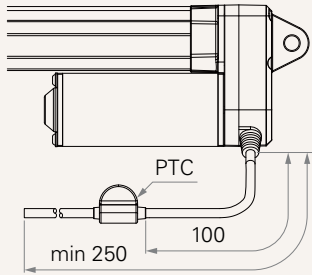

6 = 12V DC, PTC

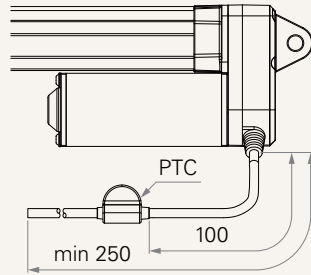

8 = 48V DC, PTC

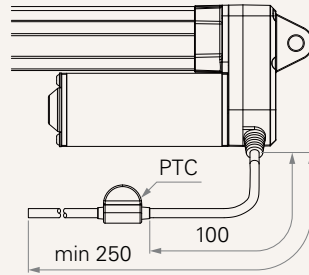

Rear Attachment (mm)

1 = Aluminum, slotless, hole 6.4, one piece casting with gearbox

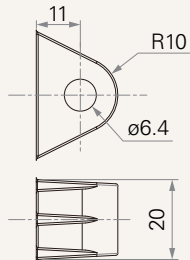

2 = Aluminum, slotless, hole 8.0, one piece casting with gearbox

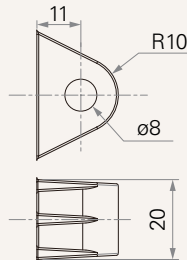

3 = Aluminum, slotless, hole 10.0, one piece casting with gearbox

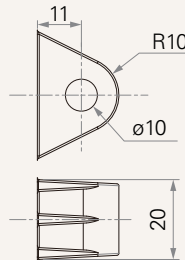

4 = Aluminum, U clevis, slot 6.0, depth 10.5, hole 6.4, one piece casting with gearbox

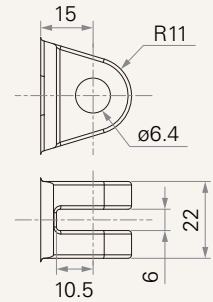

5 = Aluminum, U clevis, slot 6.0, depth 10.5, hole 8.0, one piece casting with gearbox

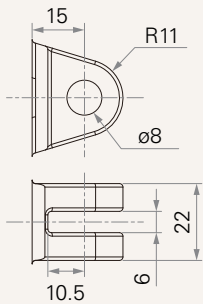

6 = Aluminum, U clevis, slot 6.0, depth 10.5, hole 10.0, one piece casting with gearbox

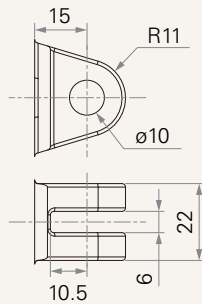

Front Attachment (mm)

1 = Aluminum, slotless, hole 6.4

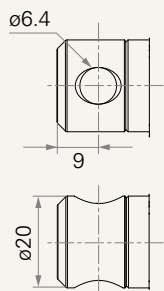

2 = Aluminum, slotless, hole 8.0

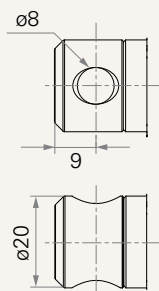

3 = Aluminum, U clevis, slot 6.0, depth 16.0, hole 10.0

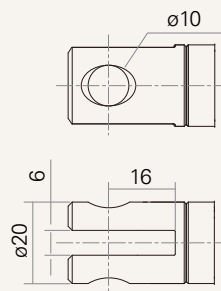

4 = Aluminum, U clevis, slot 6.0, depth 16.0, hole 6.4

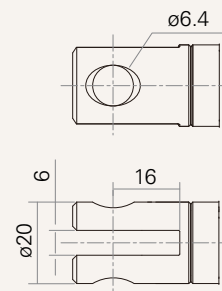

5 = Aluminum, U clevis, slot 6.0, depth 16.0, hole 8.0

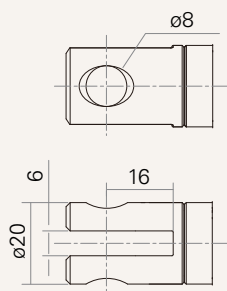

6 = Aluminum, slotless, hole 10.0

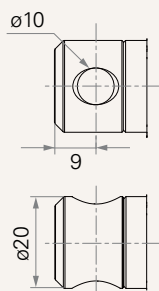

Direction of Rear Attachment (Counterclockwise)

1 = 90°

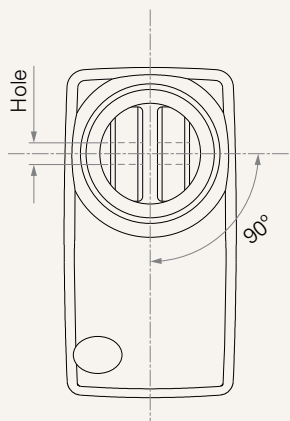

2 = 0°

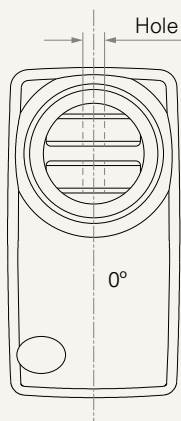

Connector (mm)

1 = DIN 6P, 90° plug

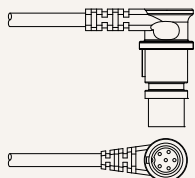

2 = Tinned leads

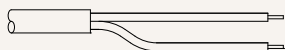

S = AMP superseal 1.5, 2 pins plug

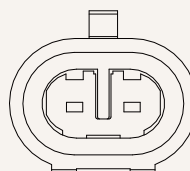

Wire Definition

| Port | Function of Limit Switches | Wire Color | Wire Gauge (AWG) | Output Signal | | |
|------|--|------------|------------------|---------------|--------------------|--------------------|
| | | | | 0. Without | 1. Mechanical pot. | N. Hall sensor * 2 |
| A1 | 1. Two micro switches cut off the actuator at end of stroke (EOS) | ● GN | 20 | EXT+ | EXT+ | EXT+ |
| | | ● YE | 20 | RET+ | RET+ | RET+ |
| | | ● RD | 26 | - | POT-out | Vcc+ |
| | | ○ WH | 26 | - | POT-Vin (+5V) | S1 |
| | | ● BK | 26 | - | GND | Hall-GND |
| | | ● BU | 26 | - | - | S2 |
| | | ● BN | 26 | - | - | - |
| | | ● GY | 26 | - | - | - |
| | | ● OG | 26 | - | - | - |
| | | ● VT | 26 | - | - | - |
| A1 | 2. Two micro switches cut off the actuator at EOS + in-between third one sends signal | ● GN | 20 | EXT+ | EXT+ | EXT+ |
| | | ● YE | 20 | RET+ | RET+ | RET+ |
| | | ● RD | 26 | - | - | Vcc+ |
| | | ○ WH | 26 | 3rd LS pin1 | POT-Vout | S1 |
| | | ● BK | 26 | 3rd LS pin2 | POT-Vin (+5V) | Hall-GND |
| | | ● BU | 26 | - | POT-GND | S2 |
| | | ● BN | 26 | - | 3rd LS pin2 | 3rd LS pin1 |
| | | ● GY | 26 | - | 3rd LS pin1 | - |
| | | ● OG | 26 | - | - | 3rd LS pin2 |
| | | ● VT | 26 | - | - | - |
| A1 | 3. Two micro switches send signal at end of stroke | ● GN | 20 | EXT+ | EXT+ | EXT+ |
| | | ● YE | 20 | RET+ | RET+ | RET+ |
| | | ● RD | 26 | LS-COM | LS-COM | Vcc+ |
| | | ○ WH | 26 | UP LS | UP LS | S1 |
| | | ● BK | 26 | - | POT-GND | Hall-GND |
| | | ● BU | 26 | LOW LS | LOW LS | S2 |
| | | ● BN | 26 | - | POT-Vin (+5V) | UP LS |
| | | ● GY | 26 | - | - | - |
| | | ● OG | 26 | - | POT-Vout | LOW LS |
| | | ● VT | 26 | - | - | LS-COM |
| A1 | 4. Two micro switches send signal at end of stroke + in-between third one sends signal | ● GN | 20 | EXT+ | EXT+ | EXT+ |
| | | ● YE | 20 | RET+ | RET+ | RET+ |
| | | ● RD | 26 | LS-COM | LS-COM | Vcc+ |
| | | ○ WH | 26 | UP LS | UP LS | S1 |
| | | ● BK | 26 | 3rd LS pin1 | 3rd LS pin1 | Hall-GND |
| | | ● BU | 26 | LOW LS | LOW LS | S2 |
| | | ● BN | 26 | - | POT-Vin (+5V) | UP LS |
| | | ● GY | 26 | - | - | 3rd LS |
| | | ● OG | 26 | - | POT-Vout | LOW LS |
| | | ● VT | 26 | - | POT-GND | LS-COM |

Terms of Use

The user is responsible for determining the suitability of TiMOTION products for a specific application. TiMOTION products are subject to change without prior notice.