

TA38

series



Product Segments

- **Comfort Motion**
- **Industrial Motion**

TiMOTION's TA38 series linear actuator is specially designed for low-noise applications, or where a compact linear actuator is needed. The TA38 features a very slim design with a small installation size of only 160mm, providing manufacturers great freedom during the design process. The palm sized motor with up to 1500N force is excellent for all kinds of space limited products.

General Features

| | |
|-------------------------------|---------------------------------------|
| Max. load | 1,500N (push/pull) |
| Max. speed at max. load | 9mm/s |
| Max. speed at no load | 15.7mm/s |
| Retracted length | ≥ 160mm (depending on chosen options) |
| IP rating | IP66 |
| Stroke | 20~200mm |
| Output signals | Hall sensors |
| Voltage | 24V DC; 12/24V DC (PTC) |
| Color | Black or grey |
| Operational temperature range | +5°C~+45°C |

Drawing

Standard Dimensions
(mm)

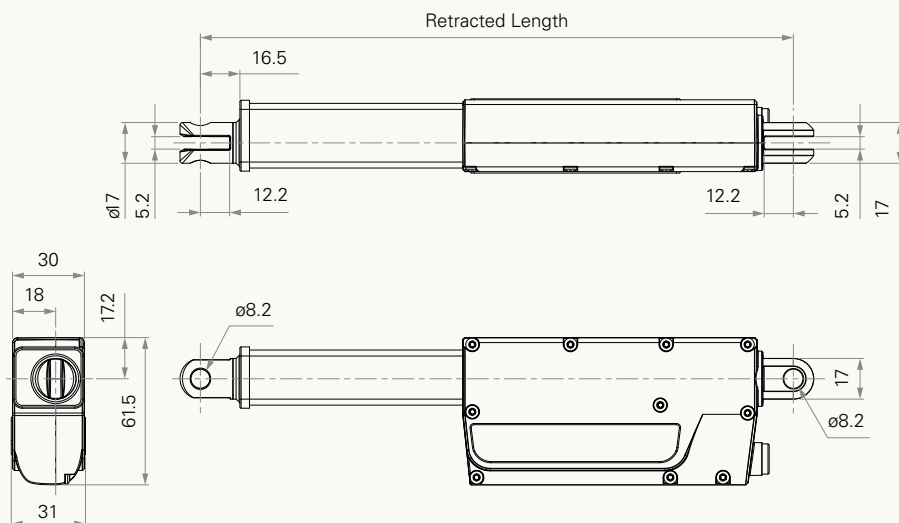

Load and Speed

| CODE | Load (N) | | Self Locking Force (N) | Typical Current (A) | | Typical Speed (mm/s) | |
|--|----------|------|------------------------|---------------------|------------------|----------------------|------------------|
| | Push | Pull | | No Load 32V DC | With Load 24V DC | No Load 32V DC | With Load 24V DC |
| Motor Speed (6000RPM, Duty Cycle 10%) | | | | | | | |
| B | 1500 | 1500 | 1200 | 1.3 | 3.6 | 15.7 | 9.0 |

Note

- 1 Please refer to the approved drawing for the final authentic value.
- 2 This self-locking force level is reached only when a short circuit is applied on the terminals of the motor. All the TiMOTION control boxes have this feature built-in.
- 3 The current & speed in table are tested with 24V DC motor. With a 12V DC motor, the current is approximately twice the current measured in 24V DC; speed will be similar for both voltages.
- 4 The current & speed in table are tested when the actuator is extending under push load.
- 5 The current & speed in table and diagram are tested with TiMOTION control boxes, and there will be around 10% tolerance depending on different models of the control box. (Under no load condition, the voltage is around 32V DC. At rated load, the voltage output will be around 24V DC)
- 6 Standard stroke: Min. ≥ 20 mm, Max. please refer to below table.

| CODE | Load (N) | Max Stroke (mm) |
|----------|-------------|-----------------|
| B | ≤ 1500 | 200 |

Performance Data (24V DC Motor)

Motor Speed (6000RPM, Duty Cycle 10%)

Speed vs. Load

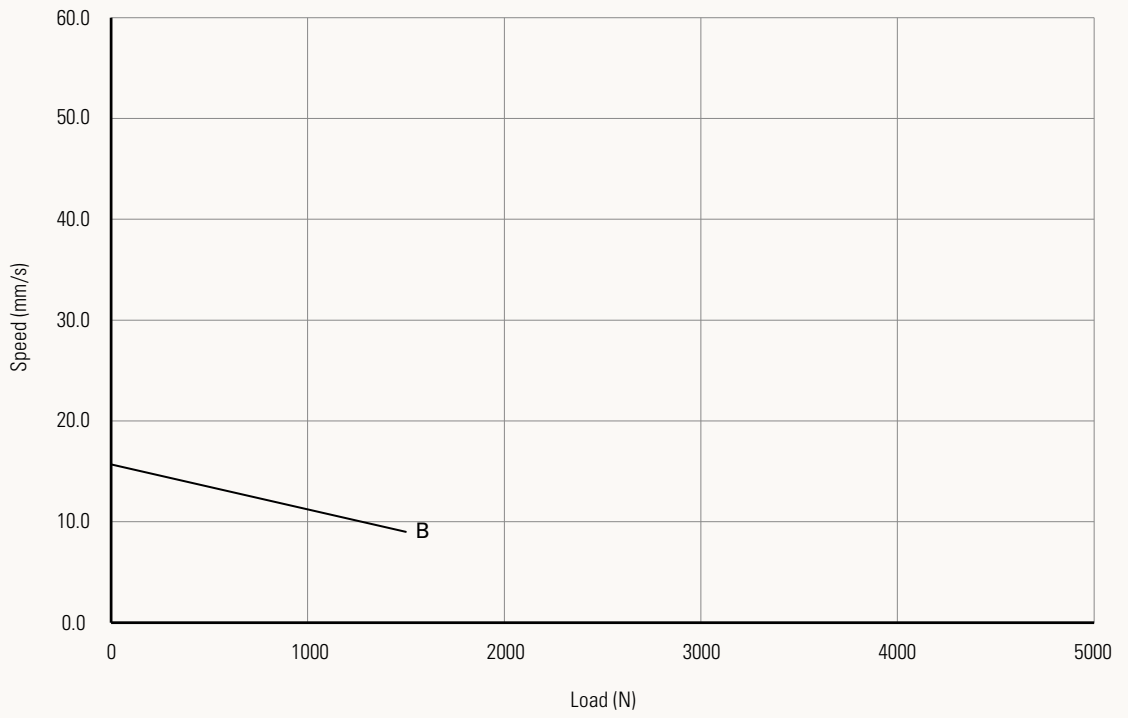

Current vs. Load

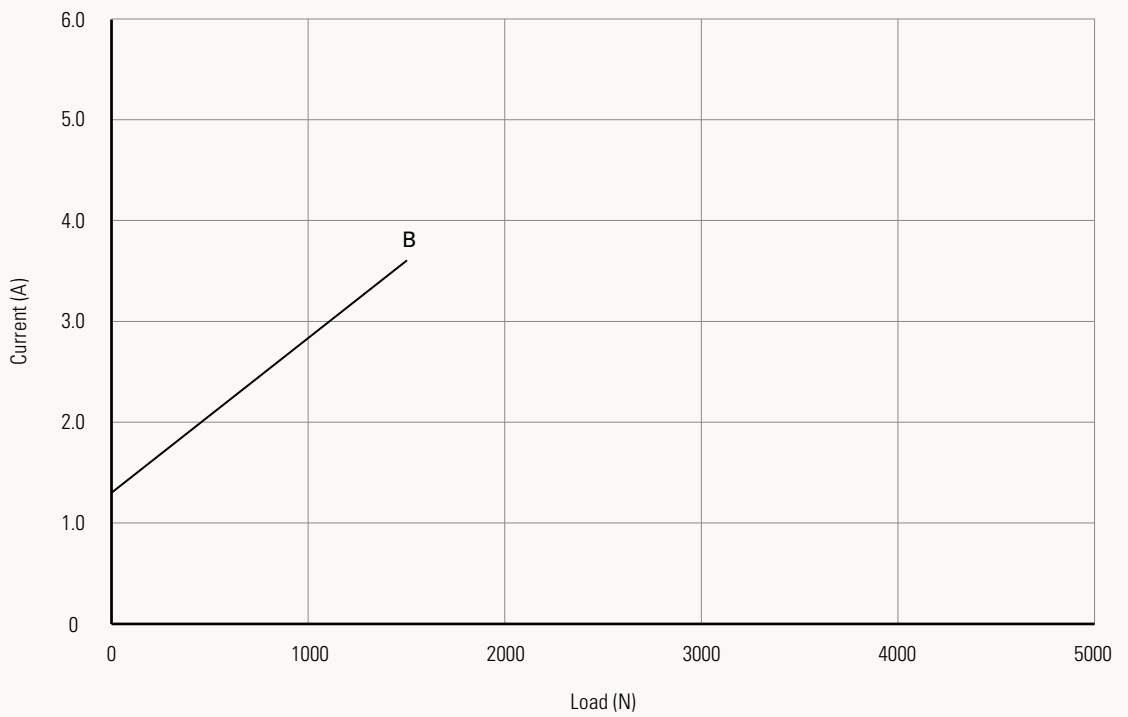

| | | | |
|--|--|--|---|
| Voltage See page 5 | 2 = 24V DC | 5 = 24V DC, PTC | 6 = 12V DC, PTC |
| Load and Speed See page 2 | | | |
| Stroke (mm) See page 2 | | | |
| Retracted Length (mm) See page 5 | | | |
| Rear Attachment (mm) See page 5 | E = Aluminum casting, U clevis, width 5.2, depth 12.2, hole 6.2 | G = Aluminum casting, U clevis, width 5.2, depth 12.2, hole 8.2 | |
| Front Attachment (mm) See page 5 | E = Aluminum casting, U clevis, width 5.2, depth 12.2, hole 6.2 | G = Aluminum casting, U clevis, width 5.2, depth 12.2, hole 8.2 | |
| Direction of Rear Attachment (Counterclockwise) See page 6 | 1 = 90° (Standard) | 2 = 0° | |
| Color | 1 = Black | 2 = Pantone 428C | |
| IP Rating | 1 = Without | 2 = IP54 | 3 = IP66 |
| Special Functions for Spindle Sub-Assembly | 0 = Without | | |
| Functions for Limit Switches See page 6 | 1 = Two switches at full retracted / extended positions to cut current | 3 = Two switches at full retracted / extended positions to send signal | |
| Output Signals | 0 = Without | 5 = Hall sensor * 2 | |
| Connector See page 7 | 1 = DIN 6P, 90° plug 2 = Tinned leads 4 = Big 01P, plug | C = Y cable (For direct cut system, water proof, anti pull) | E = Molex 8P, plug F = DIN 6P, 180° plug |
| Cable Length (mm) | 0 = Straight, 100 1 = Straight, 500 2 = Straight, 750 | 3 = Straight, 1000 4 = Straight, 1250 5 = Straight, 1500 | 6 = Straight, 2000 7 = Curly, 200 8 = Curly, 400 B-H = For direct cut system. See page 7 |

Retracted Length (mm)

1. Calculate $A+B = Y$
2. Retracted length needs to $\geq \text{Stroke}+Y$

| A. | | B. | |
|----------------------|---------------------|--------------------|---|
| Front Attach. | Rear Attach. | Stroke (mm) | |
| E, G | E, G | 20~200 | - |
| E, G | + 115 | | |

Voltage

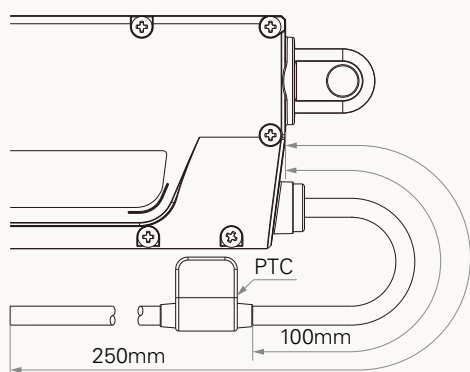

Rear Attachment (mm)

E = Aluminum casting, U clevis, width 5.2, depth 12.2, hole 6.2

G = Aluminum casting, U clevis, width 5.2, depth 12.2, hole 8.2

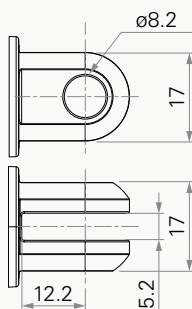
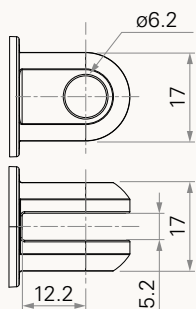

Front Attachment (mm)

E = Aluminum casting, U clevis, width 5.2, depth 12.2, hole 6.2

G = Aluminum casting, U clevis, width 5.2, depth 12.2, hole 8.2

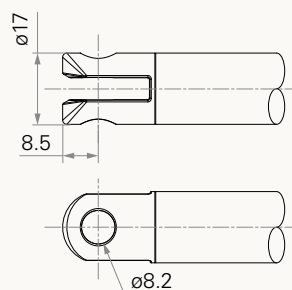
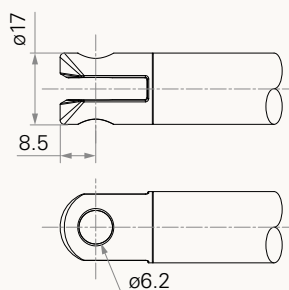

Direction of Rear Attachment (Counterclockwise)

1 = 90° (Standard)

2 = 0°

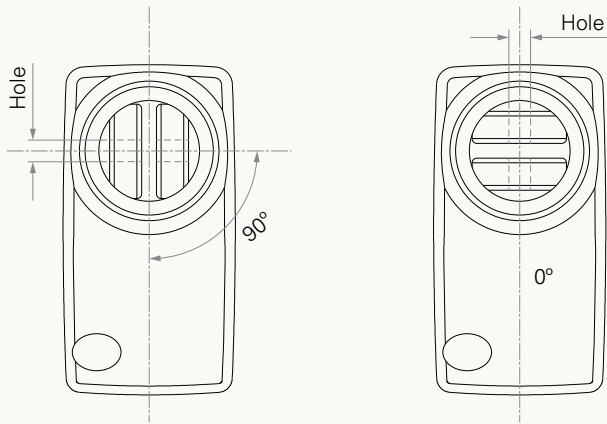

Functions for Limit Switches

Wire Definitions

| CODE | Pin | | | | | |
|----------|---------------|-----------|--------------------|-------------|----------------|--------------------|
| | ● 1 (Green) | ● 2 (Red) | ○ 3 (White) | ● 4 (Black) | ● 5 (Yellow) | ● 6 (Blue) |
| 1 | extend (VDC+) | N/A | N/A | N/A | retract (VDC+) | N/A |
| 3 | extend (VDC+) | common | upper limit switch | N/A | retract (VDC+) | lower limit switch |

Connector

1 = DIN 6P, 90° plug

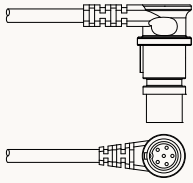

2 = Tinned leads



4 = Big 01P, plug

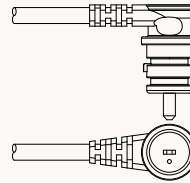

C = Y cable (direct cut, water proof, anti-pull)

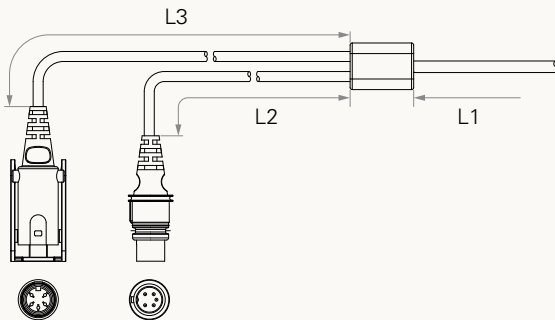

Cable Length for Direct Cut System (mm)

| CODE | L1 | L2 | L3 |
|------|------|------|------|
| B | 100 | 100 | 100 |
| C | 100 | 1000 | 400 |
| D | 100 | 2700 | 500 |
| E | 1000 | 100 | 100 |
| F | 100 | 600 | 1000 |
| G | 1500 | 1000 | 1000 |
| H | 100 | 100 | 1200 |

E = Molex 8P, plug

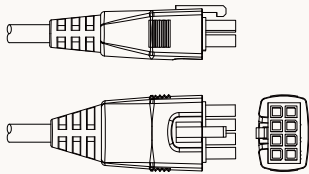

F = DIN 6P, 180° plug

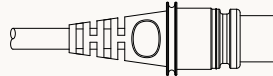

Terms of Use

The user is responsible for determining the suitability of TiMOTION products for a specific application. TiMOTION products are subject to change without prior notice.