

TA50

series



Product Segments

- **Care Motion**

The TA50 is an innovative addition to TiMOTION's CARE line of electric linear actuators.

Featuring a cylindrical design, it incorporates an internal limit switch assembly installed inside the gearbox. Additionally, offering a robust load capacity of up to 8,000N and a waterproof rating of IP66W, the TA50 is suitable for a wide variety of medical products, including electric hospital beds, bathroom chairs, and homecare medical beds.

General Features

Max. load	8,000N (push); 3,000N (pull)
Max. speed at max. load	3.6mm/s
Max. speed at no load	15.7mm/s
Retracted length	≥ Stroke + 150mm
IP rating	IP66W
Certificate	EN60601-1
Stroke	25~450mm
Output signals	Hall sensor * 2
Voltage	24V DC; 24V DC (PTC)
Color	Grey
Operational temperature range at full performance	+5°C~+45°C

Drawing

Standard Dimensions
(mm)

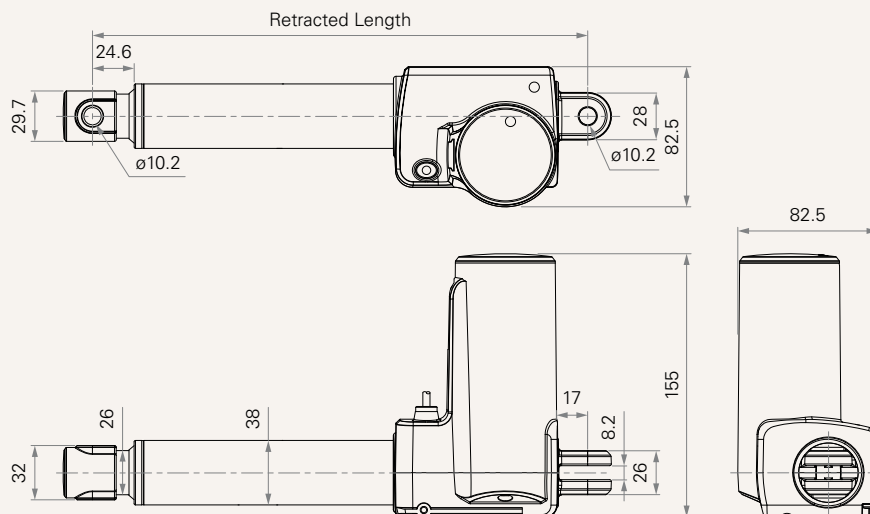

Load and Speed

CODE	Load (N)		Self Locking Force (N)	Typical Current (A)		Typical Speed (mm/s)	
	Push	Pull		No Load 32V DC	With Load 24V DC	No Load 32V DC	With Load 24V DC
Motor Speed (4500RPM, Duty Cycle 10%)							
C	8000	3000	8000	≤ 1.2	5.2 ± 1.1	6.6 ± 0.4	3.6 ± 0.6
D	6000	3000	6000	≤ 1.2	4.1 ± 0.9	7.7 ± 0.5	4.5 ± 0.5
E	4000	3000	4000	≤ 1.2	5.0 ± 1.0	13.6 ± 0.6	8.2 ± 0.8
F	3000	3000	3000	≤ 1.2	4.5 ± 0.9	15.7 ± 0.7	9.0 ± 0.9
Motor Speed (3800RPM, Duty Cycle 10%)							
H	8000	3000	8000	≤ 1.1	4.7 ± 0.9	6.0 ± 0.4	3.0 ± 0.4
I	6000	3000	6000	≤ 1.1	4.0 ± 0.6	6.9 ± 0.6	3.6 ± 0.4
J	4000	3000	4000	≤ 1.1	4.1 ± 1.0	11.7 ± 0.9	6.4 ± 0.8
K	3000	3000	3000	≤ 1.1	3.9 ± 0.8	13 ± 1.0	7.8 ± 0.8

Note

- 1 Please refer to the approved drawing for the final authentic value.
- 2 This self-locking force level is reached only when a short circuit is applied on the terminals of the motor. All the TiMOTION control boxes have this feature built-in.
- 3 The current & speed in table are tested with 24V DC motor. With a 12V DC motor, the current is approximately twice the current measured in 24V DC; speed will be similar for both voltages.
- 4 The current & speed in table are tested when the actuator is extending under push load.
- 5 The current & speed in table and diagram are tested with TiMOTION control boxes, and there will be around 10% tolerance depending on different models of the control box. (Under no load condition, the voltage is around 32V DC. At rated load, the voltage output will be around 24V DC)
- 6 Standard stroke: Min. ≥ 25 mm, Max. please refer to below table.

CODE	Load (N)	Max Stroke (mm)
E, J	4000	400
F, K	3000	450
D, I	6000	250
C, H	8000	250

Performance Data (24V DC Motor)

Motor Speed (4500RPM)

Speed vs. Load

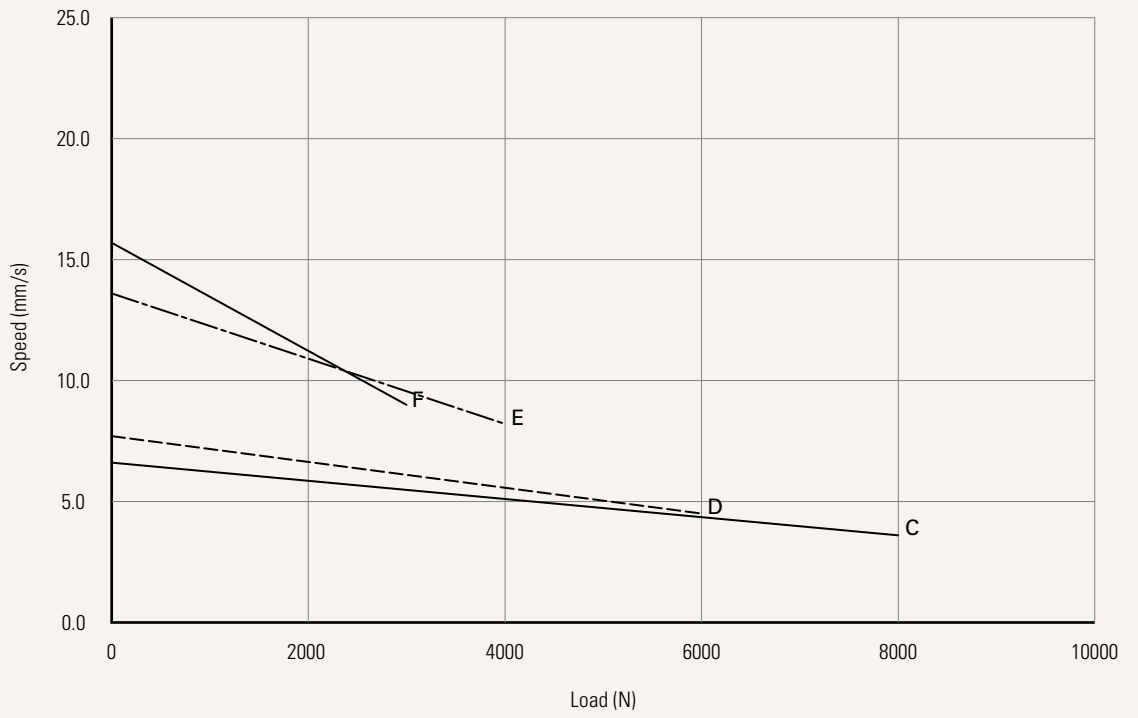

Current vs. Load

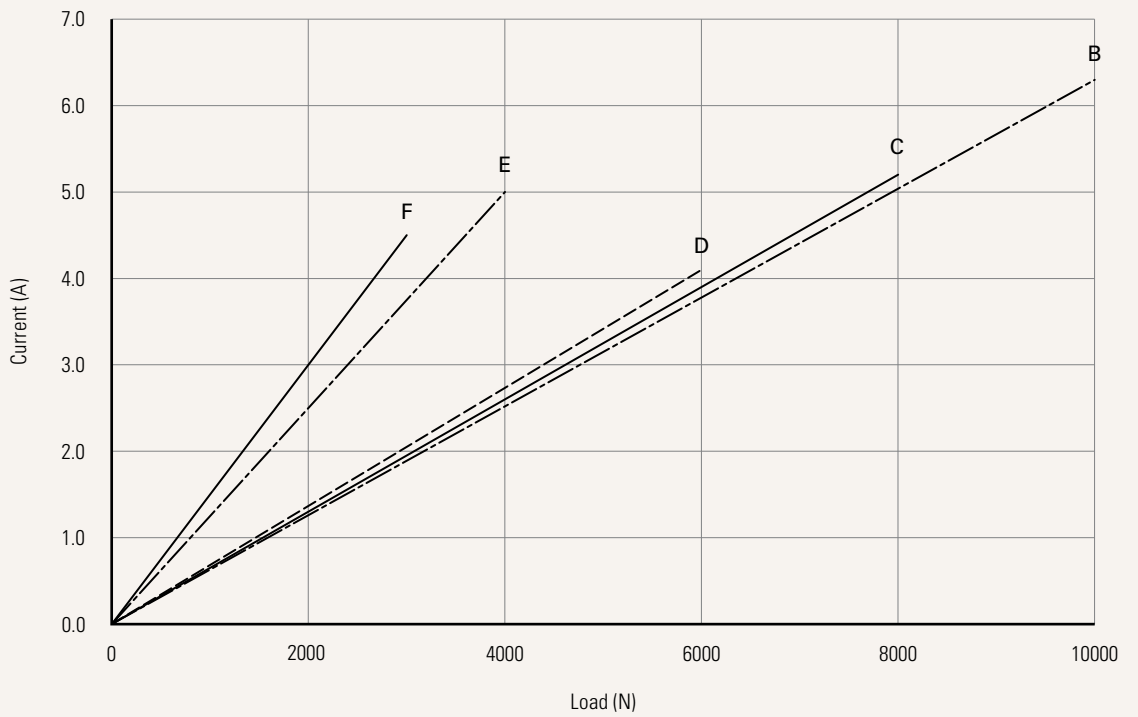

Performance Data (24V DC Motor)

Motor Speed (3800RPM)

Speed vs. Load

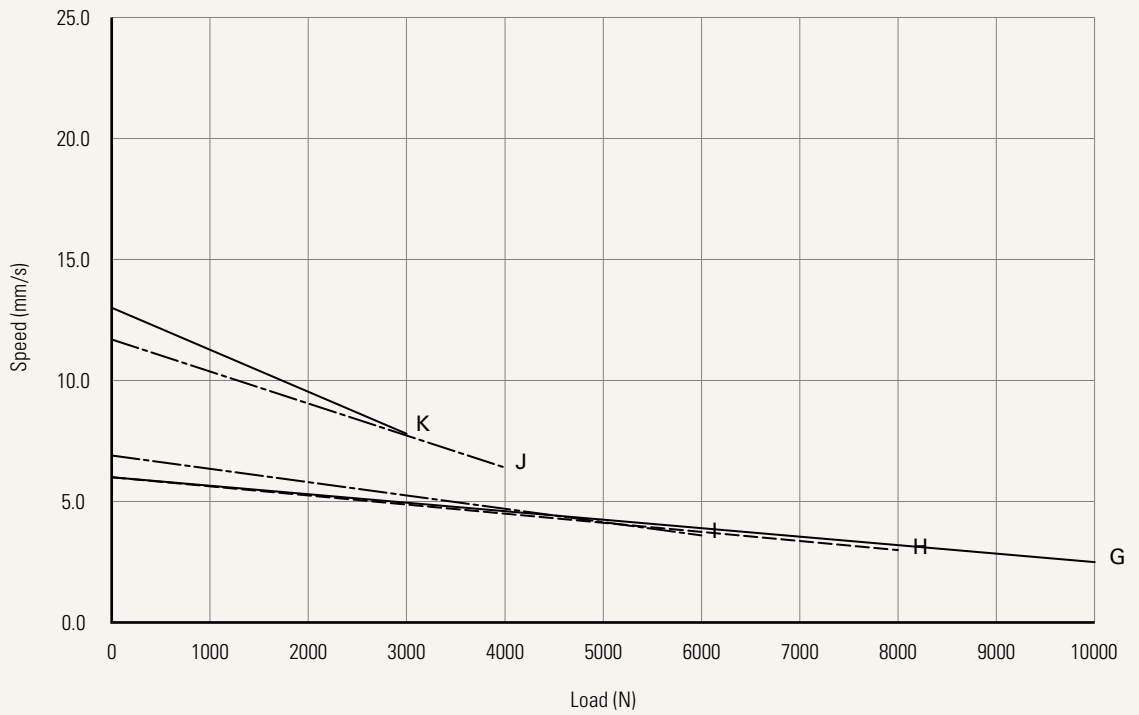

Current vs. Load

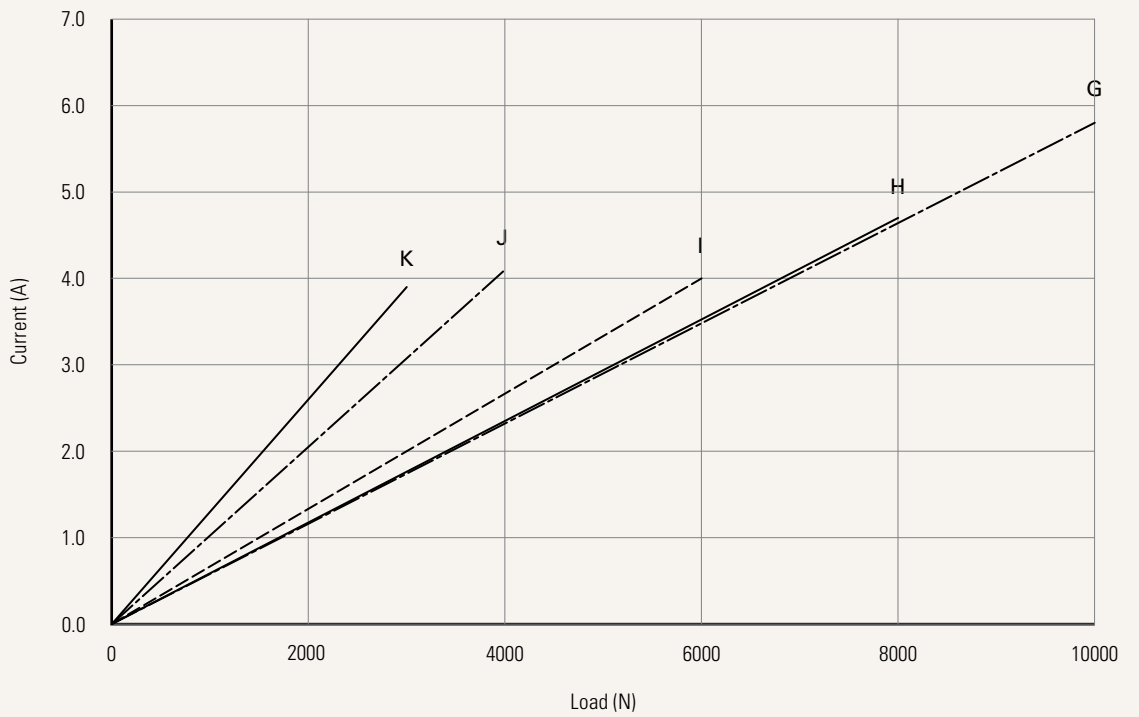

Voltage	2 = 24V DC	5 = 24V DC, PTC		
Load and Speed	See page 2			
Stroke (mm)	See page 2			
Retracted Length (mm)	See page 6			
Rear Attachment (mm)	2 = Plastic, U clevis, width 8.2, depth 17.0, hole 10.2 (for push < 4000N) 3 = Plastic, U clevis, width 8.2, depth 17.0, hole 12.2 (for push < 4000N) 4 = Aluminum casting, U clevis, width 8.2, depth 17.0, hole 10.2 5 = Aluminum casting, U clevis, width 8.2, depth 17.0, hole 12.2			
Front Attachment (mm)	1 = Punched hole on inner Aluminum tube + plastic cap, without slot, hole 10.2, plastic bush 2 = Punched hole on inner Aluminum tube + plastic cap, without slot, hole 12.2 3 = Plastic, U clevis, width 8.2, depth 20.0, hole 10.2 (for push < 4000N, pull < 2500N) 4 = Plastic, U clevis, width 8.2, depth 20.0, hole 12.2 (for push < 4000N, pull < 2500N) 5 = Punched hole on inner Aluminum tube, without slot, hole 10.2, plastic bush 6 = Punched hole on inner Aluminum tube, without slot, hole 12.2 7 = Aluminum casting, U clevis, width 6.2, depth 17.0, hole 10.2 8 = Aluminum casting, U clevis, width 6.2, depth 17.0, hole 12.2 9 = Aluminum casting, U clevis, width 6.2, depth 17.0, hole 10.2, T bush			
Direction of Rear Attachment (Counterclockwise)	1 = 0°	3 = 90°		
Color	2 = 428C (LAB)			
IP Rating	1 = Without	2 = IP54	3 = IP66	5 = IP66W
Special Function of Spindle Subassembly	0 = Without (Standard) 1 = Safety nut		2 = Standard push only	
Function for Limit Switches	1 = Two switches at full retracted/extended positions to cut current			
Output Signal	0 = Without		2 = Hall sensor * 2	
Connector	1 = DIN 6P, 90° plug F = DIN 6P, 180° plug		Q = Molex 6P, 90° plug, without anti-clip S = Molex 6P, 180° plug, without anti-clip	
Cable	1 = Standard (Can not used tinned leads)			
Cable Length (mm)	0 = Straight, 100 1 = Straight, 500	3 = Straight, 1000 5 = Straight, 1500	6 = Straight, 2000 7 = Curly, 200	8 = Curly, 400

Retracted Length (mm)

1. Calculate $A+B+C = Y$
2. Retracted length needs to \geq Stroke+Y

A.	
Front Attach.	Rear Attach.
	General
	2, 3, 4, 5
1, 2, 5, 6	+150
3, 4	+165
7, 8, 9	+175
B, C	+173

B.				
Stroke (mm)	Load (N)			
	< 6000	= 6000	= 8000	=10000
25~150	-	-	-	+9
151~200	-	-	-	+9
201~250	+10	+10	+10	+19
251~300	+20	+20	+20	+29
301~350	+30	+30	+30	+39
351~400	+40	+40	+40	+49
401~450	+50	+50	+50	+59

C.		
Front Attach.	Spindle function	
	0	2
1, 2, 5, 6	-	+15
3, 4	-	+15
7, 8, 9	-	+15

Rear Attachment (mm)

2 = Plastic, U clevis, width 8.2, depth 17.0, hole 10.2 (for push < 4000N)

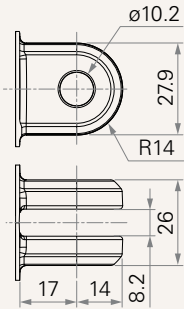

3 = Plastic, U clevis, width 8.2, depth 17.0, hole 12.2 (for push < 4000N)

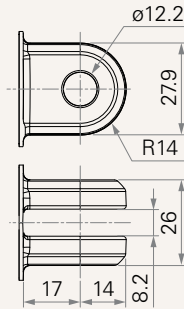

4 = Aluminum casting, U clevis, width 8.2, depth 17.0, hole 10.2

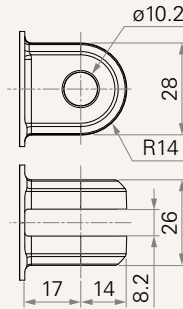

5 = Aluminum casting, U clevis, width 8.2, depth 17.0, hole 12.2

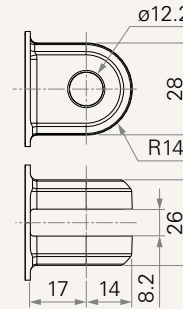

Front Attachment (mm)

1 = Punched hole on inner Aluminum tube + plastic cap, without slot, hole 10.2, plastic bush

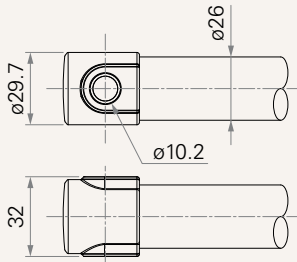

2 = Punched hole on inner Aluminum tube + plastic cap, without slot, hole 12.2

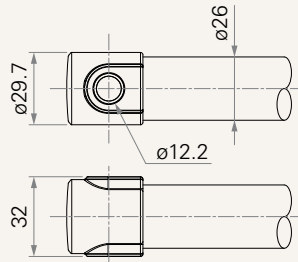

3 = Plastic, U clevis, width 8.2, depth 20.0, hole 10.2 (for push < 4000N, pull < 2500N)

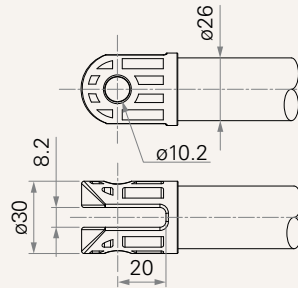

4 = Plastic, U clevis, width 8.2, depth 20.0, hole 12.2 (for push < 4000N, pull < 2500N)

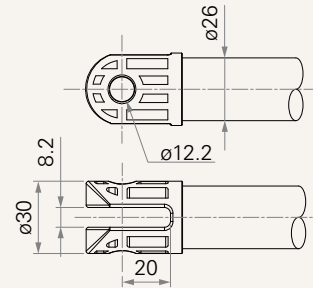

5 = Punched hole on inner Aluminum tube, without slot, hole 10.2, plastic bush

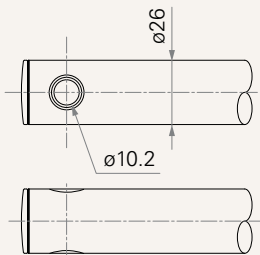

6 = Punched hole on inner Aluminum tube, without slot, hole 12.2

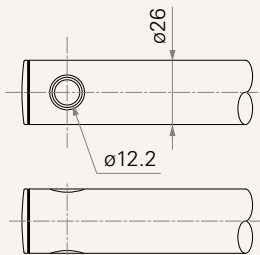

7 = Aluminum casting, U clevis, width 6.2, depth 17.0, hole 10.2

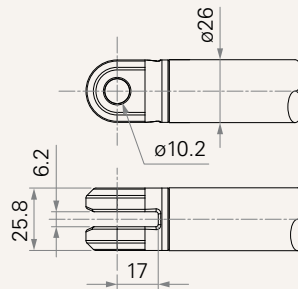

8 = Aluminum casting, U clevis, width 6.2, depth 17.0, hole 12.2

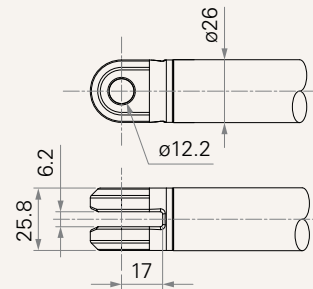

9 = Aluminum casting, U clevis, width 6.2, depth 17.0, hole 10.2, T bush

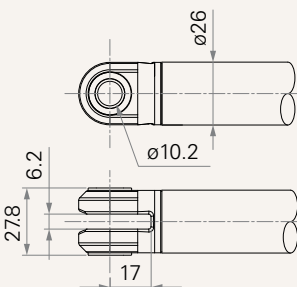

Direction of Rear Attachment (Counterclockwise)

1 = 0°

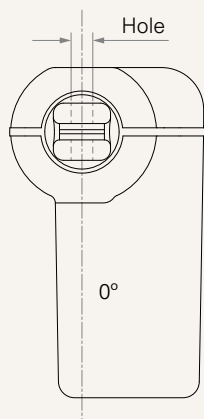

3 = 90°

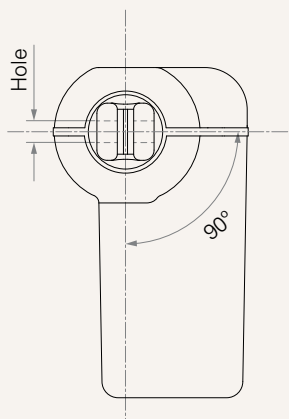

Functions for Limit Switches

Wire Definitions

CODE	Pin					
	1 (Green)	2 (Red)	3 (White)	4 (Black)	5 (Yellow)	6 (Blue)
1	extend (VDC+)	N/A	N/A	N/A	retract (VDC+)	N/A

Connector

1 = DIN 6P, 90° plug

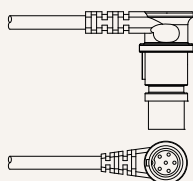

F = DIN 6P, 180° plug

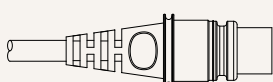

Q = Molex 6P, 90° plug, without anti-clip

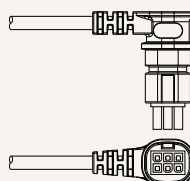

S = Molex 6P, 180° plug, without anti-clip

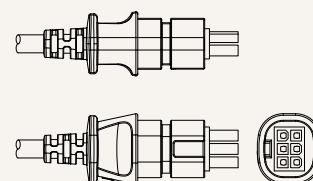

Terms of Use

The user is responsible for determining the suitability of TiMOTION products for a specific application. TiMOTION products are subject to change without prior notice.