

# FOR HEIGHT ADJUSTABLE TOUCHSCREENS OR LIFTS

Choose TiMOTION for Flexibility,  
Customized Products, and Tailor-Made Services

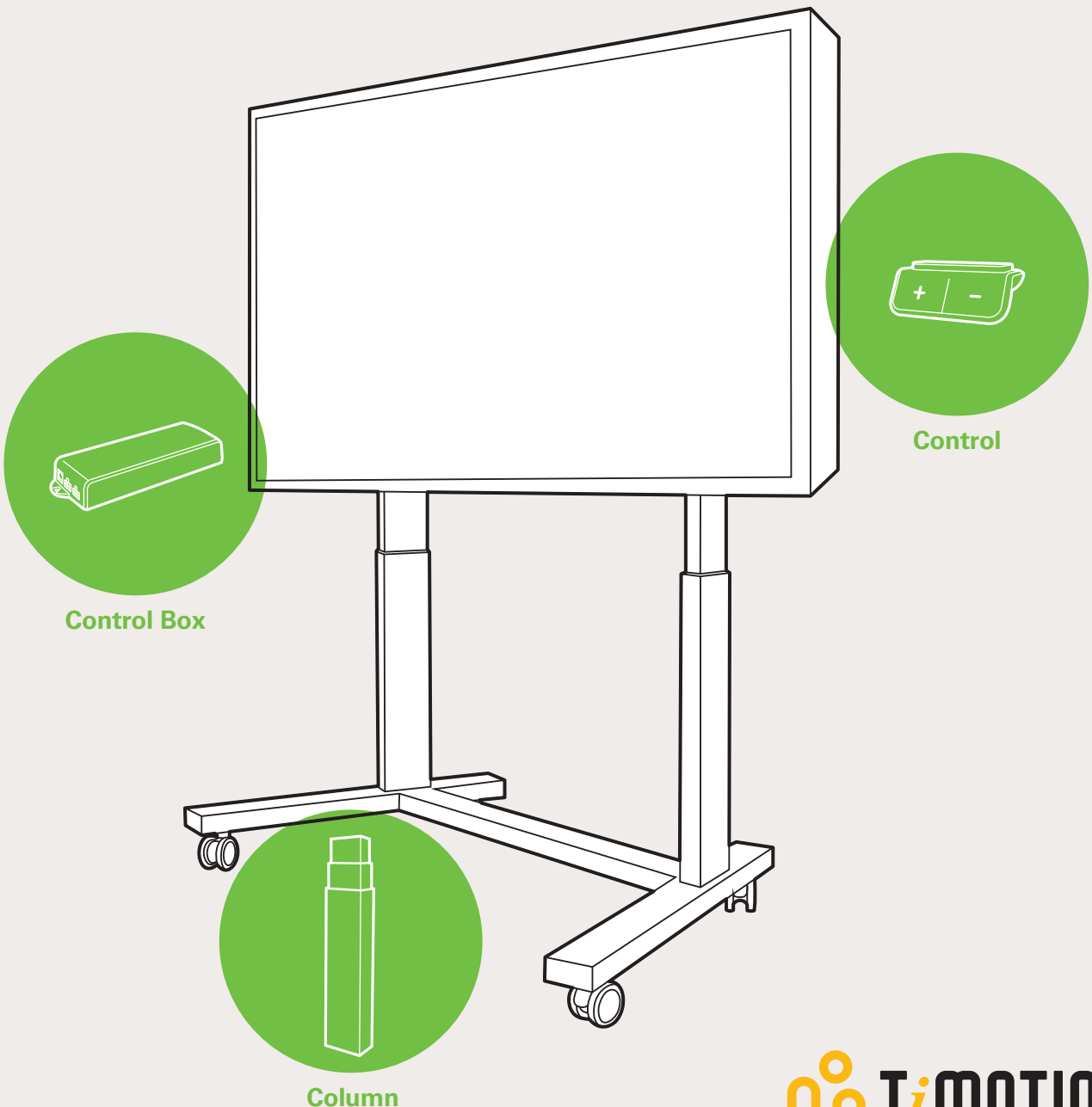

TiMOTION provides a wide range of actuation system equipped with multiple columns, control boxes, and controls for the manufacturers to choose from. The TiMOTION column series are primarily designed for lifting applications, such as the height adjustable touchscreens that require vertical movement.

## Key Features of TiMOTION Actuation Systems

- Quiet Operation
- High Lifting Capacity
- Multiple Controls

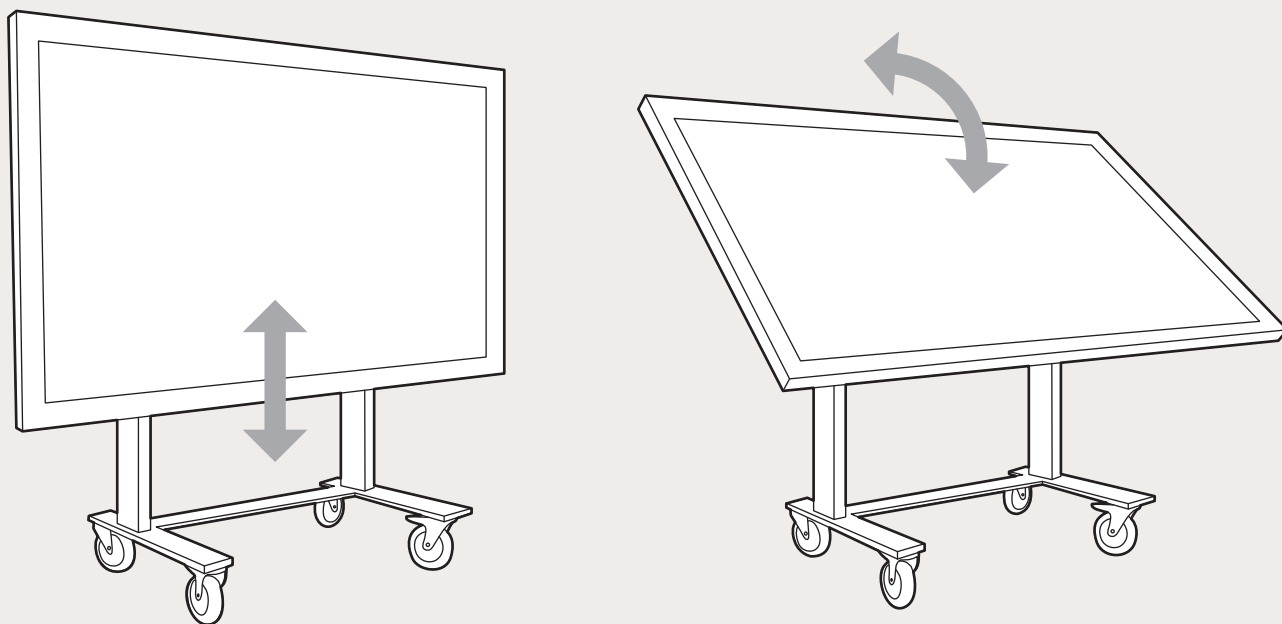

## Solution Overview

Column for lifting: TL5, TL6

Actuator for tilting (optional): TA16

Control Box: TC11, TC15, TC16

Control: TH14, TH37, TDH3, TDH5, TFH8

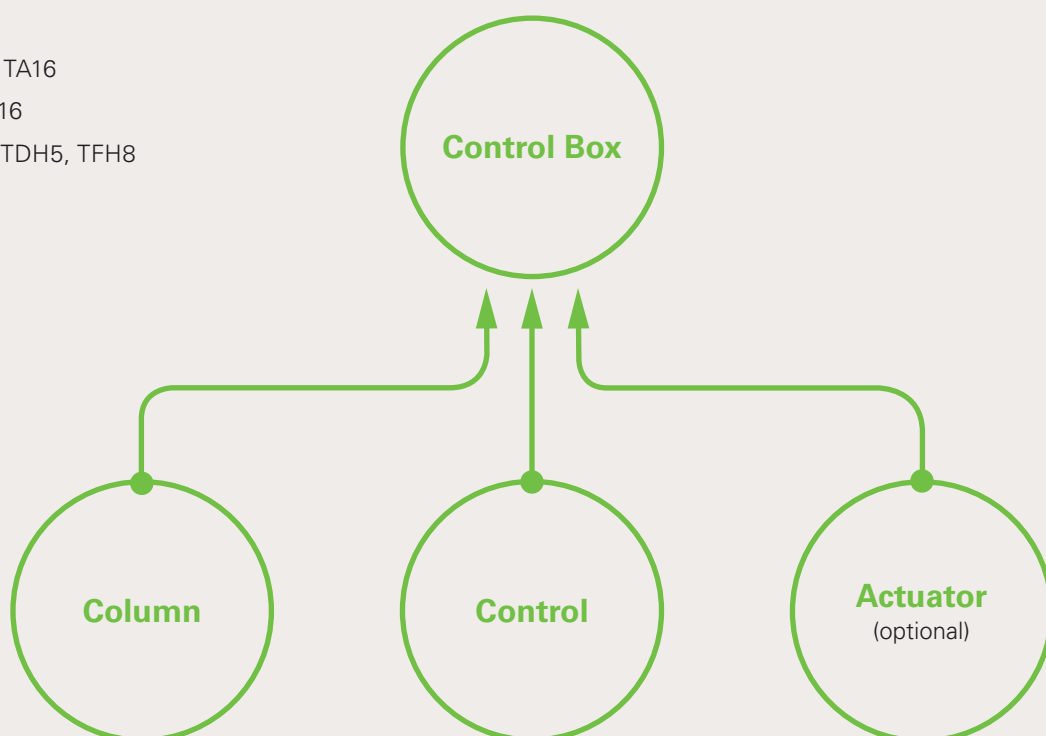

# Columns



## TL5 SERIES

**Maximum load**  
800N in push

**Maximum speed at no load**  
32mm/s

**Stroke**  
675mm

**Min. installation dimension**  
560mm

**Shape of outer tubes**  
Rectangular



## TL6 SERIES

**Maximum load**  
600N in push

**Maximum speed at no load**  
52mm/s

**Stroke**  
650mm

**Min. installation dimension**  
590mm

**Shape of outer tubes**  
Round

# Actuator

Optional

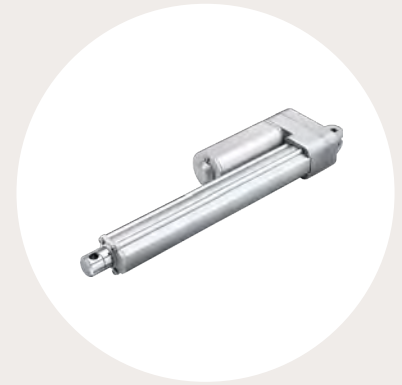

## TA16 SERIES

**Maximum load**  
2500N in pull/push

**Maximum speed at no load**  
16.6~18.8mm/s

**Stroke**  
675mm

**Min. installation dimension**  
stroke+112mm

# Control Boxes



## TC11 SERIES

Support single column

0.06W standby power consumption

Memory functions for column height

Soft stop function

Over current protection



## TC15 SERIES

Support two columns

0.06W standby power consumption

Memory functions for column height

Soft stop function

Over current protection



## TC16 SERIES

Support two columns and one tilt actuator

0.06W standby power consumption

Memory functions for column height

Soft stop function

Over current protection

# Controls



## TH14 SERIES

Maximum available buttons 2



## TH37 SERIES

Maximum available buttons 2



## TFH8 SERIES

Maximum available buttons 2



## TDH3 SERIES

Maximum available buttons 6

Have memory function up to 3 sets



## TDH5 SERIES

Maximum available buttons 6

Have memory function up to 4 sets

---

### Headquarters

TiMOTION Technology Co., Ltd.  
Tel 886 2 2219 6633  
Email sales@timotion.tw

### TiMOTION Kunshan

Tel 86 512 5526 0735  
Email sales@timotion.tw

### TiMOTION Japan

Tel 81 6 6763 1110  
Email sales@timotion.jp

### TiMOTION Korea

Tel 82 031 745 1060  
Email sales@timotion.co.kr

### TiMOTION Europe

Tel 33 (0)1 74 82 50 51  
Email sales@timotion.fr

### TiMOTION USA

Tel (855) 235 1424  
Email sales@timotionusa.com