

PC Series Clutch

PC-500

See page 230 for details on Drive Pin mountings.

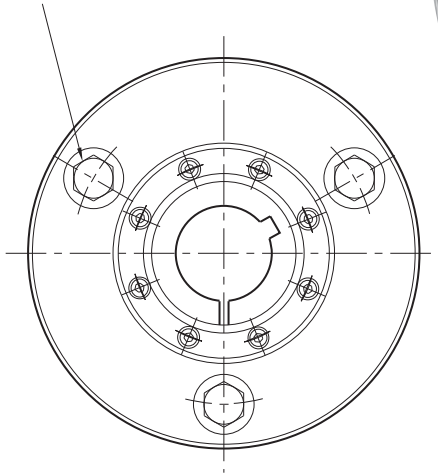
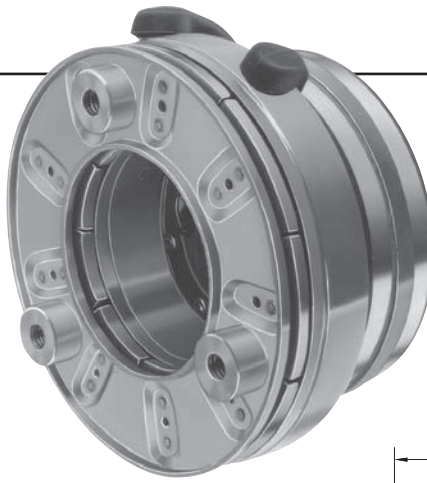

ARMATURE VIEW

1/2-14 NPSM Am. std. straight pipe tap.

See page 252 for details on Bushings.

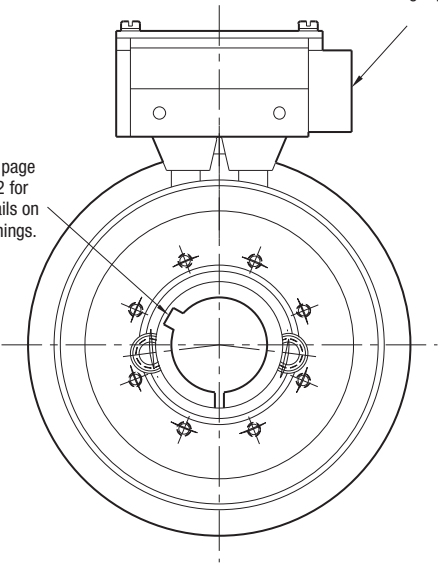

MAGNET VIEW

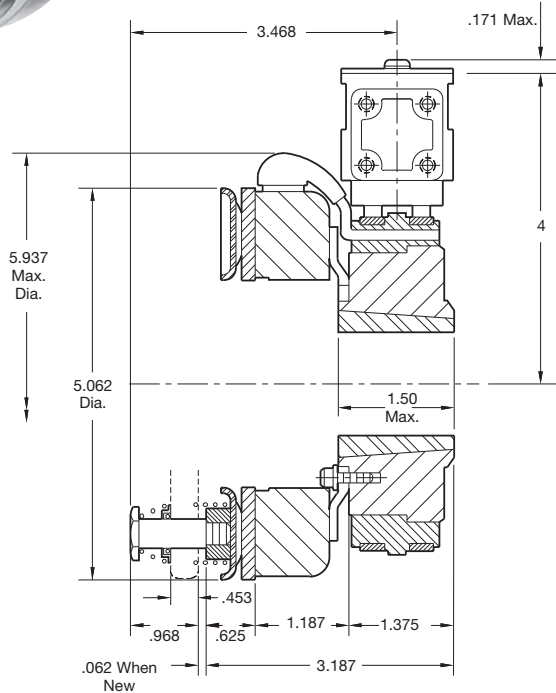

Shaft Size	.500 – 1.250
Static Torque	40 lb.ft.
Maximum Speed	5,400 rpm
Standard Voltage	D.C. 6, 24, 90

All dimensions are nominal unless otherwise noted.

Information on inertia and weights begins on page 239. Coil data is on pages 250 and 251.

Customer Shall Maintain:

1. Armature mounting to be concentric with magnet hub assembly within .006 T.I.R.



Drawing I-25716

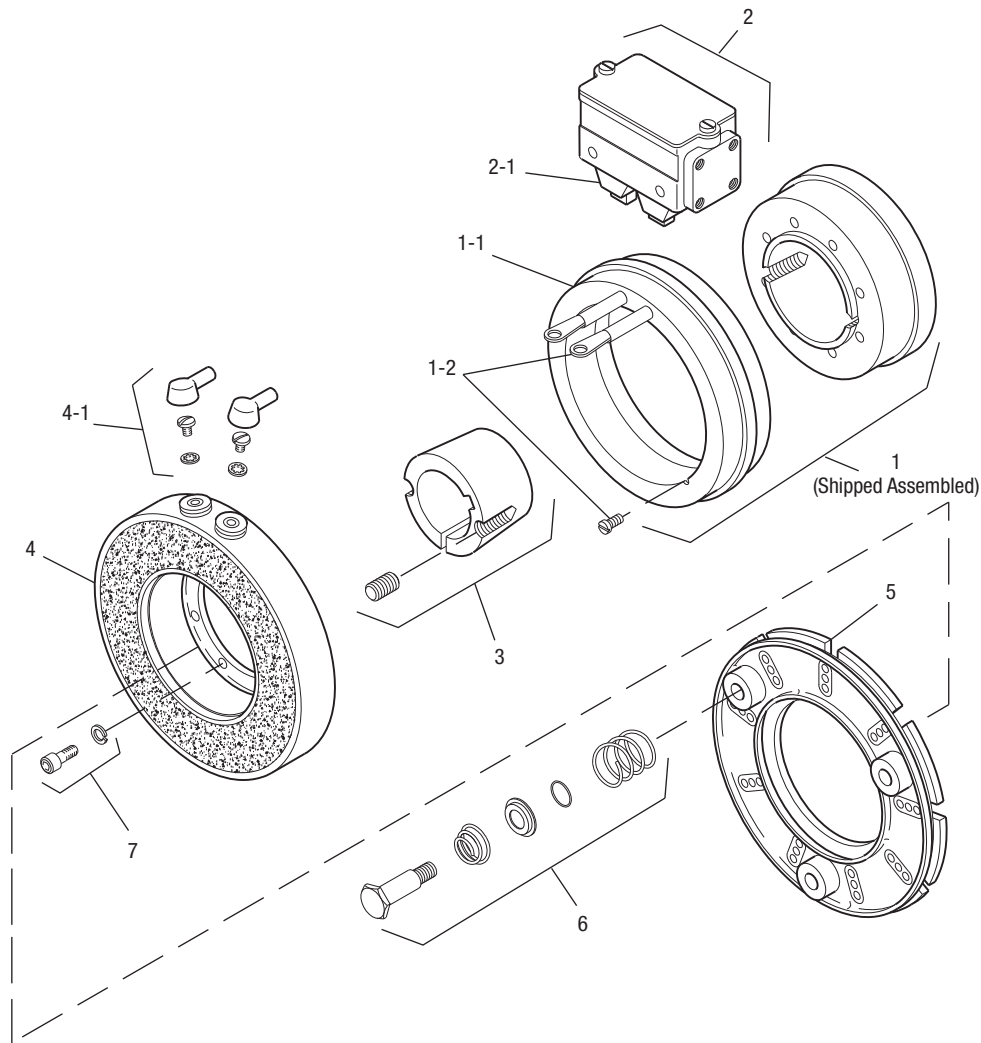

Item	Description	Part Number	Qty.
1	Magnet Hub	5300-541-001	1
1-1	Collector Ring	5300-749-001	1
1-2	Collector Ring Mounting Acc.	5300-101-002	1
2	Brushholder	5300-178-001	1
2-1	Brush	176-0001	4
3	Bushing*		1
	1/2" to 1-1/4" Bore	180-0116 to 180-0128	
4	Magnet		1
	6 Volt.	5300-631-002	
	24 Volt	5300-631-003	
	90 Volt	5300-631-005	
4-1	Terminal Accessory	5311-101-001	1
5	Armature	5300-111-002	1
6	Autogap Accessory	5200-101-009	3
7	Mounting Accessory	5102-101-001	2

How to Order:

1. Specify Bore Size for Item 3.
2. Specify Voltage for Item 4.
3. See Controls Section.

Example:

PC-500 Clutch per I-25716 - 90 Volt, 3/4" Bore

These units, when used in conjunction with the correct Warner Electric conduit box, meet the standards set of UL508 and are listed under guide card #NMTR2, file #59164.

These units are CSA certified under file #LR11543.

*See page 252 for specific part numbers.

Refer to Service Manual P-0203-WE

PC Series Clutch

PC-825 Normal Duty

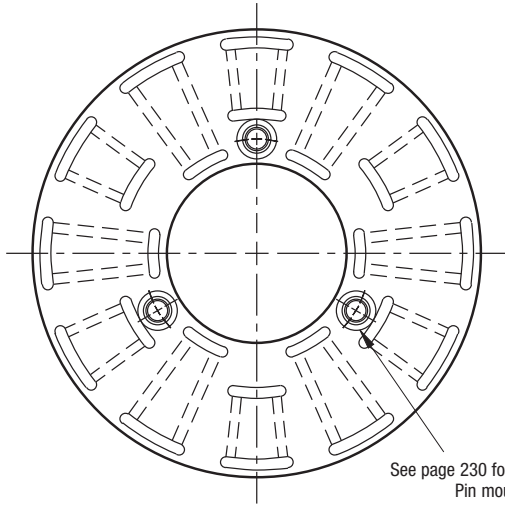

ARMATURE VIEW

See page 230 for details on Drive Pin mountings.

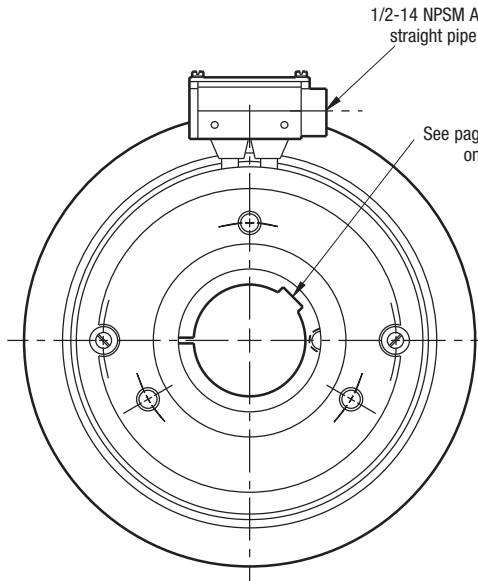

COLLECTOR RING VIEW

1/2-14 NPSM Am. std. straight pipe tap.

See page 252 for details on Bushings.

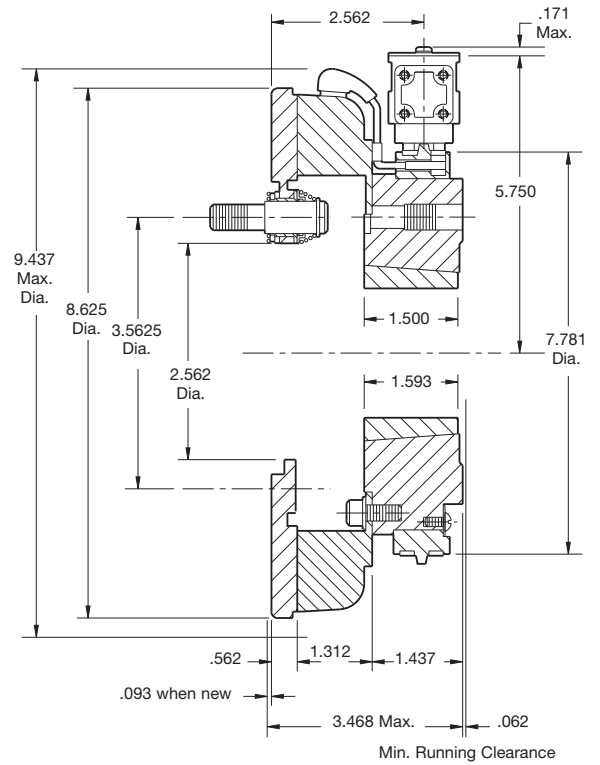

Shaft Size	.500 – 1.625
Static Torque	125 lb.ft.
Maximum Speed	4,000 rpm
Standard Voltage	D.C. 6, 24, 90

All dimensions are nominal unless otherwise noted.

Information on inertia and weights begins on page 239. Coil data is on pages 250 and 251.



Drawing I-25562

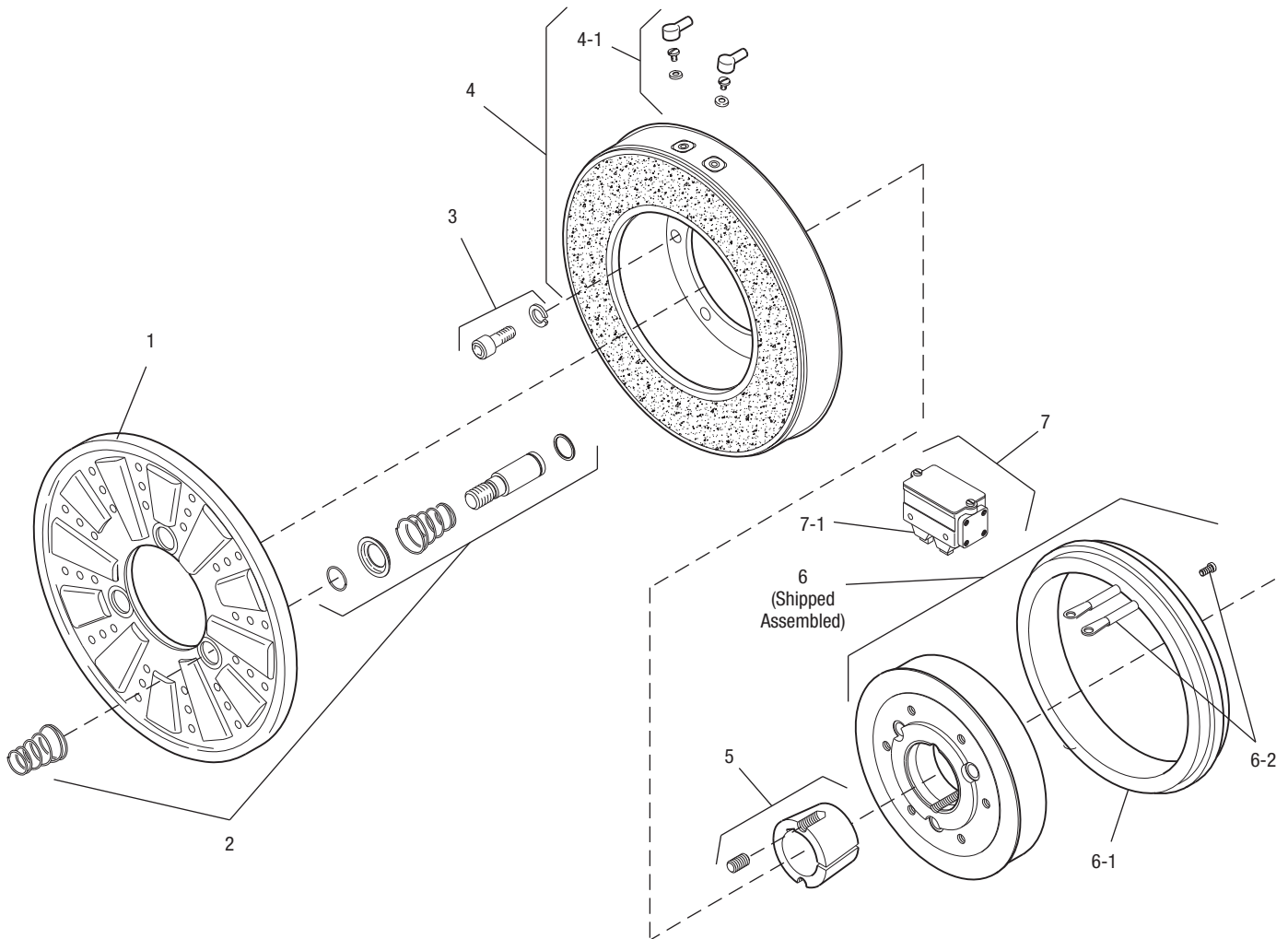

Item	Description	Part Number	Qty.
1	Armature	5301-111-018	1
2	Autogap Accessory	5201-101-008	3
3	Mounting Accessory	5321-101-001	1
4	Magnet		1
	6 Volt	5301-631-002	
	24 Volt	5301-631-004	
	90 Volt	5301-631-005	
	†90 Volt LK Facing	5301-631-011	
4-1	Terminal Accessory	5311-101-001	1
5	Bushing*		1
	1/2" to 1-5/8" Bore	180-0131 to 180-0149	
6	Magnet Hub		1
	Left Hand (shown)	5301-541-001	
	Right Hand	5301-541-002	
6-1	Collector Ring	5301-749-001	1
6-2	Collector Ring Accessory	5301-101-002	1
7	Brushholder	5300-178-001	1
7-1	Brush	176-0001	4

How to Order:

1. Specify Voltage for Item 4.
2. Specify Bore Size for Item 5.
3. Specify left hand or right hand hub for Item 6. (Bushing enters from magnet side for L.H. hub and from hub side for R.H.)
4. See Controls Section.

Example:

PC-825 Clutch per I-25562 - 90 Volt, L.H. hub, 1" Bore

These units meet the standards of UL508 and are listed under guide card #NMTR2, file #59164.

These units are CSA certified under file #LR11543.

*See page 252 for specific part numbers.

Refer to Service Manual P-0206-WE

†Optional LK facing available. For more information, see page 232.

PC Series Clutch

PC-825 Heavy Duty

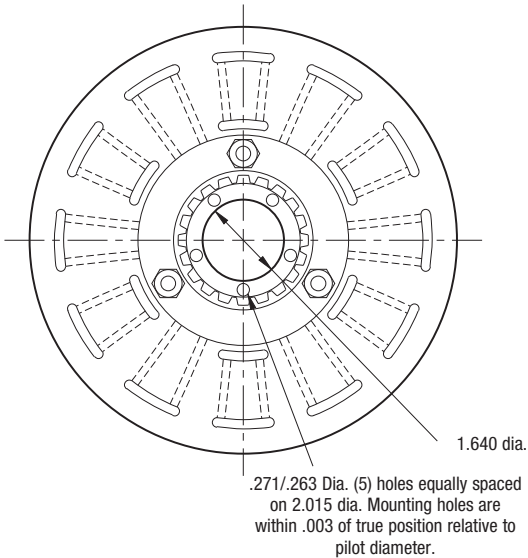

ARMATURE VIEW

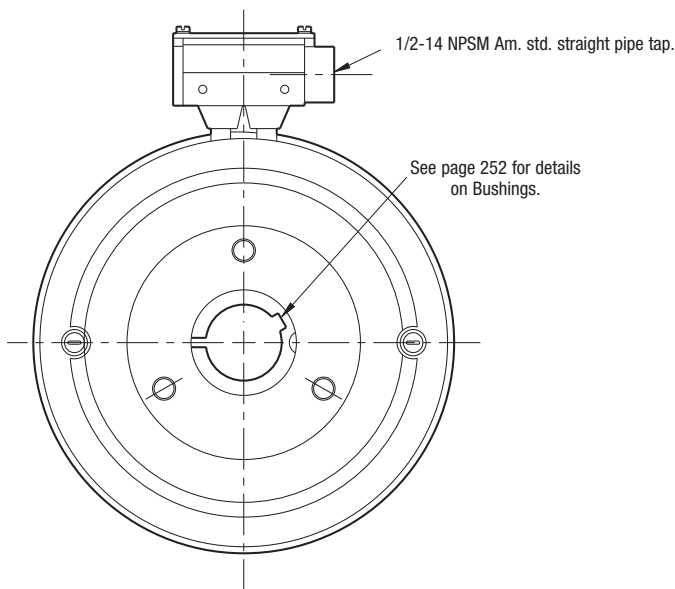

COLLECTOR RING VIEW

Customer Shall Maintain:

1. Splined hub pilot diameter to be concentric with splined armature center of rotation within .010 T.I.R.
2. Magnet hub shaft to be concentric with splined armature center of rotation within .006 T.I.R.

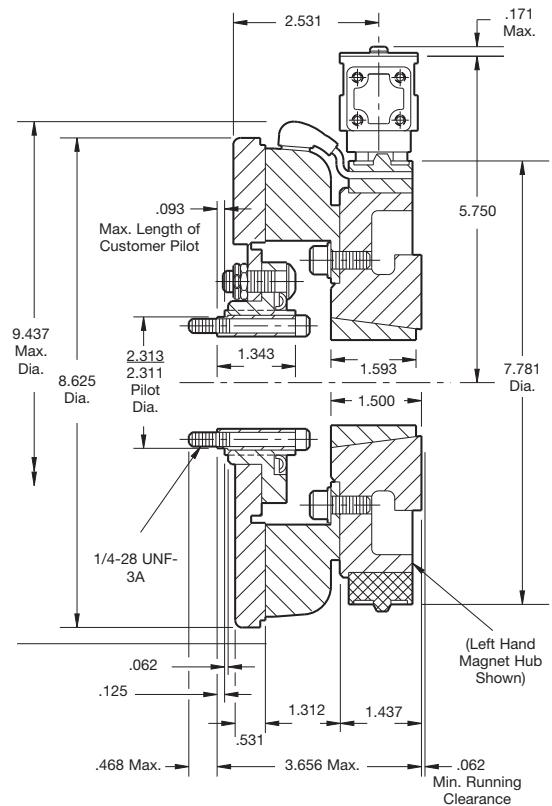

Shaft Size	.500 – 1.625
Static Torque	125 lb.ft.
Maximum Speed	4,000 rpm
Standard Voltage	D.C. 6, 24, 90

All dimensions are nominal unless otherwise noted.

Information on inertia and weights begins on page 239. Coil data is on pages 250 and 251.



Drawing I-25563

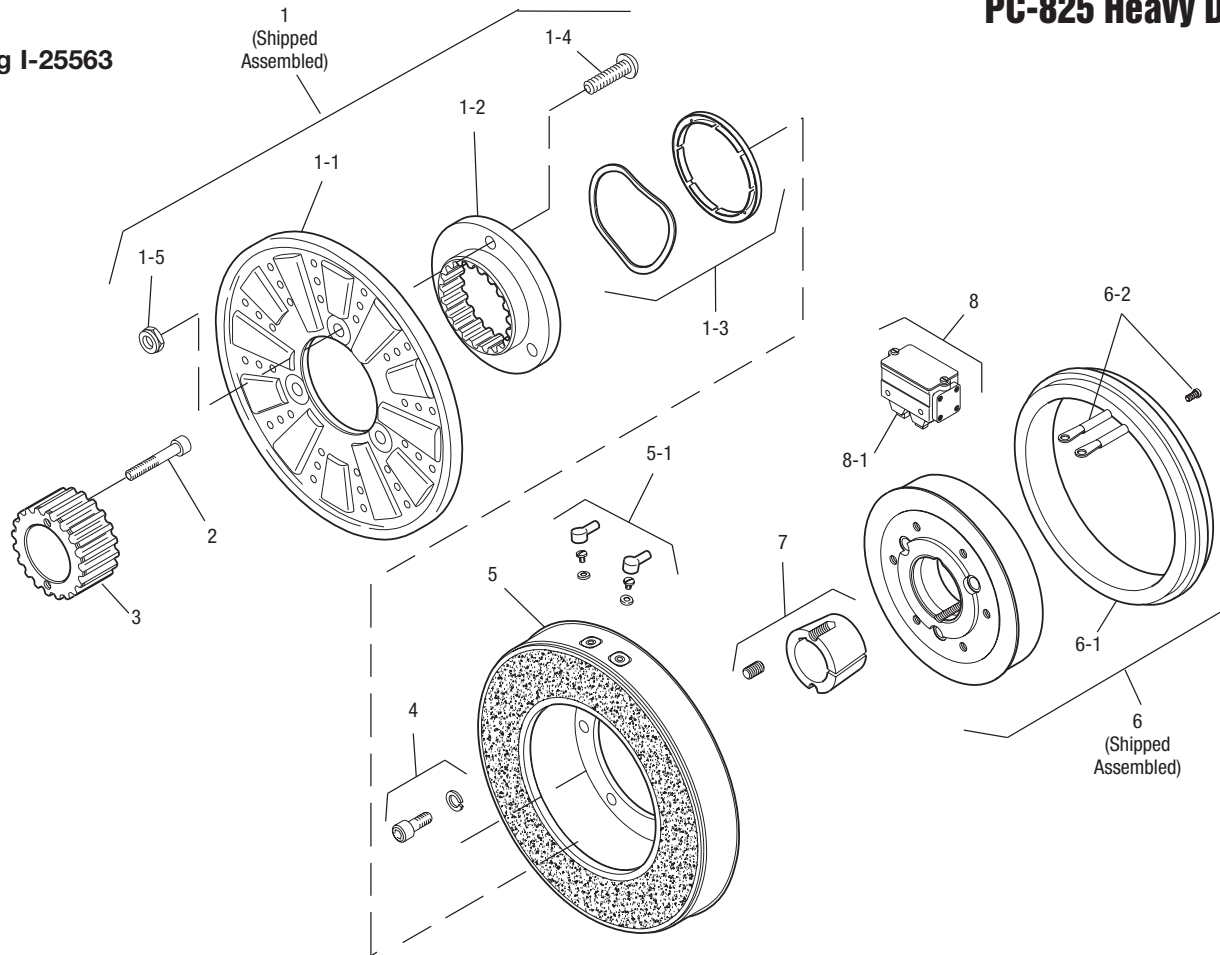

Item	Description	Part Number	Qty.
1	Armature & Splined Adapter Assembly	5321-111-001	1
1-1	Armature	5321-111-022	1
1-2	Splined Armature Adapter	104-0008	1
1-3	Autogap Accessory	5321-101-006	1
	Autogap Spring	808-0054	1
	Retainer Ring	748-0373	1
1-4	Button Head Screw	797-0272	3
1-5	Locknut	661-0004	3
2	Mounting Accessory	5201-101-001	1
3	Splined Hub	540-0146	1
4	Mounting Accessory	5321-101-001	1
5	Magnet		1
	6 Volt	5301-631-002	
	24 Volt	5301-631-004	
	90 Volt	5301-631-005	
	†90 Volt LK Facing	5301-631-011	
5-1	Terminal Accessory	5311-101-001	1
6	Magnet Hub Assembly		1
	Right Hand	5301-541-002	
	Left Hand (shown)	5301-541-001	

Item	Description	Part Number	Qty.
6-1	Collector Ring	5301-749-001	1
6-2	Collector Ring Accessory	5301-101-002	1
7	Bushing, Taperlock*	180-0131 to 180-0149	1
8	Brushholder	5300-178-001	1
8-1	Brush	176-0001	4

How to Order:

1. Specify Voltage for Item 5.
2. Specify Bore Size for Item 7.
3. Specify left hand or right hand hub for Item 6.
4. See Controls Section.

Example:

PC-825 Clutch per I-25563 - 90 Volt, L.H. hub, 1" Bore
 These units meet the standards of UL508 and are listed under guide card #NMTR2, file #59164. These units are CSA certified under file #LR11543

*See page 252 for specific part numbers.

Refer to Service Manual P-0206-WE

†Optional LK facing available. For more information, see page 232.

PC Series Clutch

PC-1000 Normal Duty

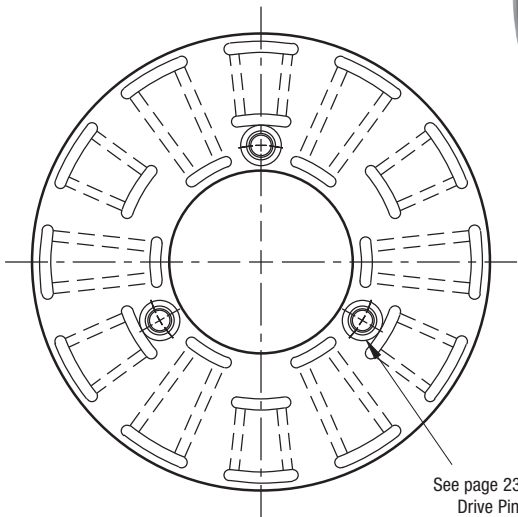
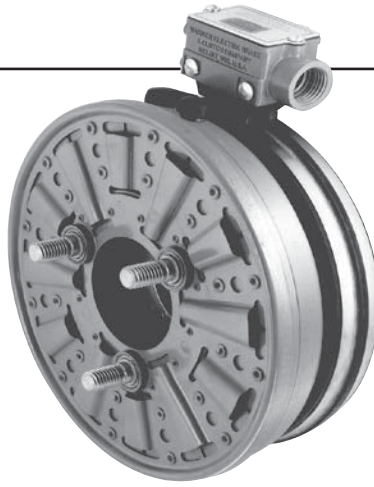

See page 230 for details on Drive Pin mountings.

ARMATURE VIEW

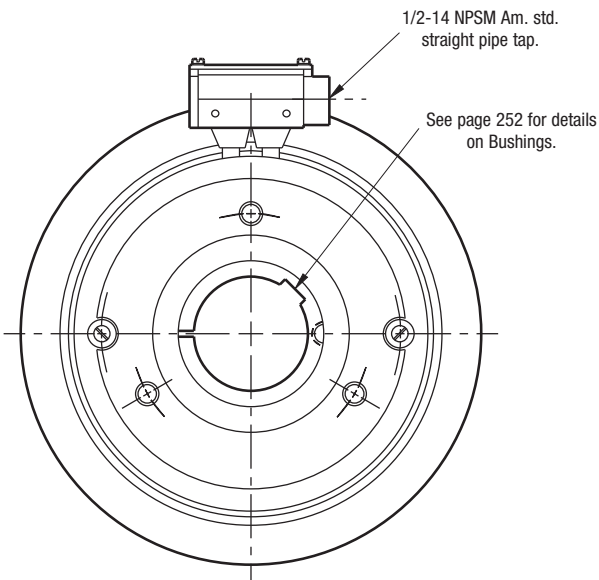

See page 252 for details on Bushings.

COLLECTOR RING VIEW

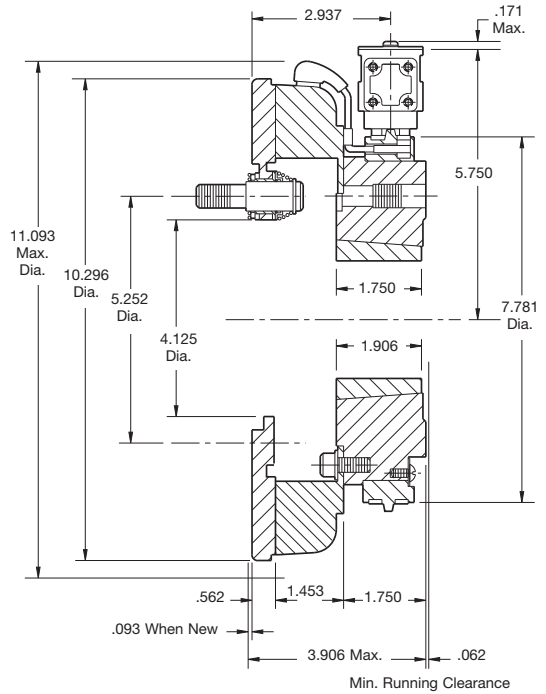

Shaft Size	.500 – 2.500
Static Torque	240 lb.ft.
Maximum Speed	3,600 rpm
Standard Voltage	D.C. 6, 24, 90

All dimensions are nominal unless otherwise noted.

Information on inertia and weights begins on page 239. Coil data is on pages 250 and 251.



Drawing I-25582

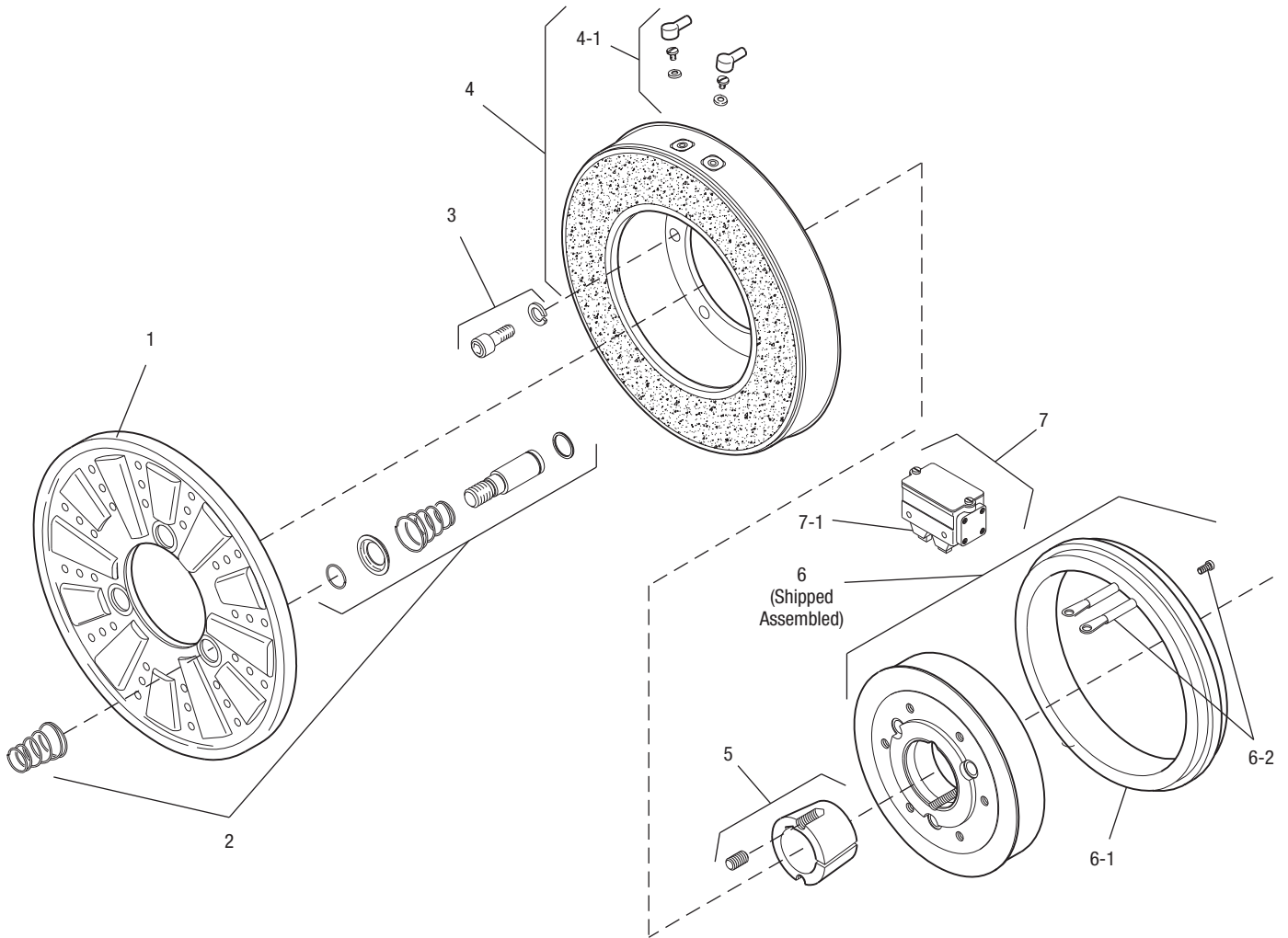

Item	Description	Part Number	Qty.
1	Armature	5302-111-013	1
2	Autogap Accessory	5201-101-008	3
3	Mounting Accessory	5321-101-001	1
4	Magnet		1
	6 Volt	5302-631-003	
	24 Volt	5302-631-014	
	90 Volt	5302-631-005	
	†90 Volt LK Facing	5302-631-001	
4-1	Terminal Accessory	5311-101-001	1
5	Bushing*		1
	1/2" to 2-1/2" Bore	180-0185 to 180-0217	
6	Magnet Hub		1
	Left Hand (shown)	5302-541-001	
	Right Hand	5302-541-002	
6-1	Collector Ring	5301-749-001	1
6-2	Collector Ring Accessory	5302-101-002	1
7	Brushholder	5300-178-001	1
7-1	Brush	176-0001	4

How to Order:

1. Specify Voltage for Item 4.
2. Specify Bore Size for Item 5.
3. Specify left hand or right hand hub for Item 6. (Bushing enters from magnet side for L.H. hub and from hub side for R.H.)
4. See Controls Section.

Example:

PC-1000 Clutch per I-25582 - 90 Volt, L.H. hub, 1" Bore
 These units meet the standards of UL508 and are listed under guide card #NMTR2, file #59164.
 These units are CSA certified under file #LR11543.

*See page 252 for specific part numbers.

Refer to Service Manual P-0206-WE

†Optional LK facing available. For more information, see page 232.

PC Series Clutch

PC-1000 Heavy Duty

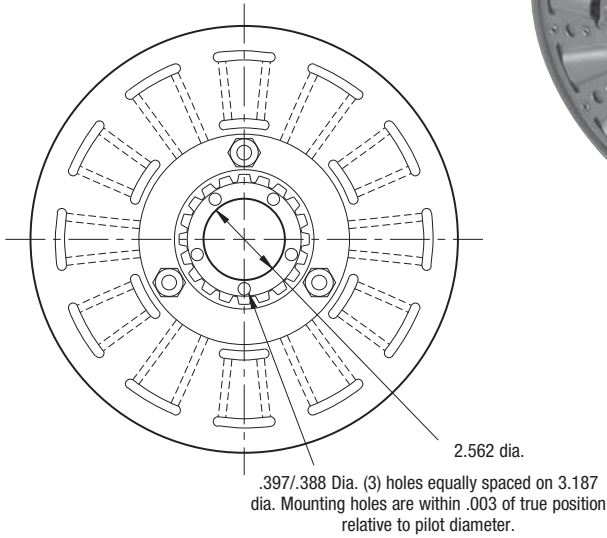

ARMATURE VIEW

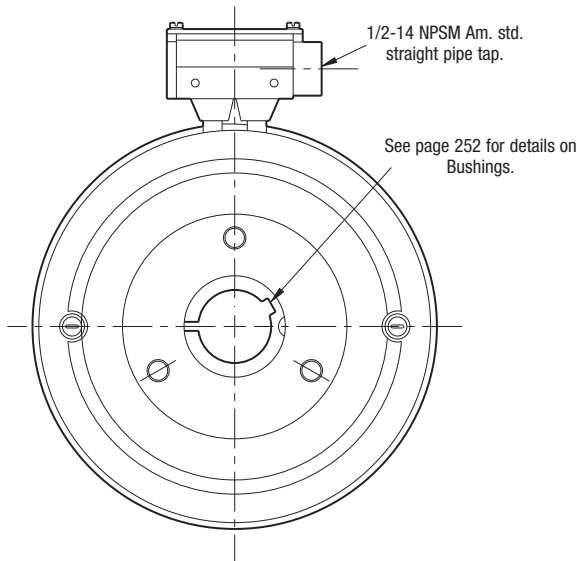

COLLECTOR RING VIEW

Customer Shall Maintain:

1. Splined hub pilot diameter to be concentric with splined armature center of rotation within .010 T.I.R.
2. Magnet hub shaft to be concentric with splined armature center of rotation within .006 T.I.R.

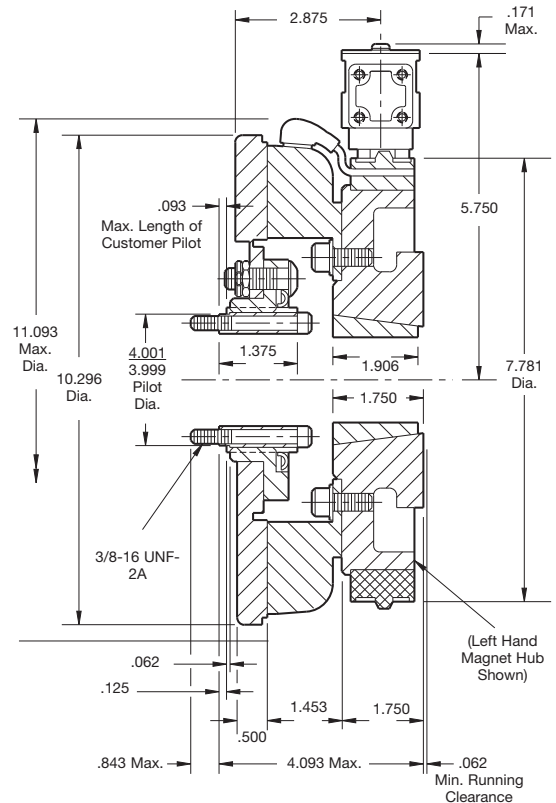

Shaft Size	.500 – 2.500
Static Torque	240 lb.ft.
Maximum Speed	3,600 rpm
Standard Voltage	D.C. 6, 24, 90

All dimensions are nominal unless otherwise noted.

Information on inertia and weights begins on page 239. Coil data is on pages 250 and 251.



Drawing I-25583

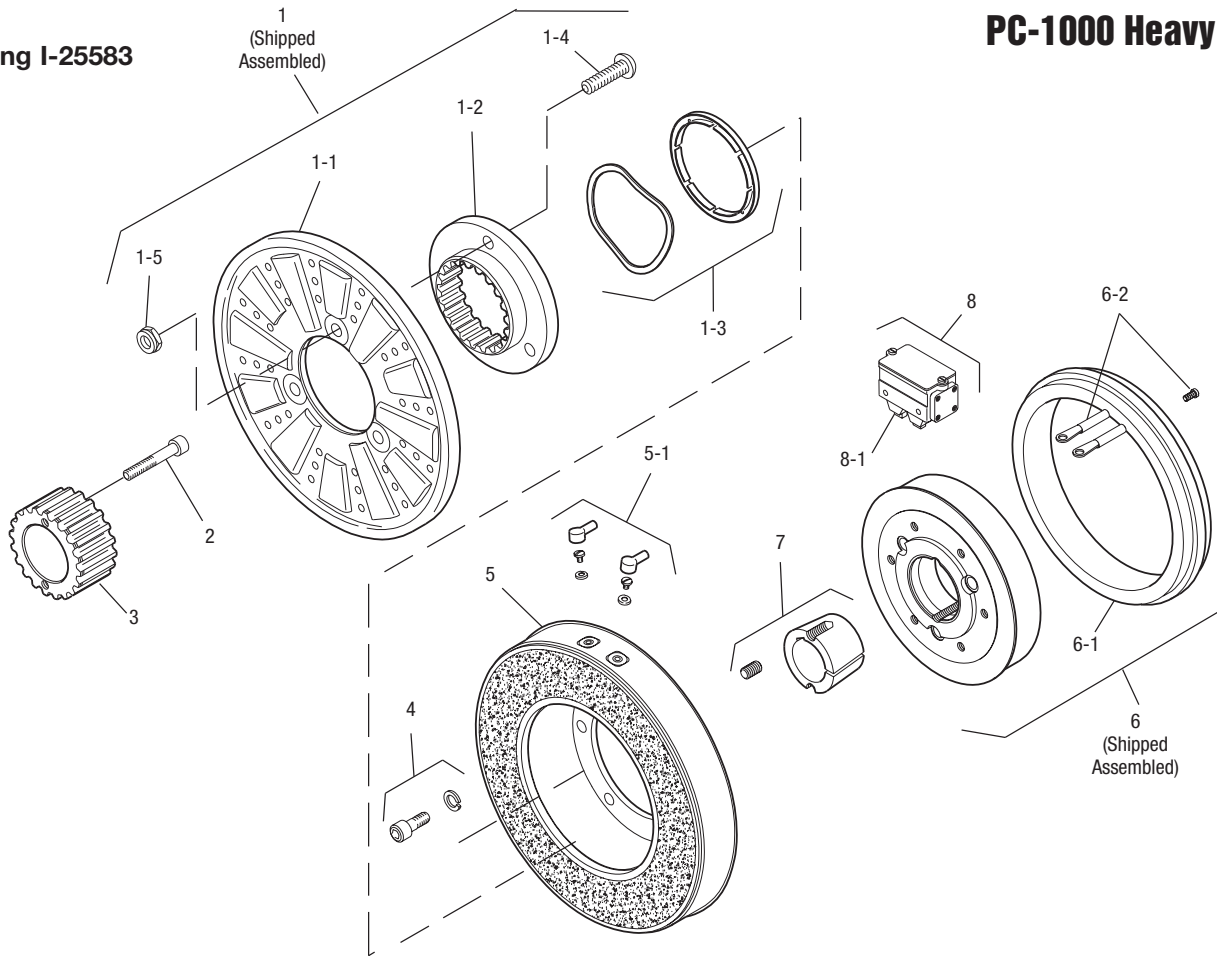

Item	Description	Part Number	Qty.
1	Armature & Splined Adapter Assembly	5322-111-002	1
1-1	Armature	5322-111-036	1
1-2	Splined Armature Adapter	104-0009	1
1-3	Autogap Accessory	5322-101-004	1
	Autogap Spring	808-0061	1
	Retainer Ring	748-0374	1
1-4	Button Head Screw	797-0272	3
1-5	Locknut	661-0004	3
2	Mounting Accessory	5202-101-001	1
3	Splined Hub	540-0147	1
4	Mounting Accessory	5321-101-001	1
5	Magnet		1
	6 Volt	5302-631-003	
	24 Volt	5302-631-014	
	90 Volt	5302-631-005	
	†90 Volt LK Facing	5302-631-001	
5-1	Terminal Accessory	5311-101-001	1
6	Magnet Hub Assembly		1
	Right Hand	5302-541-002	
	Left Hand (shown)	5302-541-001	

Item	Description	Part Number	Qty.
6-1	Collector Ring	5301-749-001	1
6-2	Collector Ring Accessory	5302-101-002	1
7	Bushing, Taperlock*	180-0185 to 180-0217	1
8	Brushholder	5300-178-001	1
8-1	Brush	176-0001	4

How to Order:

1. Specify Voltage for Item 5.
2. Specify Bore Size for Item 7.
3. Specify left hand or right hand hub for Item 6.
4. See Controls Section.

Example:

PC-1000 Clutch per I-25583 - 90 Volt, L.H. hub, 1" Bore

These units meet the standards of UL508 and are listed under guide card #NMTR2, file #59164.

These units are CSA certified under file #LR11543

*See page 252 for specific part numbers.

Refer to Service Manual P-0206-WE

†Optional LK facing available. For more information, see page 232.

PC Series Clutch

PC-1225 Normal Duty

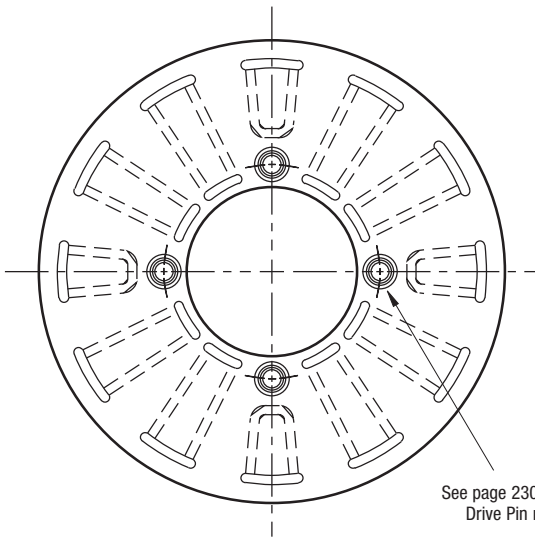

ARMATURE VIEW

See page 230 for details on Drive Pin mountings.

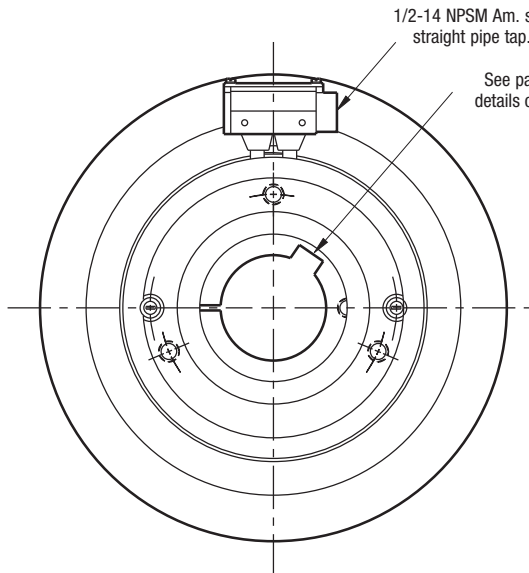

COLLECTOR RING VIEW

1/2-14 NPSM Am. std. straight pipe tap.

See page 252 for details on Bushings.

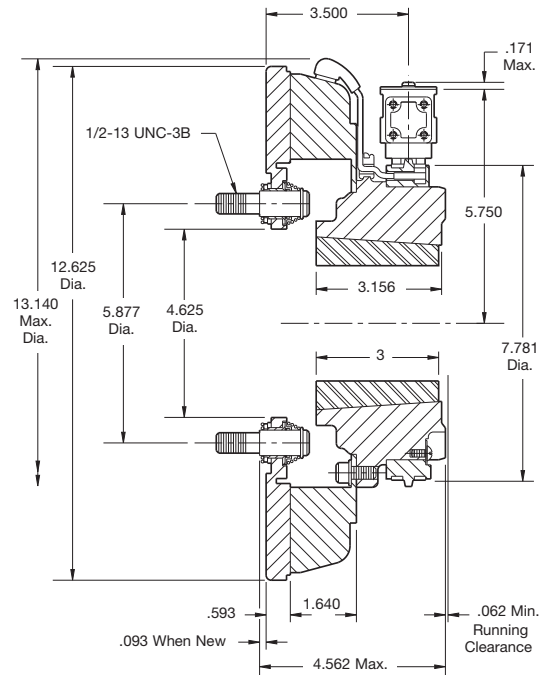

Shaft Size	.937 – 3.000
Static Torque	465 lb.ft.
Maximum Speed	3,000 rpm
Standard Voltage	D.C. 6, 24, 90

All dimensions are nominal unless otherwise noted.

Information on inertia and weights begins on page 239. Coil data is on pages 250 and 251.



Drawing I-25602

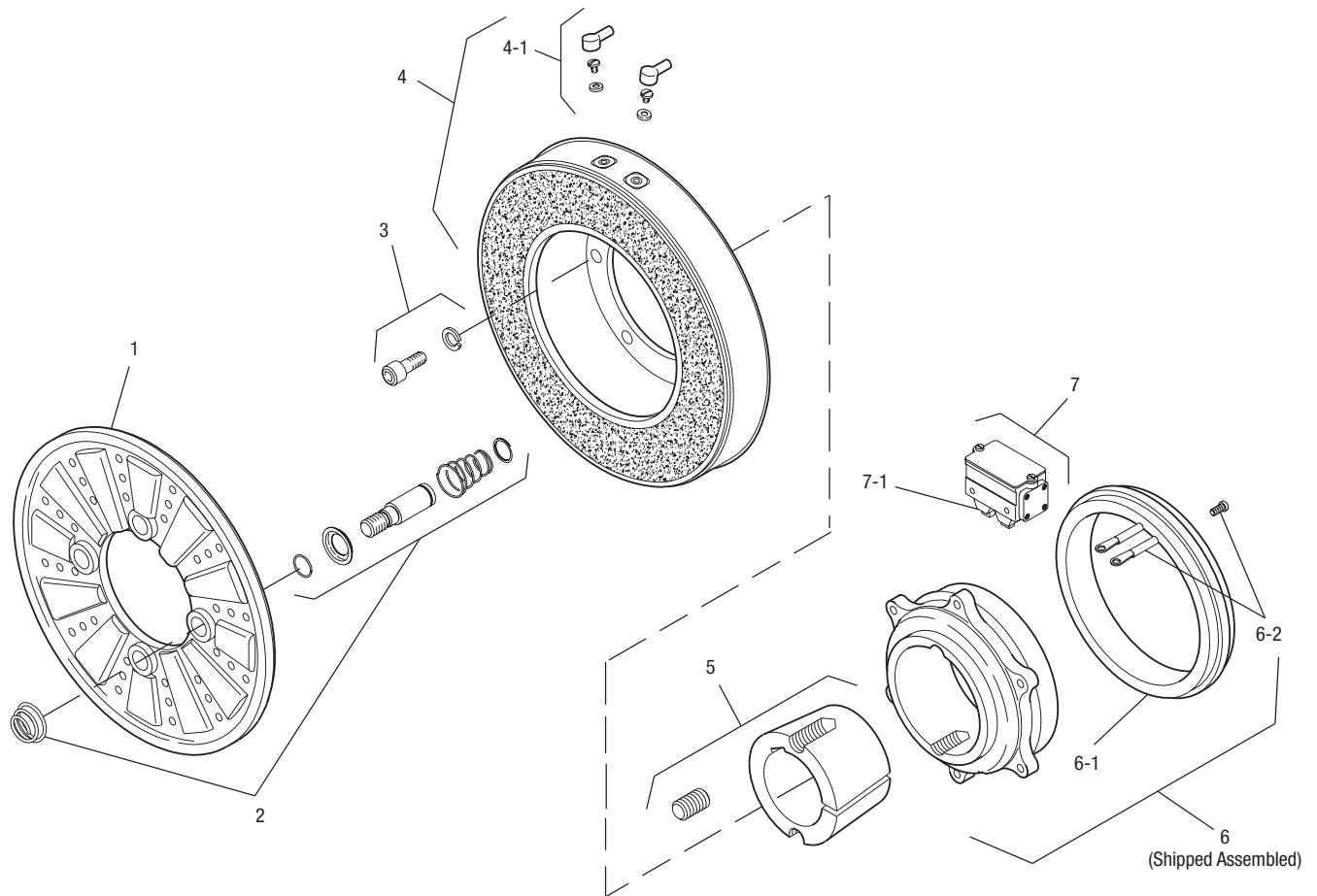

Item	Description	Part Number	Qty.
1	Armature	5303-111-009	1
2	Autogap Accessory	5201-101-008	4
3	Mounting Accessory	5321-101-001	1
4	Magnet		1
	6 Volt	5303-631-005	
	24 Volt	5303-631-007	
	90 Volt	5303-631-008	
	†90 Volt LK Facing	5303-631-001	
4-1	Terminal Accessory	5311-101-001	1
5	Bushing*		1
	15/16" to 3" Bore	180-0262 to 180-0295	
6	Magnet Hub		1
	Left Hand (shown)	5303-541-001	
	Right Hand	5303-541-002	
6-1	Collector Ring	5301-749-001	1
6-2	Collector Ring Accessory	5303-101-004	1

Item	Description	Part Number	Qty.
7	Brushholder	5300-178-001	1
7-1	Brush	176-0001	4

How to Order:

1. Specify Voltage for Item 4.
2. Specify Bore Size for Item 5.
3. Specify left hand or right hand hub for Item 6. (Bushing enters from magnet side for L.H. hub and from hub side for R.H.)
4. See Controls Section.

Example:

PC-1225 Clutch per I-25602 - 90 Volt, L.H. hub, 1" Bore

These units meet standards set forth in UL508 and are listed under guide card #NMTR2, file #59164.

These units are CSA certified under file #LR11543

*See page 252 for specific part numbers.

Refer to Service Manual P-0207-WE

†Optional LK facing available. For more information, see page 232.

PC Series Clutch

PC-1225 Heavy Duty

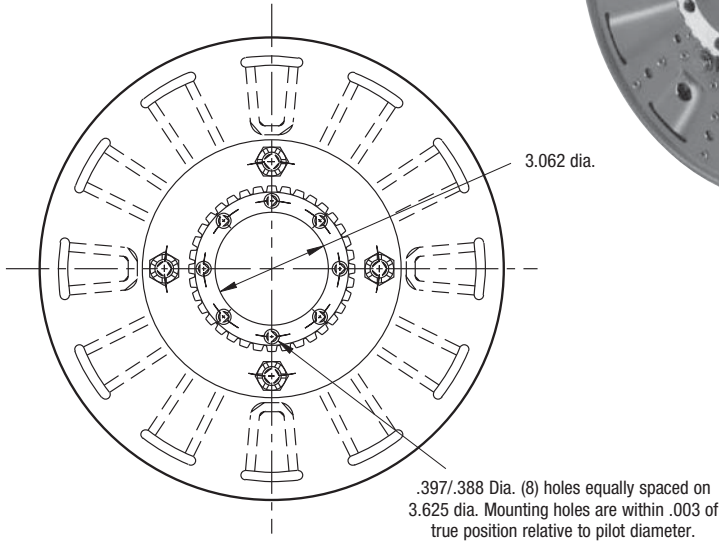
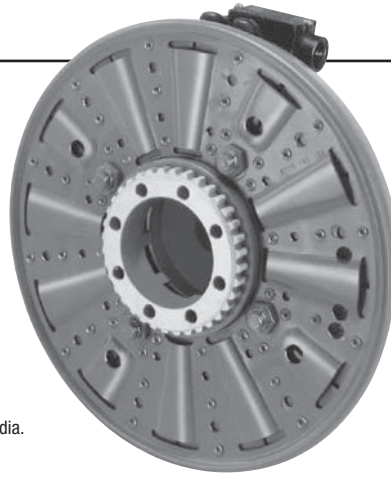

ARMATURE VIEW

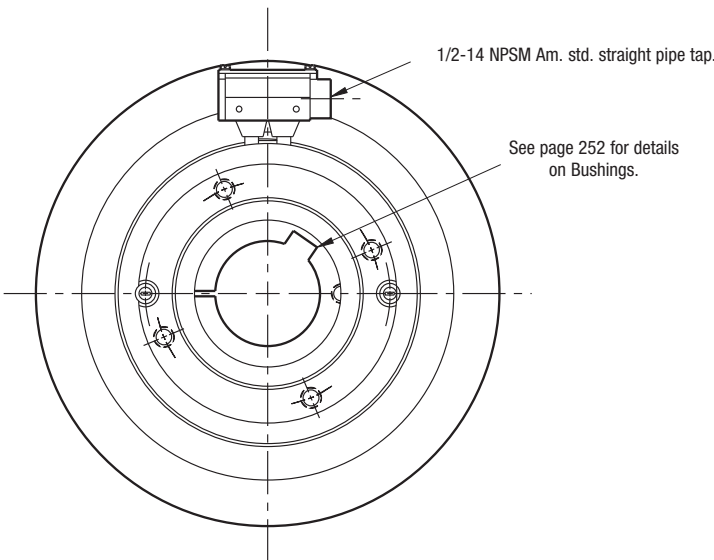

COLLECTOR RING VIEW

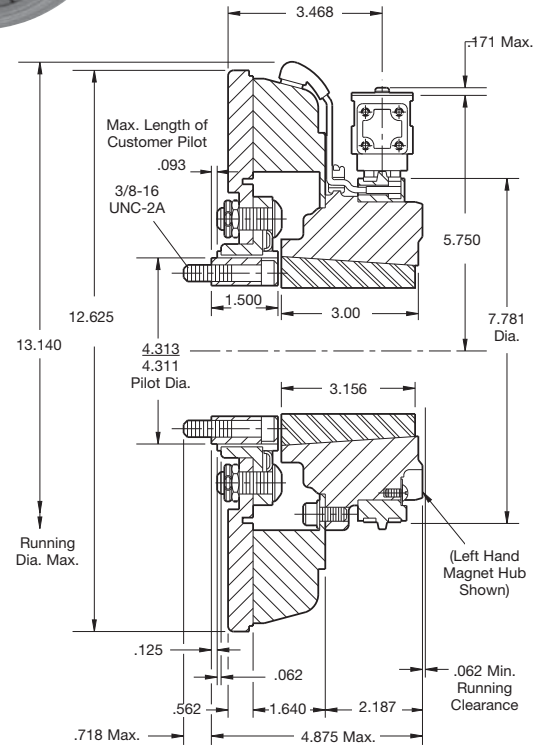

Shaft Size	.937 – 3.000
Static Torque	465 lb.ft.
Maximum Speed	3,000 rpm
Standard Voltage	D.C. 6, 24, 90

All dimensions are nominal unless otherwise noted.

Information on inertia and weights begins on page 239. Coil data is on pages 250 and 251.

Customer Shall Maintain:

1. Splined hub pilot diameter to be concentric with splined armature center of rotation within .010 T.I.R.



PC-1225 Heavy Duty

Drawing I-25603

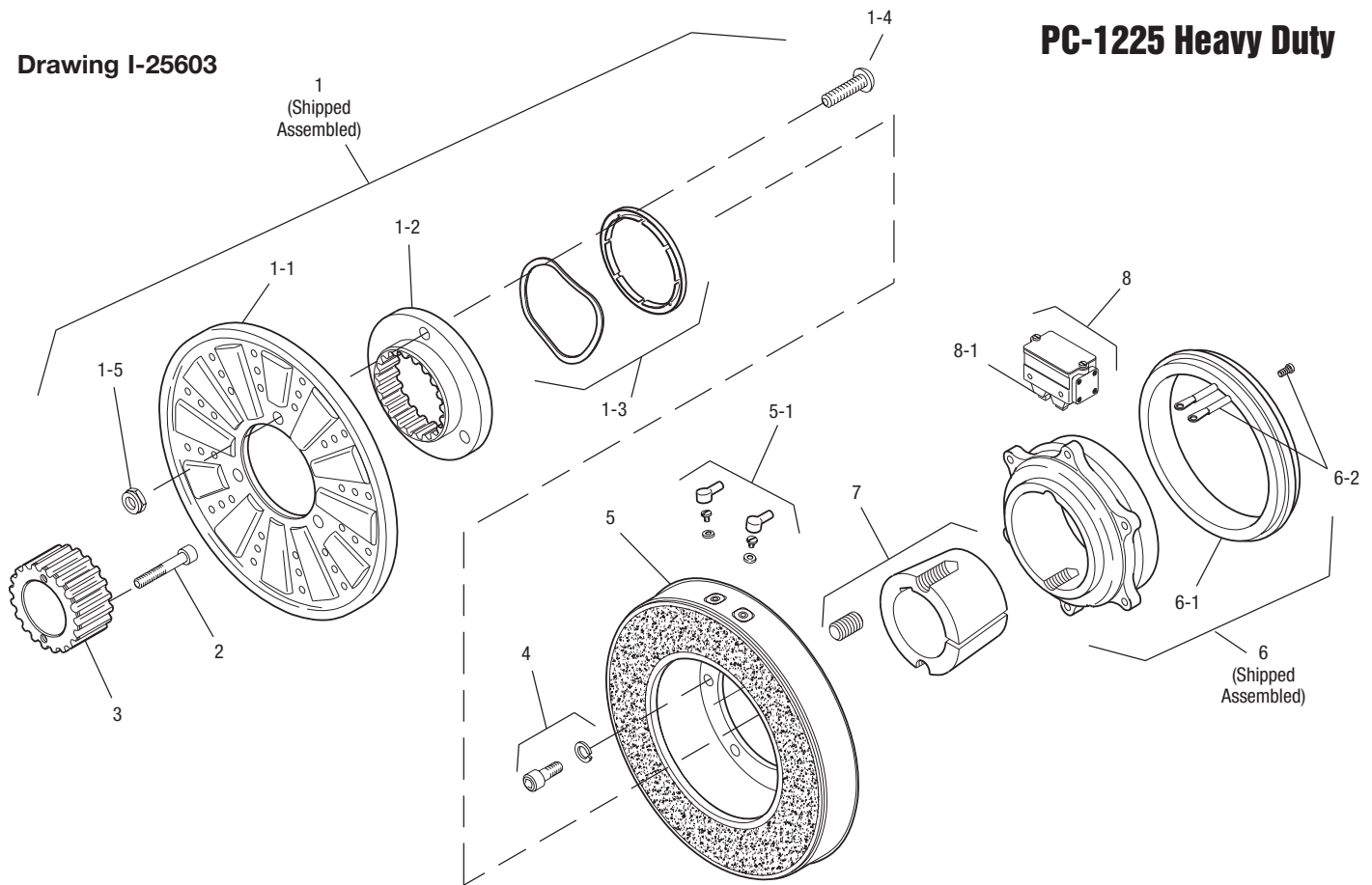

Item	Description	Part Number	Qty.
1	Armature & Splined Adapter Assembly	5323-111-001	1
1-1	Armature	5323-111-034	1
1-2	Splined Armature Adapter	104-0010	1
1-3	Autogap Accessory	5323-101-002	1
	Autogap Spring	808-0044	1
	Retainer Ring	748-0370	1
1-4	Button Head Screw	797-0281	4
1-5	Locknut	661-0005	4
2	Mounting Accessory	5202-101-001	3
3	Splined Hub	540-0148	1
4	Mounting Accessory	5321-101-001	1
5	Magnet		1
	6 Volt	5303-631-005	
	24 Volt	5303-631-007	
	90 Volt	5303-631-008	
	†90 Volt LK Facing	5303-631-001	
5-1	Terminal Accessory	5311-101-001	
6	Magnet Hub Assembly		1
	Right Hand	5303-541-002	
	Left Hand (shown)	5303-541-001	

Item	Description	Part Number	Qty.
6-1	Collector Ring	5301-749-001	1
6-2	Collector Ring Accessory	5303-101-004	1
7	Bushing, Taperlock*	180-0262 to 180-0295	1
8	Brushholder	5300-178-001	1
8-1	Brush	176-0001	4

How to Order:

1. Specify Voltage for Item 5.
2. Specify Bore Size for Item 7.
3. Specify left hand or right hand hub for Item 6.
4. See Controls Section.

Example:

PC-1225 Clutch per I-25603 - 90 Volt, L.H. hub, 1" Bore

These units meet the standards of UL508 and are listed under guide card #NMTR2, file #59164.

These units are CSA certified under file #LR11543.

*See page 252 for specific part numbers.

Refer to Service Manual P-0206-WE

†Optional LK facing available. For more information, see page 232.

PC Series Clutch

PC-1525 Normal Duty

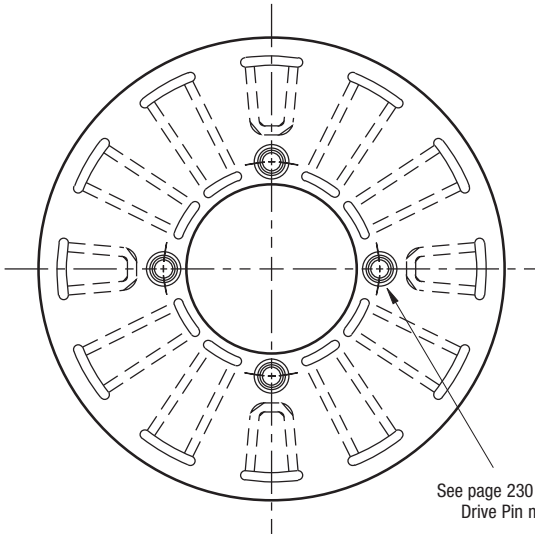

See page 230 for details on Drive Pin mountings.

ARMATURE VIEW

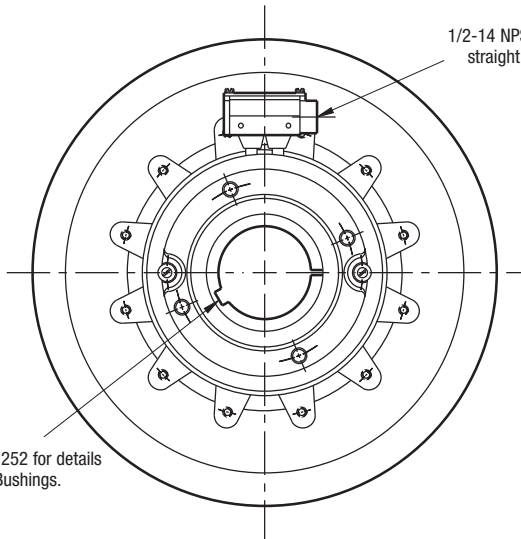

1/2-14 NPSM Am. std. straight pipe tap.

See page 252 for details on Bushings.

COLLECTOR RING VIEW

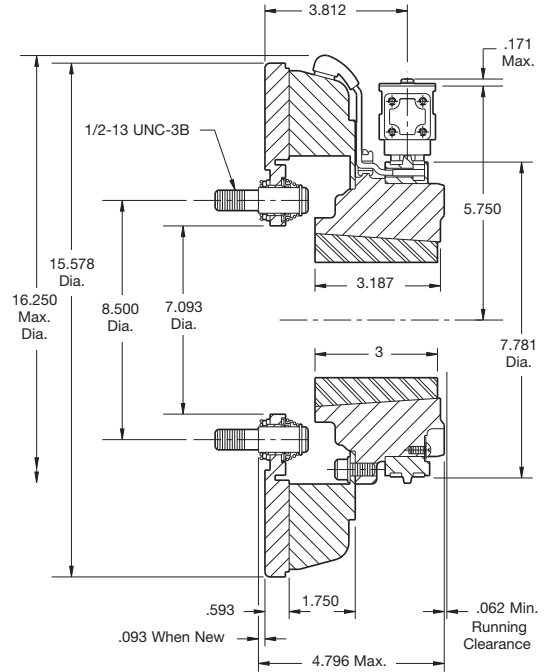

Shaft Size	.937 – 3.000
Static Torque	700 lb.ft.
Maximum Speed	2,000 rpm
Standard Voltage	D.C. 6, 24, 90

All dimensions are nominal unless otherwise noted.

Information on inertia and weights begins on page 239. Coil data is on pages 250 and 251.



Drawing I-25628

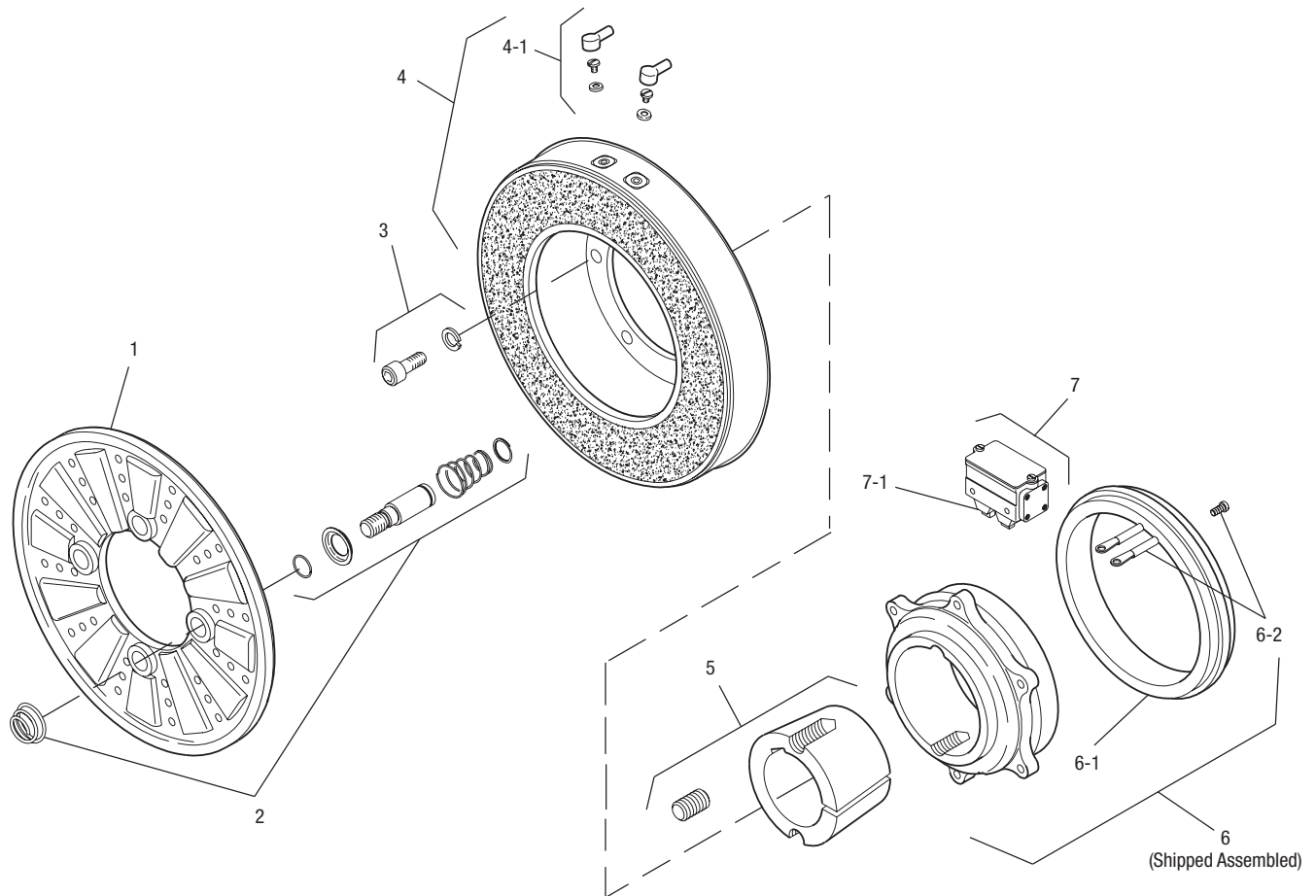

Item	Description	Part Number	Qty.
1	Armature	5304-111-004	1
2	Autogap Accessory	5201-101-008	4
3	Mounting Accessory	5321-101-001	2
4	Magnet		1
	6 Volt	5304-631-009	
	24 Volt	5304-631-011	
	90 Volt	5304-631-010	
	†90 Volt LK Facing	5304-631-002	
4-1	Terminal Accessory	5311-101-001	1
5	Bushing*		1
	15/16" to 3" Bore	180-0262 to 180-0295	
6	Magnet Hub		1
	Left Hand (shown)	5304-541-001	
	Right Hand	5304-541-002	
6-1	Collector Ring	5301-749-001	1
6-2	Collector Ring Accessory	5304-101-004	1

Item	Description	Part Number	Qty.
7	Brushholder	5300-178-001	1
7-1	Brush	176-0001	4

How to Order:

1. Specify Voltage for Item 4.
2. Specify Bore Size for Item 5.
3. Specify left hand or right hand hub for Item 6. (Bushing enters from magnet side for L.H. hub and from hub side for R.H.)
4. See Controls Section.

Example:

PC-1525 Clutch per I-25628 - 90 Volt, L.H. hub, 1" Bore

These units meet standards set forth in UL508 and are listed under guide card #NMTR2, file #59164.

These units are CSA certified under file #LR11543

*See page 252 for specific part numbers.

Refer to Service Manual P-0206-WE

†Optional LK facing available. For more information, see page 232.

PC Series Clutch

PC-1525 Heavy Duty

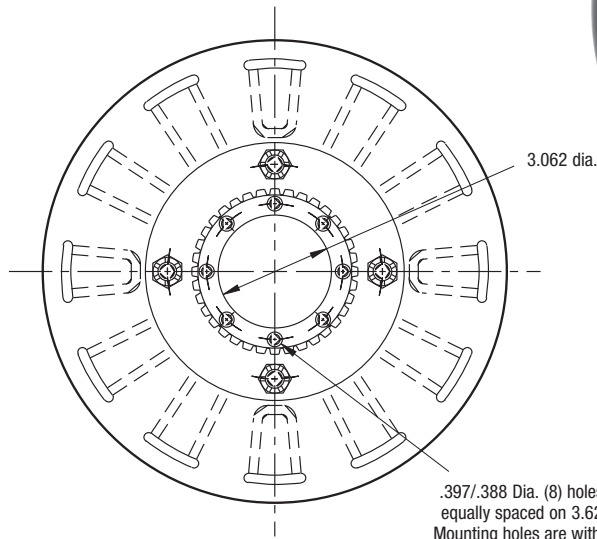
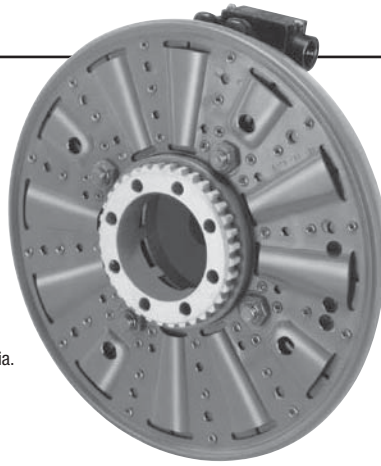

.397/.388 Dia. (8) holes (hub) equally spaced on 3.625 dia. Mounting holes are within .003 of true position relative to pilot diameter.

ARMATURE VIEW

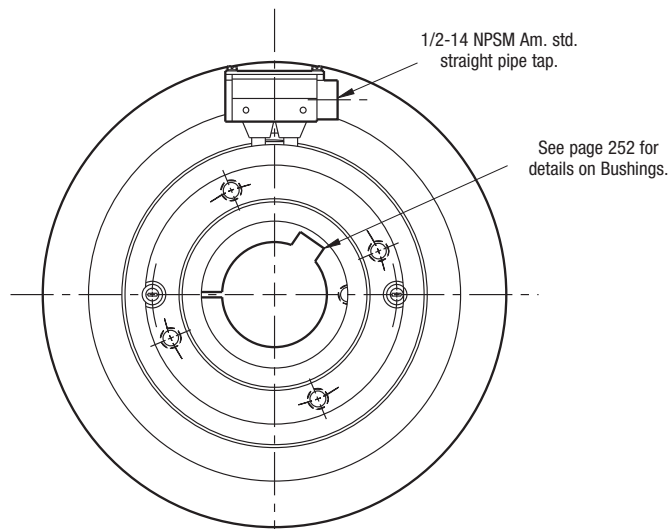

1/2-14 NPSM Am. std. straight pipe tap.

See page 252 for details on Bushings.

COLLECTOR RING VIEW

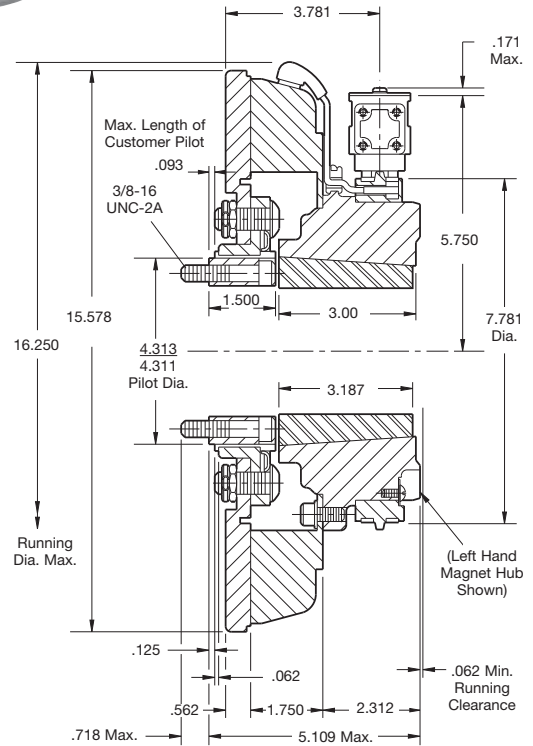

Shaft Size	.937 – 3.000
Static Torque	700 lb.ft.
Maximum Speed	2,000 rpm
Standard Voltage	D.C. 6, 24, 90

All dimensions are nominal unless otherwise noted.

Information on inertia and weights begins on page 239. Coil data is on pages 250 and 251.

Customer Shall Maintain:

1. Splined hub pilot diameter to be concentric with splined armature center of rotation within .010 T.I.R.



Drawing I-25629

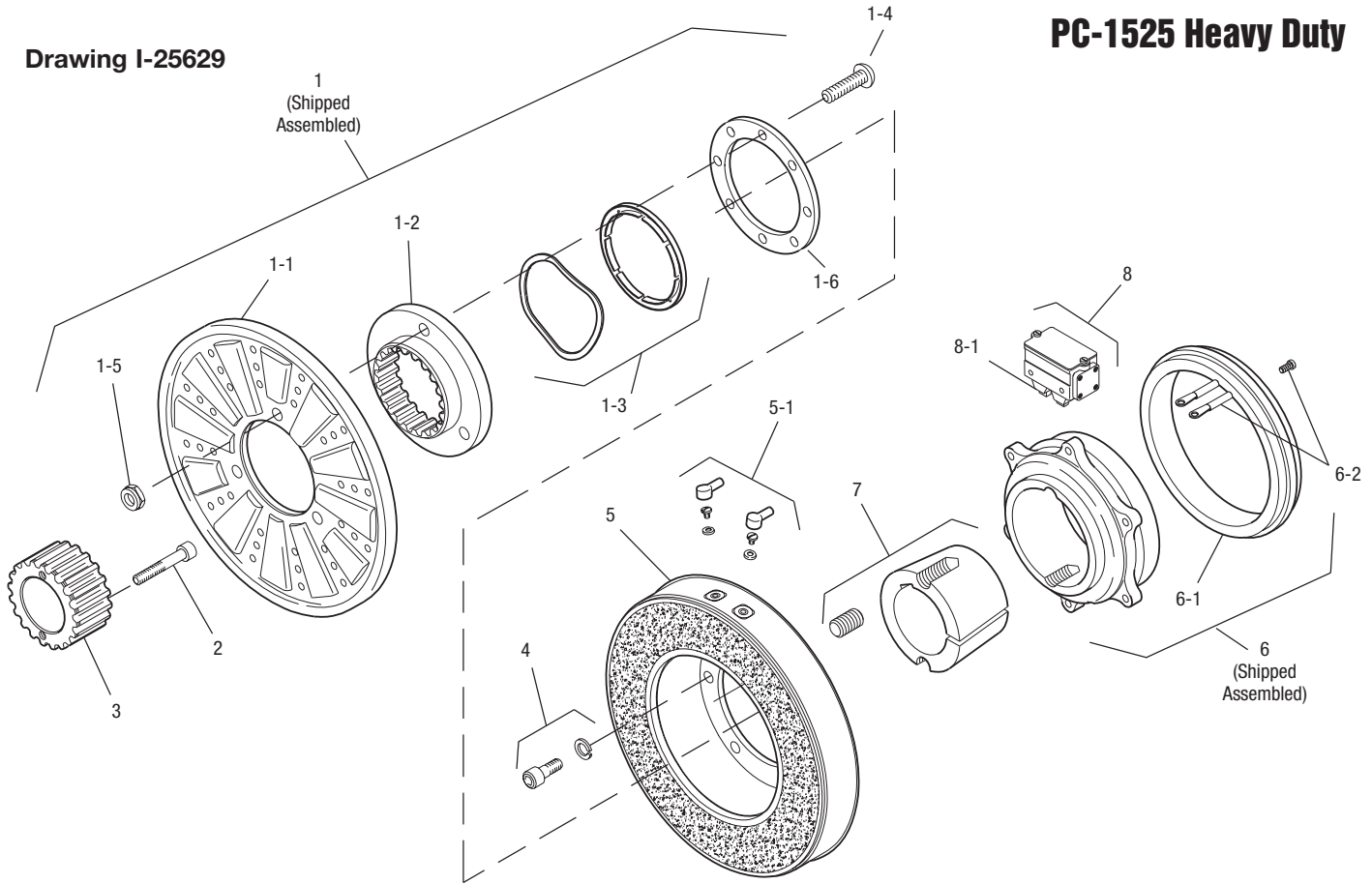

Item	Description	Part Number	Qty.
1	Armature & Splined Adapter Assembly	5324-111-001	1
1-1	Armature	5324-111-034	1
1-2	Splined Armature Adapter	104-0011	1
1-3	Autogap Accessory	5323-101-002	1
	Autogap Spring	808-0044	1
	Retainer Ring	748-0370	1
1-4	Button Head Screw	797-0272	8
1-5	Locknut	661-0004	8
1-6	Retainer Plate	686-0003	1
2	Mounting Accessory	5202-101-001	3
3	Splined Hub	540-0148	1
4	Mounting Accessory	5321-101-001	2
5	Magnet		1
	6 Volt	5304-631-009	
	24 Volt	5304-631-011	
	90 Volt	5304-631-010	
	†90 Volt LK Facing	5304-631-002	
5-1	Terminal Accessory	5311-101-001	1
6	Magnet Hub Assembly		1
	Right Hand	5304-541-002	
	Left Hand (shown)	5304-541-001	

Item	Description	Part Number	Qty.
6-1	Collector Ring	5301-749-001	1
6-2	Collector Ring Accessory	5304-101-004	1
7	Bushing, Taperlock*	180-0262 to 180-0295	1
8	Brushholder	5300-178-001	1
8-1	Brush	176-0001	4

How to Order:

1. Specify Voltage for Item 5.
2. Specify Bore Size for Item 7.
3. Specify left hand or right hand hub for Item 6.
4. See Controls Section.

Example:

PC-1525 Clutch per I-25629 - 90 Volt, L.H. hub, 1" Bore

These units meet the standards of UL508 and are listed under guide card #NMTR2, file #59164.

These units are CSA certified under file #LR11543.

*See page 252 for specific part numbers.

Refer to Service Manual P-0206-WE

†Optional LK facing available. For more information, see page 232.