

PCC Series Clutch Coupling

PCC-500 Normal Duty

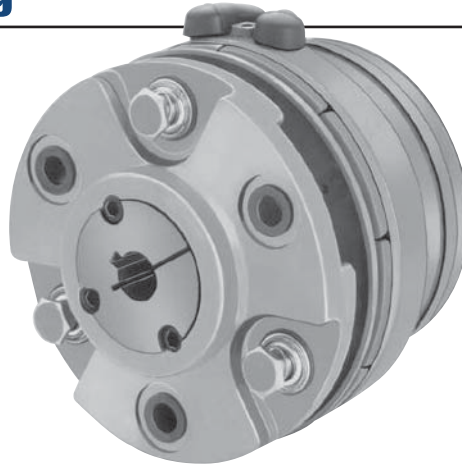

See page 252 for details on Bushings.

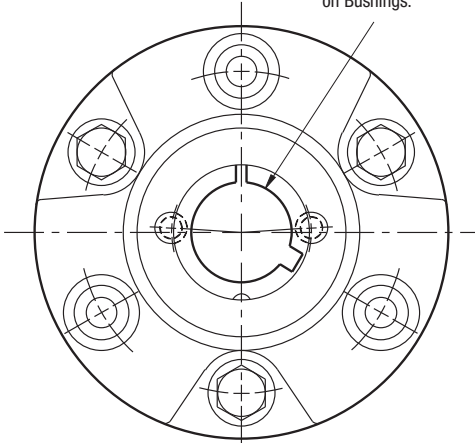

HUB VIEW

1/2-14 NPSM Am. std. straight pipe tap.

See page 252 for details on Bushings.

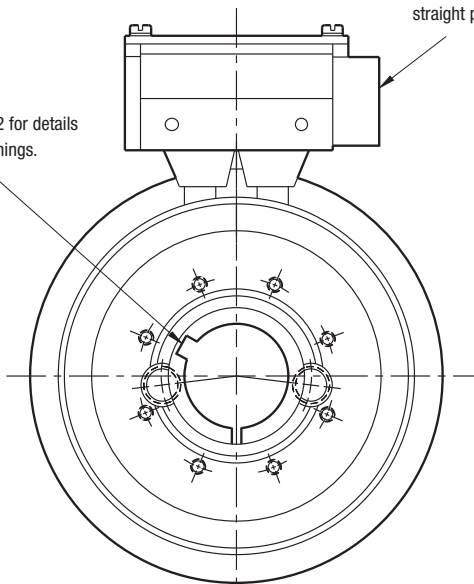

COLLECTOR RING VIEW

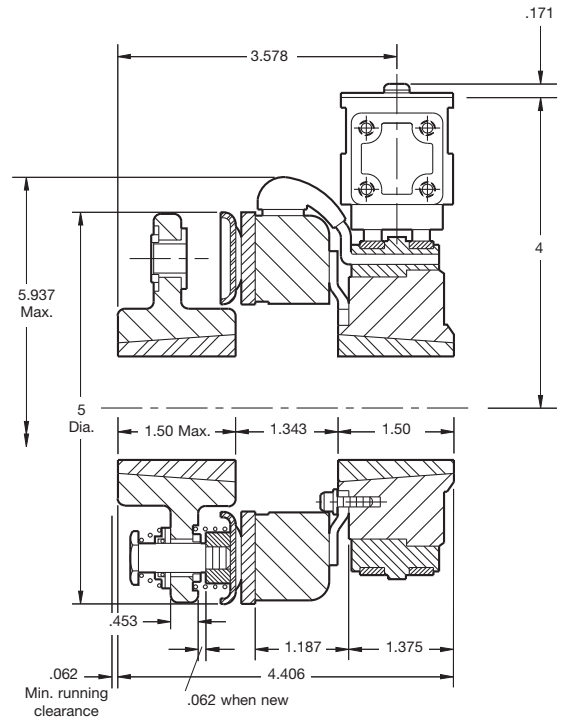

Armature Shaft	.500 – 1.250
Magnet Shaft	.500 – 1.250
Static Torque	40 lb.ft.
Maximum Speed	5,400 rpm
Standard Voltage	D.C. 6, 24, 90

All dimensions are nominal unless otherwise noted.

Information on inertia and weights begins on page 239. Coil data is on pages 250 and 251.

Customer Shall Maintain:

1. Armature mounting shaft concentric with magnet mounting shaft within .006 T.I.R.



PCC Series Clutch Coupling

PCC-500 Normal Duty

Drawing I-25542

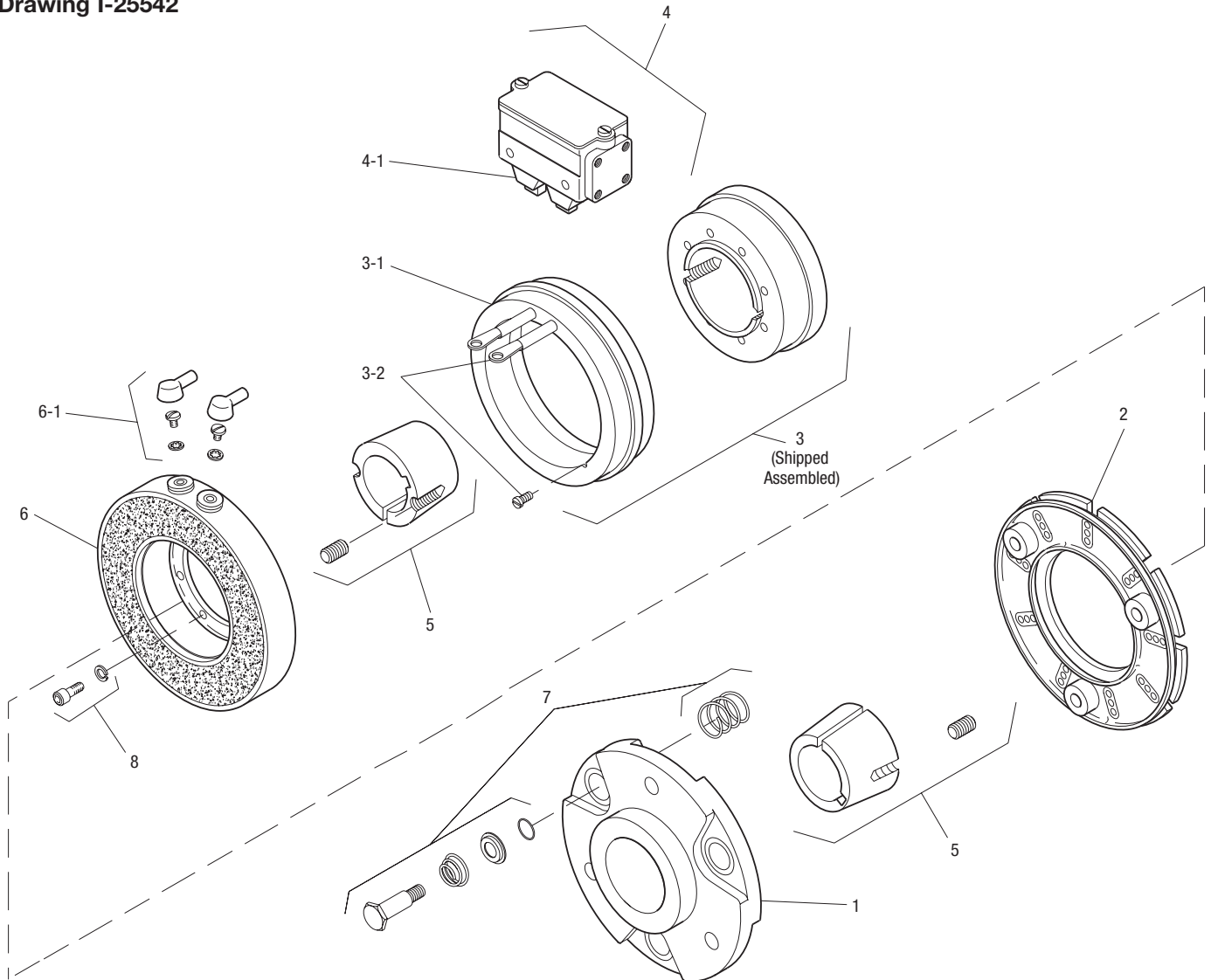

Item	Description	Part Number	Qty.
1	Armature Hub	5300-541-004	1
2	Armature	5300-111-002	1
3	Magnet Hub	5300-541-001	1
3-1	Collector Ring	5300-749-001	1
3-2	Collector Ring Mounting Accessory	5300-101-002	1
4	Brushholder	5300-178-001	1
4-1	Brush	176-0001	4
5	Bushing*		2
	1/2" to 1-1/4" Bore	180-0116 to 180-0128	
6	Magnet		
	6 Volt	5300-631-002	
	24 Volt	5300-631-003	
	90 Volt	5300-631-005	
6-1	Terminal Accessory	5311-101-001	1
7	Autogap Accessory	5200-101-009	3

Item	Description	Part Number	Qty.
8	Mounting Accessory	5102-101-001	2

How to Order:

1. Specify Bore Size for Item 5 (two shafts).
2. Specify Voltage for Item 7.
3. See Controls Section.

Example:

PCC-500 Clutch Coupling per I-25542 - 90 Volt, 3/4" Bore

These units meet standards set forth in UL508 and are listed under guide card #NMTR2, file #59164.

These units are CSA certified under file #LR11543

*See page 252 for specific part numbers.

Refer to Service Manual P-0203-WE

PCC Series Clutch Coupling

PCC-500 Heavy Duty



For Bore & Keyway sizes see chart below.

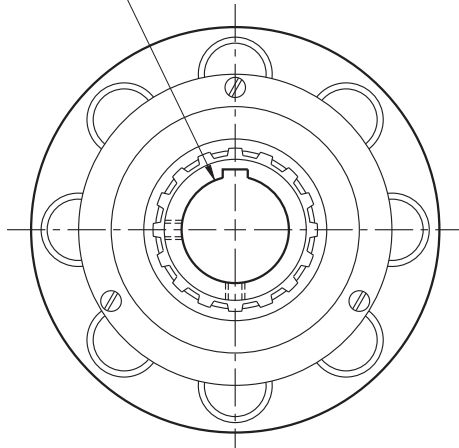

ARMATURE VIEW

See page 252 for details on Bushings.

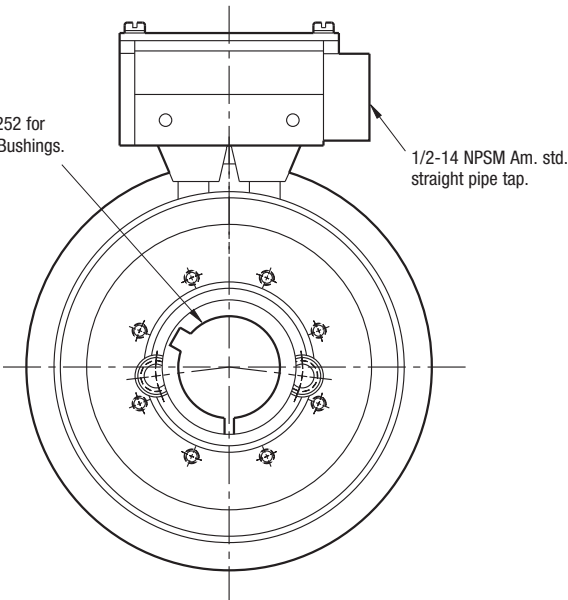

COLLECTOR RING VIEW

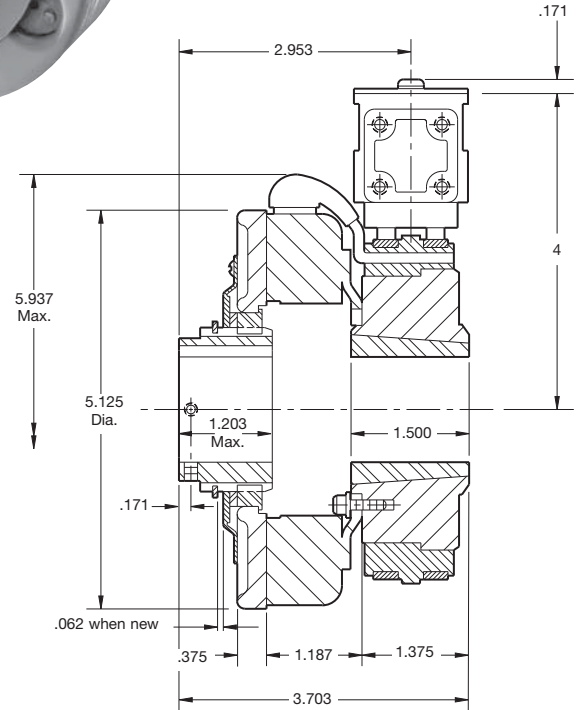

Bore & Keyway Dimensions

Armature Bore Dia.	Keyway
.751/.750 .876/.875	.187 x .093
.9385/.9375 1.001/1.000 1.126/1.125 1.251/1.250	.250 x .125
Armature Shaft	.750 – 1.250
Magnet Shaft	.500 – 1.250
Static Torque	40 lb.ft.
Maximum Speed	5,400 rpm
Standard Voltage	D.C. 6, 24, 90

Customer Shall Maintain:

1. Armature mounting shaft concentric with magnet mounting shaft within .006 T.I.R.

All dimensions are nominal unless otherwise noted.

Information on inertia and weights begins on page 239. Coil data is on pages 250 and 251.



PCC Series Clutch Coupling

PCC-500 Heavy Duty

Drawing I-25543

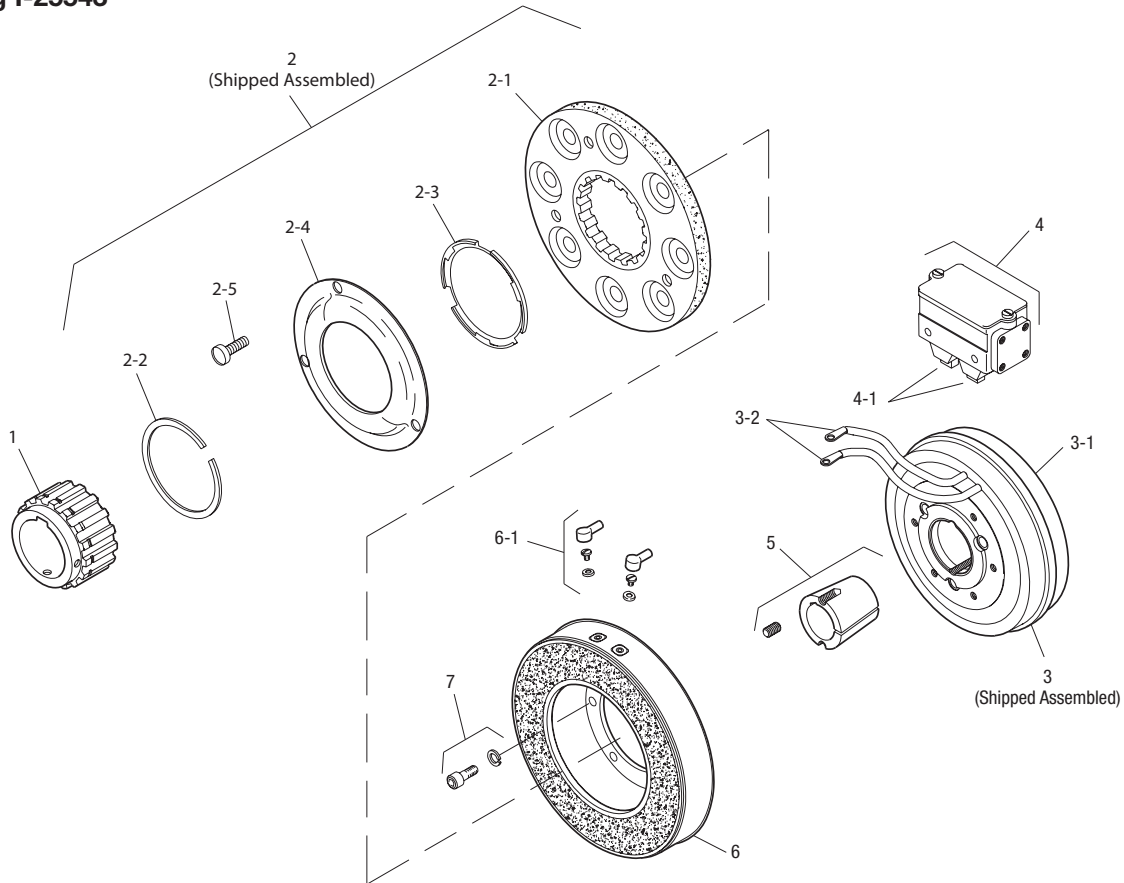

Item	Description	Part Number	Qty.
1	Armature Hub		1
	3/4" Bore	5200-541-002	
	7/8" Bore	5200-541-003	
	15/16" Bore	5200-541-004	
	1" Bore	5200-541-005	
	1-1/8" Bore	5200-541-006	
	1-1/4" Bore	5200-541-007	
2	Armature Assembly	5230-111-002	1
2-1	Armature	5230-111-001	1
2-2	Retainer Ring	748-0355	1
2-3	Autogap Spring	808-0412	1
2-4	Retainer Plate	748-0364	1
2-5	Screw	797-0028	3
3	Magnet Hub	5300-541-001	1
3-1	Collector Ring	5300-749-001	1
3-2	Collector Ring Mounting Acc.	5300-101-002	1
4	Brushholder	5300-178-001	1
4-1	Brush	176-0001	4
5	Bushing*		2
	1/2" to 1-1/4" Bore	180-0116 to 180-0128	

Item	Description	Part Number	Qty.
6	Magnet		1
	6 Volt	5300-631-002	
	24 Volt	5300-631-003	
	90 Volt	5300-631-005	
6-1	Terminal Accessory	5311-101-001	1
7	Mounting Accessory	5102-101-001	2

How to Order:

1. Specify Bore Size for Item 1 and Item 5.
2. Specify Voltage for Item 6.
3. See Controls Section.

Example:

PCC-500 Clutch Coupling per I-25543 - 90 Volt, 3/4" Armature Hub Bore, 1" Bushing Bore

These units meet standards set forth in UL508 and are listed under guide card #NMTR2, file #59164.

These units are CSA certified under file #LR11543.

*See page 252 for specific part numbers.

Refer to Service Manual P-0203-WE

PCC Series Clutch Coupling

PCC-825

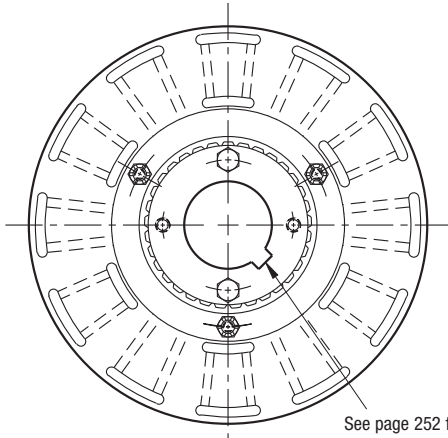

ARMATURE VIEW

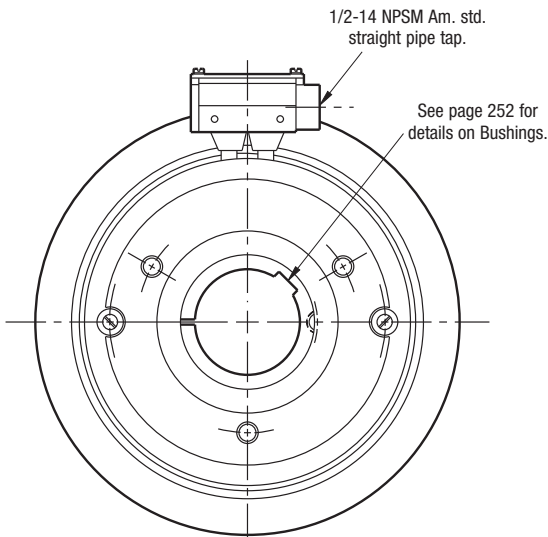

COLLECTOR RING VIEW

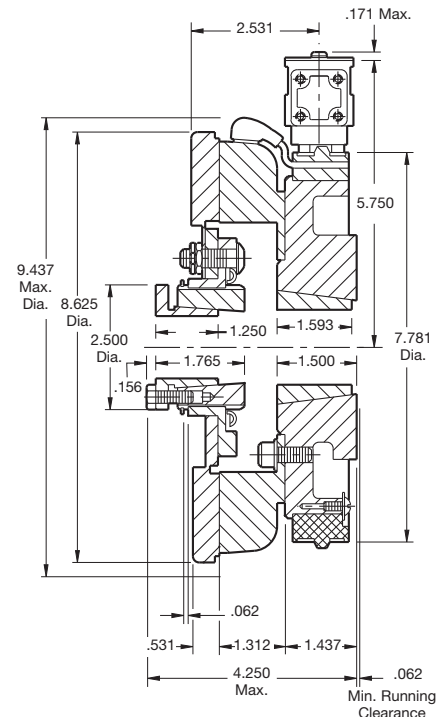

Armature Shaft	.500 – 1.500
Magnet Shaft	.500 – 1.625
Static Torque	125 lb.ft.
Maximum Speed	4,000 rpm
Standard Voltage	D.C. 6, 24, 90

Customer Shall Maintain:

1. Armature mounting shaft concentric with magnet mounting shaft within .006 T.I.R.
2. Angular alignment of shafts within 1/2 degree.

All dimensions are nominal unless otherwise noted.

Information on inertia and weights begins on page 239. Coil data is on pages 250 and 251.



PCC Series Clutch Coupling

PCC-825

Drawing I-25565

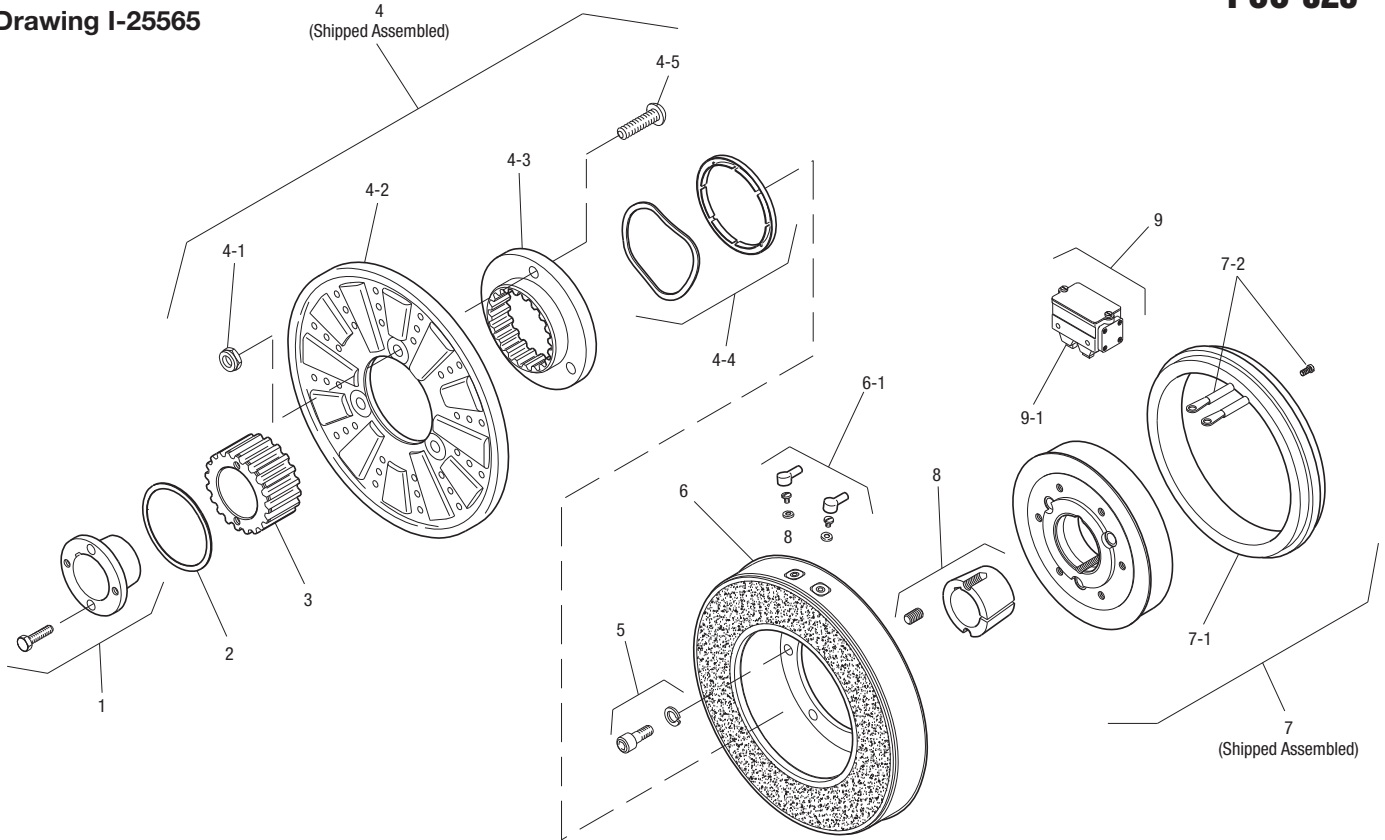

Item	Description	Part Number	Qty.
1	Bushing*		1
	1/2" to 1-1/2" Bore	180-0002 to 180-0018	
2	Retainer Ring	748-0006	1
3	Splined Hub	540-0057	1
4	Armature & Splined Adapter	5321-111-001	1
4-1	Locknut	661-0004	3
4-2	Armature	5321-111-022	1
4-3	Splined Adapter	104-0008	1
4-4	Autogap Accessory	5321-101-006	1
4-5	Screw	797-0272	3
5	Mounting Accessory	5321-101-001	1
6	Magnet		1
	6 Volt	5301-631-002	
	24 Volt	5301-631-004	
	90 Volt	5301-631-005	
	†90 Volt Optional LK Facing	5301-631-011	
6-1	Terminal Accessory	5311-101-001	1
7	Magnet Hub		1
	Left Hand (shown)	5301-541-001	
	Right Hand	5301-541-002	
7-1	Collector Ring	5301-749-001	1
7-2	Collector Ring Accessory	5301-101-002	1
8	Bushing*		1
	1/2" to 1-5/8" Bore	180-0131 to 180-0149	

Item	Description	Part Number	Qty.
9	Brushholder	5300-178-001	1
9-1	Brush	176-0001	4

How to Order:

1. Specify Bore Size for Item 1.
2. Specify Voltage for Item 6.
3. Specify left hand or right hand hub for Item 7. (Bushing enters from magnet side for L.H. hub and from hub side for R.H.)
4. Specify Bore Size for Item 8.
5. See Controls Section.

Example:

PCC-825 Clutch Coupling per I-25565 - 90 Volt, L.H. hub, 1" Bore (Item 1), 1-1/2" Bore (Item 8)

These units meet the standards of UL508 and are listed under guide card #NMTR2, file #59164.

These units are CSA certified under file #LR11543

*See page 252 for specific part numbers.

Refer to Service Manual P-0206-WE

†Optional LK facing available. For more information, see page 232.

PCC Series Clutch Coupling

PCC-1000

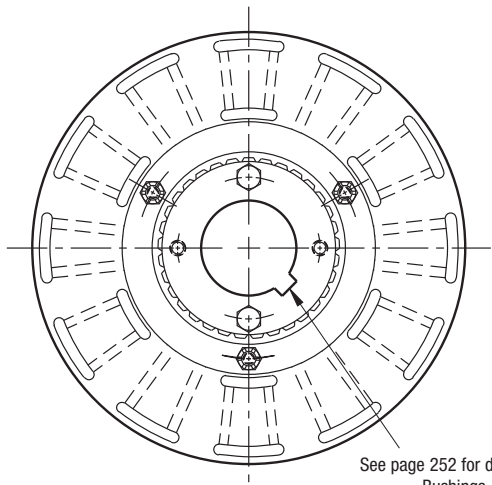

ARMATURE VIEW

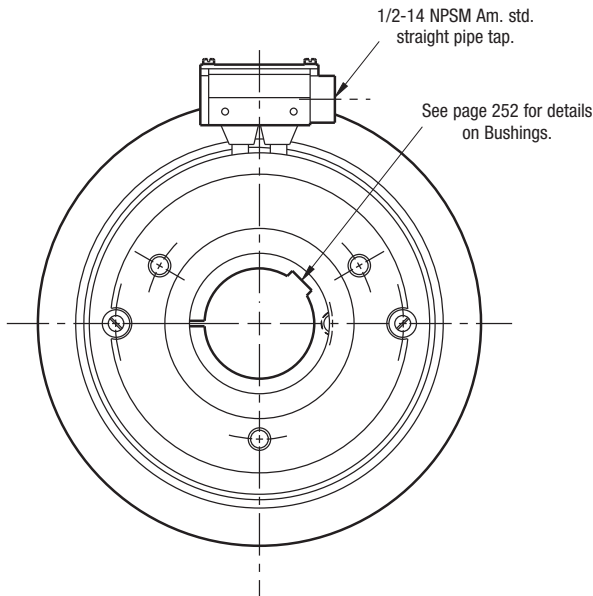

COLLECTOR RING VIEW

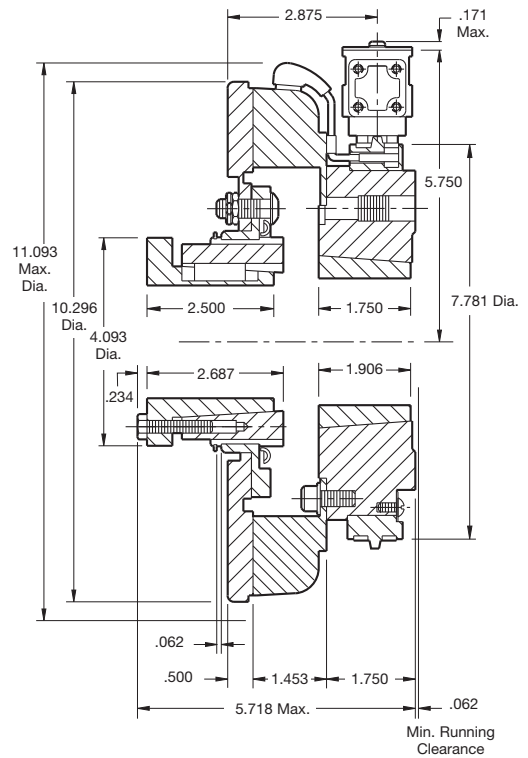

Armature Shaft	.750 – 2.687
Magnet Shaft	.500 – 2.500
Static Torque	240 lb.ft.
Maximum Speed	3,600 rpm
Standard Voltage	D.C. 6, 24, 90

Customer Shall Maintain:

1. Armature mounting shaft concentric with magnet mounting shaft within .006 T.I.R.
2. Angular alignment of shafts within 1/2 degree.

All dimensions are nominal unless otherwise noted.

Information on inertia and weights begins on page 239. Coil data is on pages 250 and 251.



PCC Series Clutch Coupling

PCC-1000

Drawing I-25585

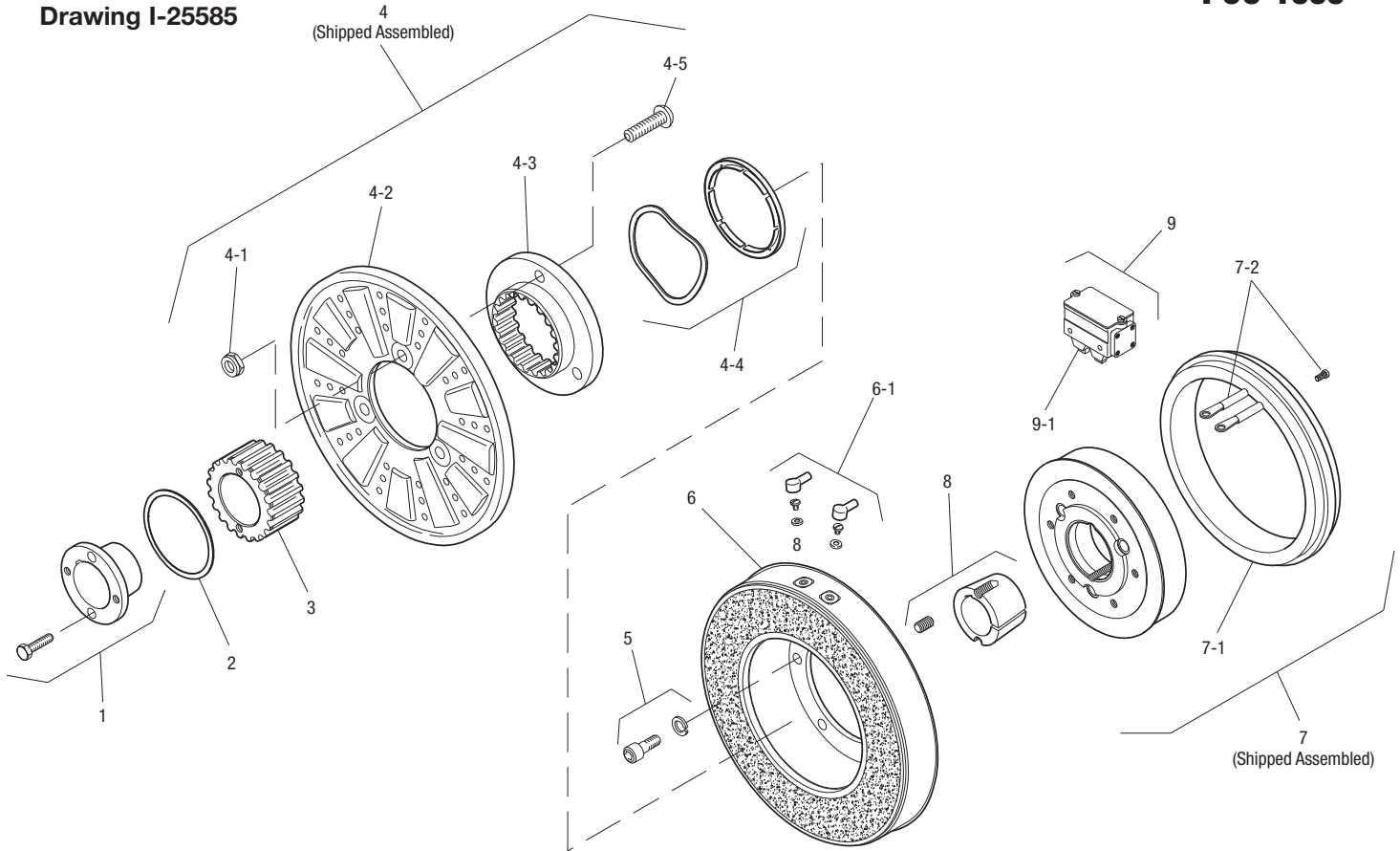

Item	Description	Part Number	Qty.
1	Bushing*		1
	3/4" to 2-11/16" Bore	180-0026 to 180-0057	
2	Retainer Ring	748-0007	1
3	Splined Hub	540-0062	1
4	Armature & Splined Adapter	5322-111-002	1
4-1	Locknut	661-0004	3
4-2	Armature	5322-111-036	1
4-3	Splined Adapter	104-0009	1
4-4	Autogap Accessory	5322-101-004	1
4-5	Screw	797-0272	3
5	Mounting Accessory	5321-101-001	1
6	Magnet		1
	6 Volt	5302-631-003	
	24 Volt	5302-631-014	
	90 Volt	5302-631-005	
	†90 Volt Optional LK Facing	5302-631-001	
6-1	Terminal Accessory	5311-101-001	1
7	Magnet Hub		1
	Left Hand (shown)	5302-541-001	
	Right Hand	5302-541-002	
7-1	Collector Ring	5301-749-001	1
7-2	Collector Ring Accessory	5302-101-002	1

Item	Description	Part Number	Qty.
8	Bushing*		1
	1/2" to 2-1/2" Bore	180-0185 to 180-0217	
9	Brushholder	5300-178-001	1
9-1	Brush	176-0001	4

How to Order:

1. Specify Bore Size for Item 1.
2. Specify Voltage for Item 6.
3. Specify left hand or right hand hub for Item 7. (Bushing enters from magnet side for L.H. hub and from hub side for R.H.)
4. Specify Bore Size for Item 8.
5. See Controls Section.

Example:

PCC-1000 Clutch Coupling per I-25585 - 90 Volt, L.H. hub, 1-1/2" Bore (Item 1), 2" Bore (Item 8)

These units meet the standards of UL508 and are listed under guide card #NMTR2, file #59164.

These units are CSA certified under file #LR11543

*See page 252 for specific part numbers.

Refer to Service Manual P-0206-WE

†Optional LK facing available. For more information, see page 232.

PCC Series Clutch Coupling

PCC-1225

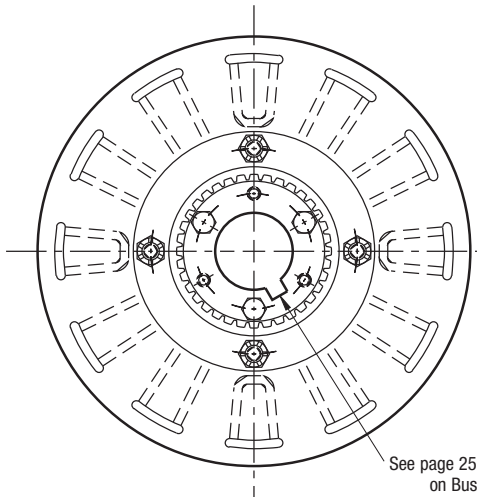

ARMATURE VIEW

See page 252 for details on Bushings.

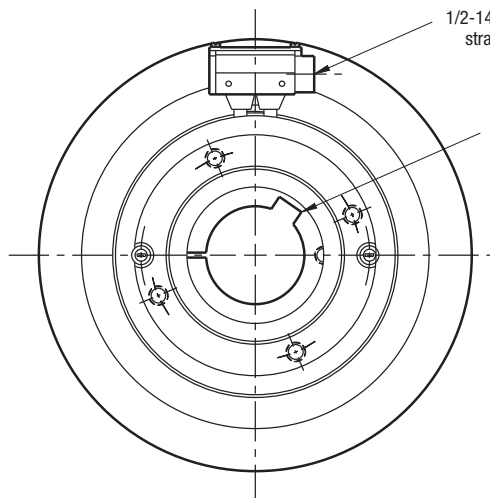

**PCC-1225
COLLECTOR RING VIEW**

1/2-14 NPSM Am. std. straight pipe tap.

See page 252 for details on Bushings.

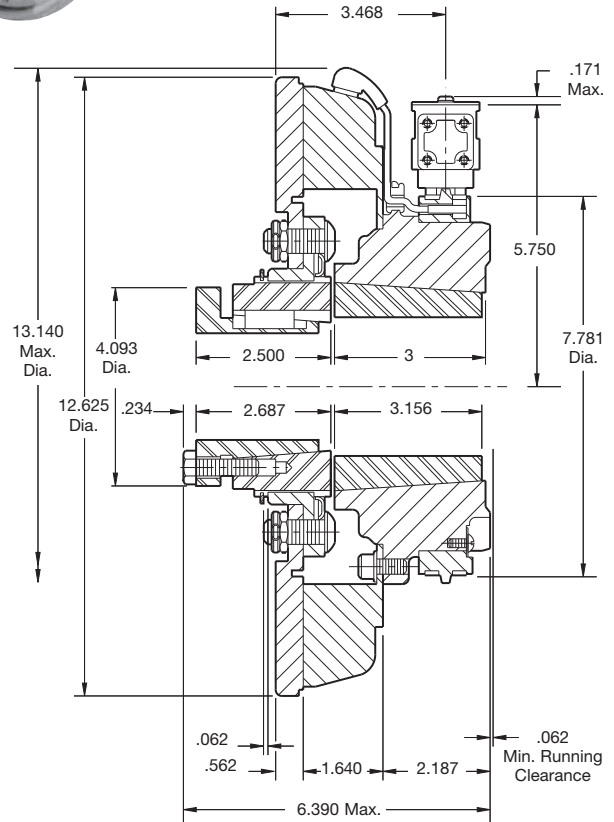

Armature Shaft	.750 – 2.687
Magnet Shaft	.937 – 3.00
Static Torque	465 lb.ft.
Maximum Speed	3,000 rpm
Standard Voltage	D.C. 6, 24, 90

Customer Shall Maintain:

1. Armature mounting shaft concentric with magnet mounting shaft within .006 T.I.R.
2. Angular alignment of shafts within 1/2 degree.

All dimensions are nominal unless otherwise noted.

Information on inertia and weights begins on page 239. Coil data is on pages 250 and 251.



PCC Series Clutch Coupling

PCC-1225

Drawing I-25605

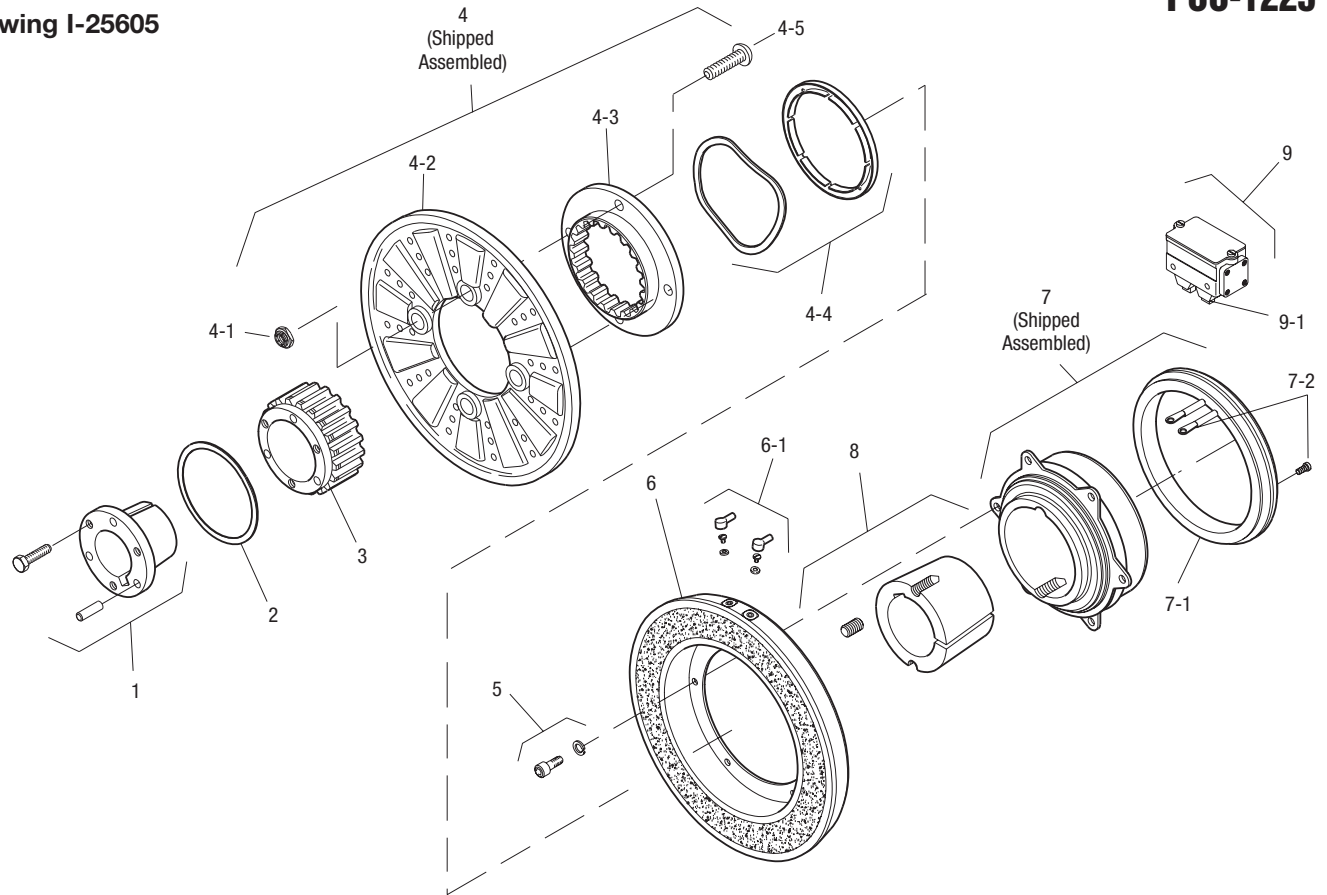

Item	Description	Part Number	Qty.
1	Bushing*		1
	3/4" to 2-11/16" Bore	180-0026 to 180-0057	
2	Retainer Ring	748-0005	1
3	Splined Hub	540-0064	1
4	Armature & Splined Adapter	5323-111-001	1
4-1	Locknut	661-0005	4
4-2	Armature	5323-111-034	1
4-3	Splined Adapter	104-0010	1
4-4	Autogap Accessory	5323-101-002	1
4-5	Screw	797-0281	4
5	Mounting Accessory	5321-101-001	1
6	Magnet		1
	6 Volt	5303-631-005	
	24 Volt	5303-631-007	
	90 Volt	5303-631-008	
	†90 Volt Optional LK Facing	5303-631-001	
6-1	Terminal Accessory	5311-101-001	1
7	Magnet Hub		1
	Left Hand (shown)	5303-541-001	
	Right Hand	5303-541-002	
7-1	Collector Ring	5301-749-001	1
7-2	Collector Ring Accessory	5303-101-004	1

Item	Description	Part Number	Qty.
8	Bushing*		1
	15/16" to 3" Bore	180-0262 to 180-0295	
9	Brushholder	5300-178-001	1
9-1	Brush	176-0001	4

How to Order:

1. Specify Bore Size for Item 1.
2. Specify Voltage for Item 6.
3. Specify left hand or right hand hub for Item 7. (Bushing enters from magnet side for L.H. hub and from hub side for R.H.)
4. Specify Bore Size for Item 8.
5. See Controls Section.

Example:

PCC-1225 Clutch Coupling per I-25605 - 90 Volt, L.H. hub, 1-1/2" Bore (Item 1), 2" Bore (Item 8)

These units meet the standards of UL508 and are listed under guide card #NMTR2, file #59164.

These units are CSA certified under file #LR11543.

*See page 252 for specific part numbers.

Refer to Service Manual P-0206-WE

†Optional LK facing available. For more information, see page 232.

PCC Series Clutch Coupling

PCC-1525

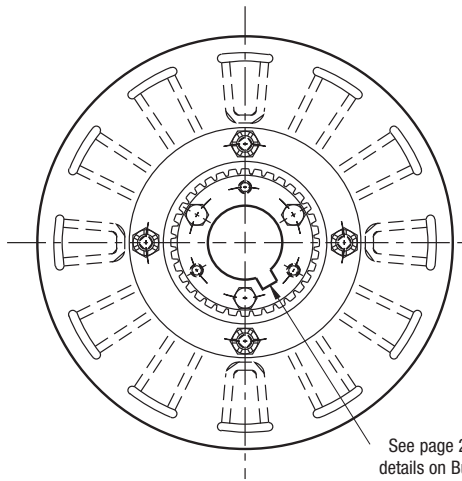

ARMATURE VIEW

See page 252 for details on Bushings.

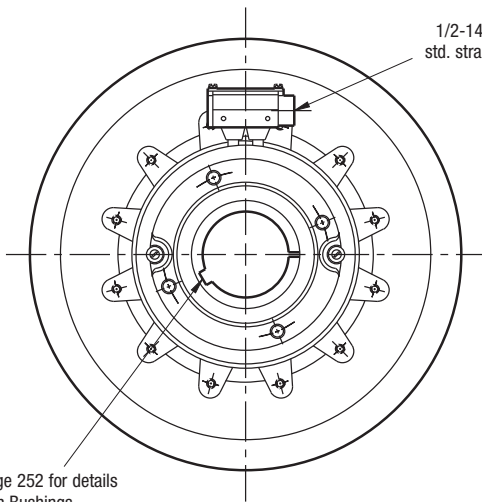

**PCC-1525
COLLECTOR RING VIEW**

1/2-14 NPSM Am. std. straight pipe tap.

See page 252 for details on Bushings.

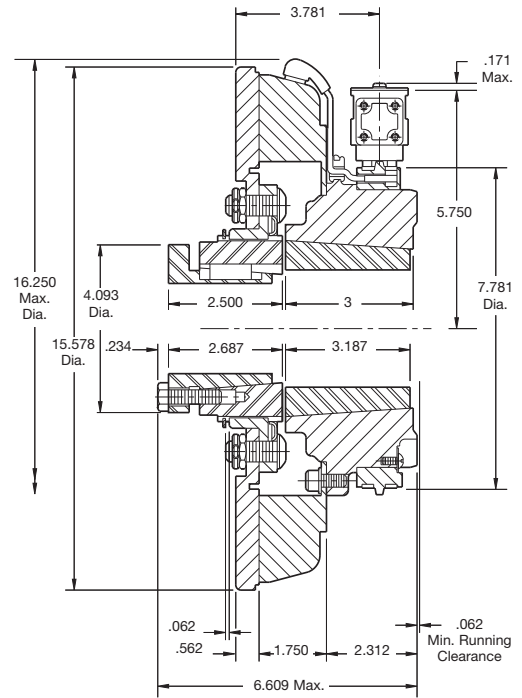

Armature Shaft	.750 – 2.687
Magnet Shaft	.937 – 3.00
Static Torque	700 lb.ft.
Maximum Speed	2,000 rpm
Standard Voltage	D.C. 6, 24, 90

Customer Shall Maintain:

1. Armature mounting shaft concentric with magnet mounting shaft within .006 T.I.R.
2. Angular alignment of shafts within 1/2 degree.

All dimensions are nominal unless otherwise noted.

Information on inertia and weights begins on page 239. Coil data is on pages 250 and 251.



PCC Series Clutch Coupling

PCC-1525

Drawing I-25632

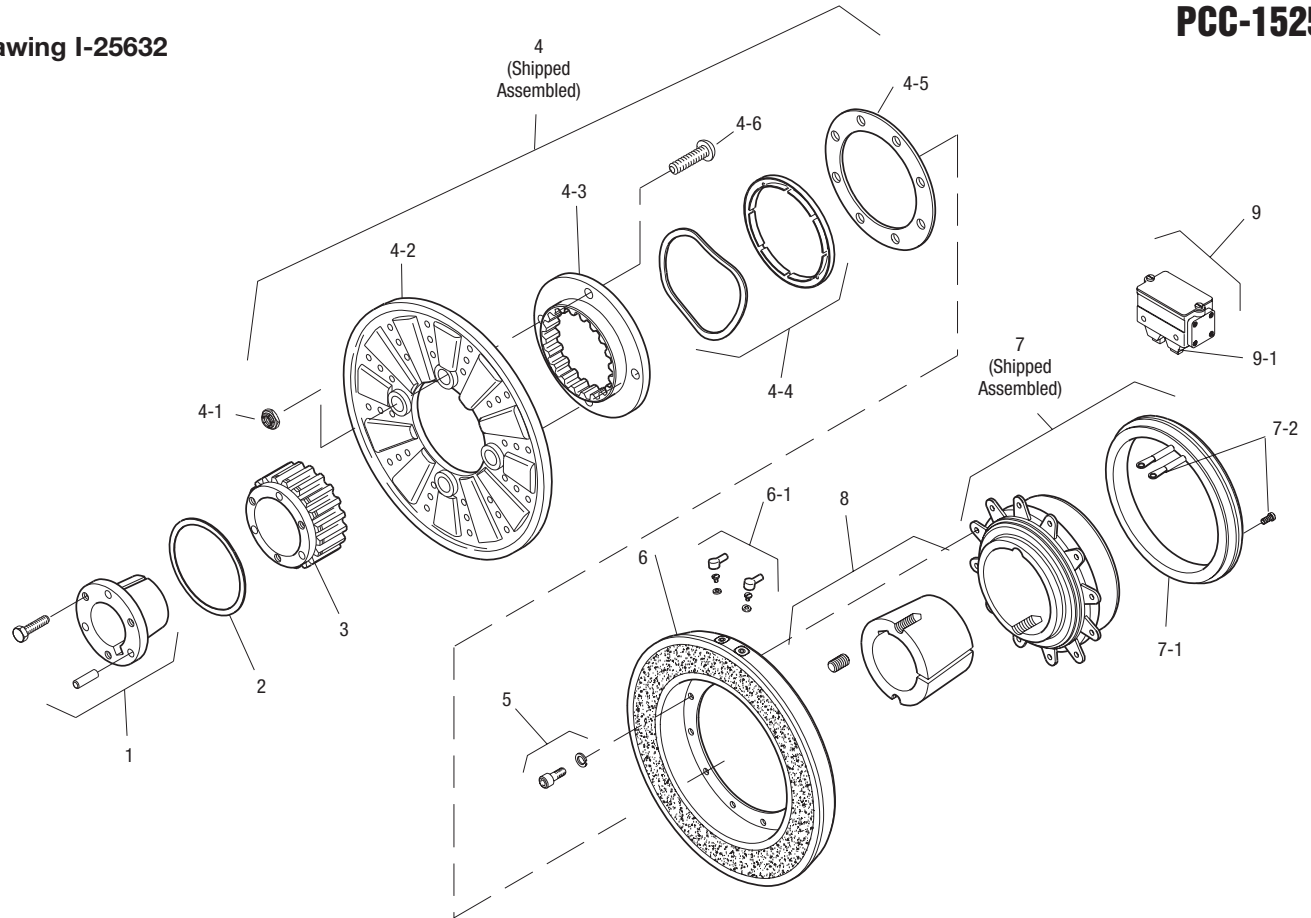

Item	Description	Part Number	Qty.
1	Bushing*		1
	3/4" to 2-11/16" Bore	180-0026 to 180-0057	
2	Retainer Ring	748-0005	1
3	Splined Hub	540-0064	1
4	Armature & Splined Adapter	5324-111-001	1
4-1	Locknut	661-0004	8
4-2	Armature	5324-111-034	1
4-3	Splined Adapter	104-0011	1
4-4	Autogap Accessory	5323-101-002	1
4-5	Retainer Plate	686-0003	1
4-6	Screw	797-0272	8
5	Mounting Accessory	5321-101-001	2
6	Magnet		1
	6 Volt	5304-631-009	
	24 Volt	5304-631-011	
	90 Volt	5304-631-010	
	†90 Volt Optional LK Facing	5304-631-002	
6-1	Terminal Accessory	5311-101-001	1
7	Magnet Hub		1
	Left Hand (shown)	5304-541-001	
	Right Hand	5304-541-002	
7-1	Collector Ring	5301-749-001	1
7-2	Collector Ring Accessory	5304-101-004	1

Item	Description	Part Number	Qty.
8	Bushing*		1
	15/16" to 3" Bore	180-0262 to 180-0295	
9	Brushholder	5300-178-001	1
9-1	Brush	176-0001	4

How to Order:

1. Specify Bore Size for Item 1.
2. Specify Voltage for Item 6.
3. Specify left hand or right hand hub for Item 7. (Bushing enters from magnet side for L.H. hub and from hub side for R.H.)
4. Specify Bore Size for Item 8.
5. See Controls Section.

Example:

PCC-1525 Clutch Coupling per I-25632 - 90 Volt, L.H. hub, 1-1/2" Bore (Item 1), 2" Bore (Item 8)

These units meet the standards of UL508 and are listed under guide card #NMTR2, file #59164.

These units are CSA certified under file #LR11543.

*See page 252 for specific part numbers.

Refer to Service Manual P-0206-WE

†Optional LK facing available. For more information, see page 232.