

TL17

series

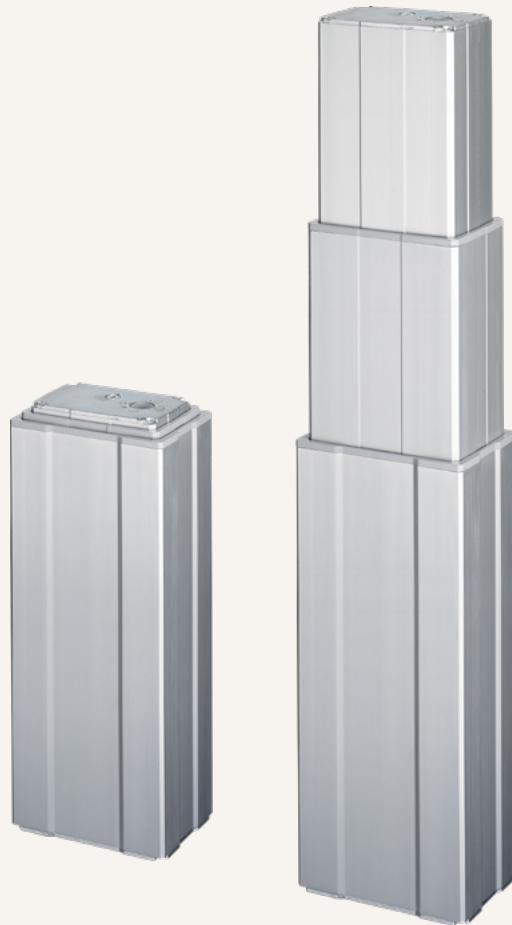

Product Segments

- **Care Motion**
- **Comfort Motion**
- **Ergo Motion**
- **Industrial Motion**

TiMOTION's TL17 series electric lifting columns are designed for any height adjustable workstation applications, such as the medical bed for healthcare industry. Constructed with an extruded aluminum rectangular appearance, our TL17 lift column provides a high degree of stability. This column makes engineering and design processes easier and the system safer by replacing older style lifting mechanisms that have many moving parts and pinch points. The 3 stage, telescopic design provides a greatly reduced retracted height and an increased stroke length.

General Features

Max. load	2,000N (push)
Max. dynamic bending moment	250Nm
Max. static bending moment	500Nm
Max. speed at max. load	11.5mm/s
Max. speed at no load	41mm/s
Retracted length	≥ Stroke / 2+150mm
IP rating	IPX6
Dimension of outer tube	3-stage, 169.4*121.4mm rectangular
Stroke	250~1200mm
Certificate	IEC60601-1, ES60601-1, IEC60601-1-2
Options	Hall sensor(s)
Color	Silver, black
Operational temperature range	+5°C~+45°C

Drawing

Standard Dimensions
(mm)

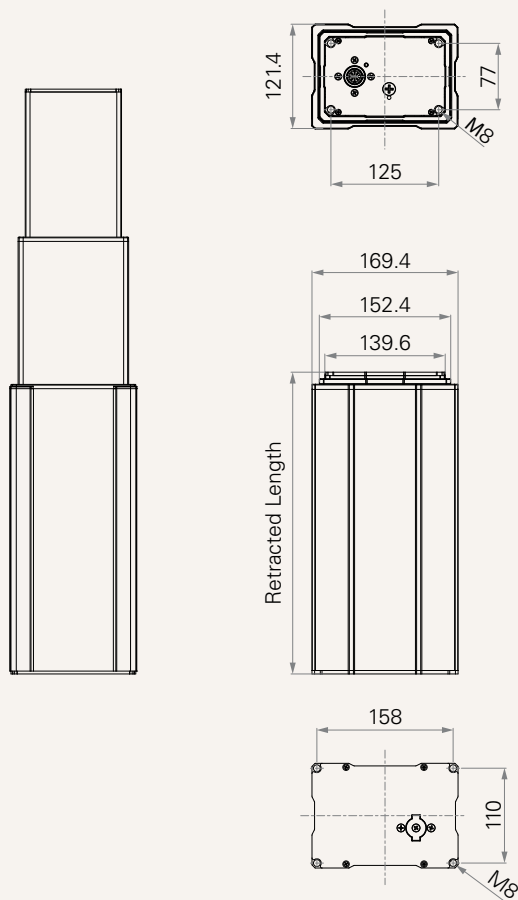

Load and Speed

CODE	Load (N)	Self Locking Force (N)	Typical Current (A)		Typical Speed (mm/s)	
	Push		No Load 32V DC	With Load 24V DC	No Load 32V DC	With Load 24V DC
Motor Speed (2800RPM)						
B	2000	2000	2.5	4.0	22.0	11.5
C	1000	1000	2.5	4.3	41.0	22.0
D	1500	1500	2.5	4.5	34.5	16.0

Note

- 1 Please refer to the approved drawing for the final authentic value.
- 2 The current & speed in table are tested with 24V DC motor. With a 12V DC motor, the current is approximately twice the current measured in 24V DC; speed will be similar for both voltages.
- 3 This self-locking force level is reached only when a short circuit is applied on the terminals of the motor. All the TiMOTION control boxes have this feature built-in.
- 4 Bending moment Y direction = $X \cdot 0.8$
- 5 Static bending moment = dynamic * 2

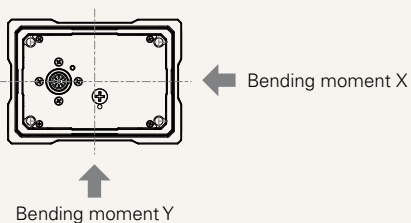

Dynamic bending moment (Nm) - X direction	
Retracted length (mm)	$(S/2) + 150$
Stroke (mm)	250-1200 250

Performance Data (24V DC Motor)

Motor Speed (2800RPM)

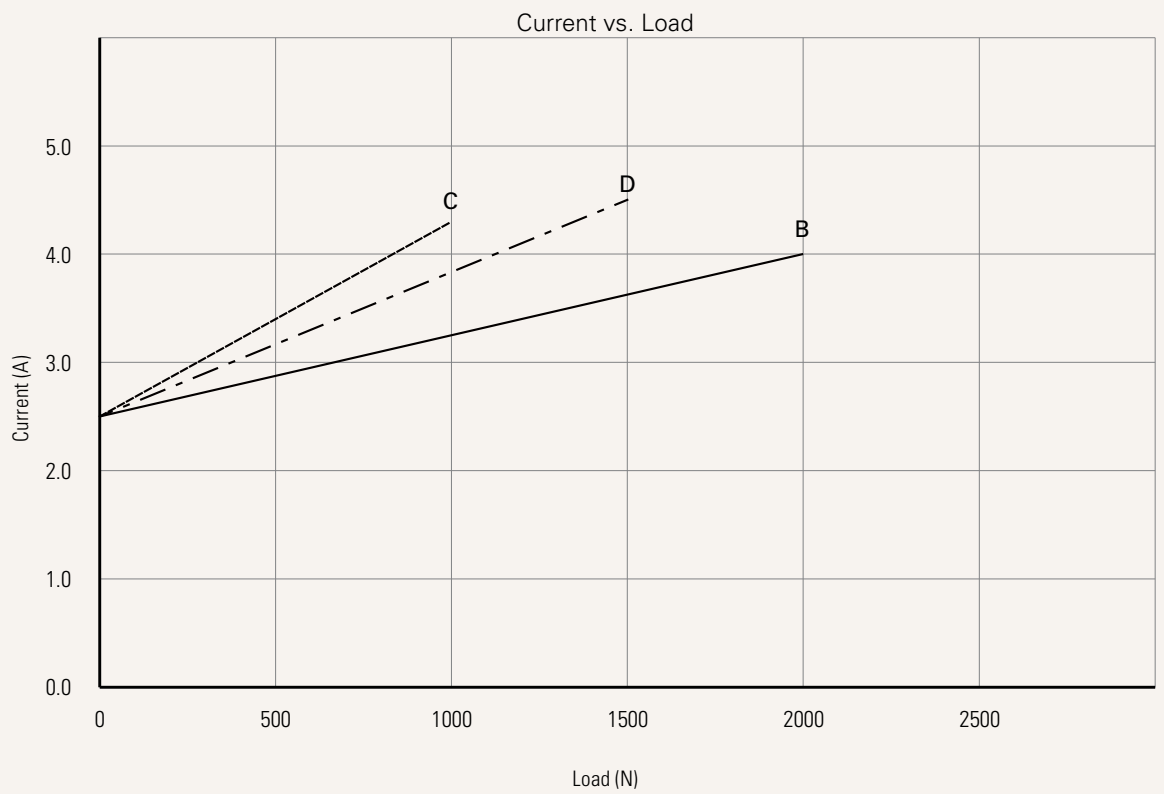
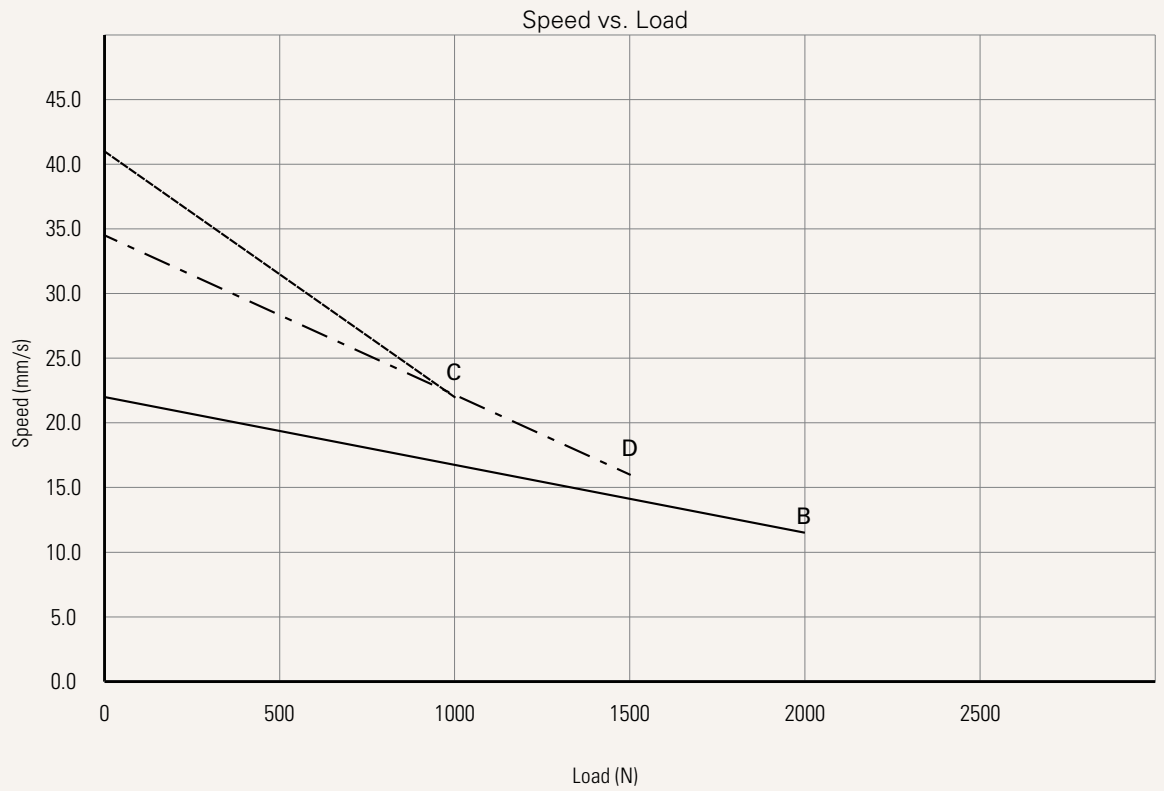

TL17 Ordering Key - Front End Socket

TL17

Version: 20190419-J

Voltage	1 = 12V DC	5 = 24V DC, PTC
Load and Speed	See page 2	
Stroke (mm)	250-1200	
Retracted Length (mm)	Minimum retract length needs to $\geq (\text{stroke} / 2) + 150$	
Cable Exit See page 8	1 = Top end socket	
Special Functions for Spindle Sub-Assembly	0 = Without (standard)	1 = Safety nut
Functions for Limit Switches See page 8	1 = Two switches at full retracted / extended positions to cut current 3 = Two switches at full retracted / extended positions to send signal	
IP Rating	1 = Without	2 = IPX4 3 = IPX6
Output Signals	0 = Without	2 = Hall sensor*2
Connector See page 8	1 = DIN 6P, socket	
Cable Length (mm)	0 = Without (the corresponding extension cable TEC needs to be ordered separately)	
Color	1 = Black	2 = Matte silver
Tubes Direction See page 9	0 = Thinner on top	1 = Wider on top
Grounding Function	0 = Without	1 = With

Note

1 TL17 is designed especially for push applications, not suitable for pull applications.

TL17 Ordering Key - Side Cable

TL17

Version: 20190419-J

Voltage	1 = 12V DC	5 = 24V DC, PTC		
Load and Speed	See page 2			
Stroke (mm)	250-1200			
Retracted Length (mm)	See page 7			
Cable Exit	2 = Bottom side cable	3 = Top side cable		
	See page 8			
Special Functions for Spindle Sub-Assembly	0 = Without (standard)	1 = Safety nut		
Functions for Limit Switches	1 = Two switches at full retracted / extended positions to cut current			
	3 = Two switches at full retracted / extended positions to send signal			
	See page 8			
IP Rating	1 = Without	2 = IPX4	3 = IPX6	
Output Signals	0 = Without	2 = Hall sensor*2		
Connector	1 = DIN 6P, 90° plug	2 = Tinned leads	E = Molex 8P, plug	F = DIN 6P, 180° plug
	See page 8			
Cable Length (mm)	1 = Straight, 500	3 = Straight, 1000	5 = Straight, 1500	7 = Straight, 2000
	2 = Straight, 750	4 = Straight, 1250	6 = Straight, 1750	
Color	1 = Black (Black cable set)		3 = Matte silver (Black cable set)	
	2 = Matte silver (428C color cable set)			
Tubes Direction	0 = Thinner on top	1 = Wider on top		
	See page 9			
Grounding Function	0 = Without	1 = With		

Note

1 TL17 is designed especially for push applications, not suitable for pull applications.

Voltage	1 = 12V DC	5 = 24V DC, PTC
Load and Speed	See page 2	
Stroke (mm)	250-1200	
Retracted Length (mm)	See page 7	
Cable Exit See page 8	B = Top side - for TH; Bottom side- for TP C = Bottom side - Y cable, for TH + TP D = Top side - for the 2nd column; Bottom side - for TH & TP; direct cut operation with 2 columns E = Top side - for the 2nd column & TH; Bottom side - for TP; direct cut operation with 2 columns	
Special Functions for Spindle Sub-Assembly	0 = Without (standard)	1 = Safety nut
Functions for Limit Switches See page 8	1 = Two switches at full retracted / extended positions to cut current	
IP Rating	1 = Without	2 = IPX4 3 = IPX6
Output Signals	0 = Without	
Connector See page 9	C = Direct cut, water proof, anti-pull	
Cable Length (mm) See page 9	B = Cable exit #B, L2=L3=100 C = Cable exit #C, L1=L2=L3=100 D = Cable exit #D, L2=L3=L4=100 E = Cable exit #E, L2=L3=L4=100	
Color	1 = Black (Black cable set) 2 = Matte silver (428C color cable set)	3 = Matte silver (Black cable set)
Tubes Direction See page 9	0 = Thinner on top	1 = Wider on top
Grounding Function	0 = Without	1 = With

Note

1 TL17 is designed especially for push applications, not suitable for pull applications.

Retracted Length (mm)

1. Retracted length needs to $\geq A+B$

A. Load (N)	2000	1000	1500
	(S/2) + 150		

Note

1 Different retracted length is relative to different bending moment, [See page 2.](#)

B. Cable Exit

CODE	Top End Socket	Bottom Side Cable	Top Side Cable	Direct Cut	
	1	2	3	B, D, E	C
B	-	+20	+15	+35	+20

Functions for Limit Switches

Wire Definitions

CODE	Pin					
	● 1 (Green)	● 2 (Red)	○ 3 (White)	● 4 (Black)	● 5 (Yellow)	● 6 (Blue)
1	extend (VDC+)	N/A	N/A	N/A	retract (VDC+)	N/A
3	extend (VDC+)	common	upper limit switch	N/A	retract (VDC+)	lower limit switch

Cable Exit

1 = Top end socket

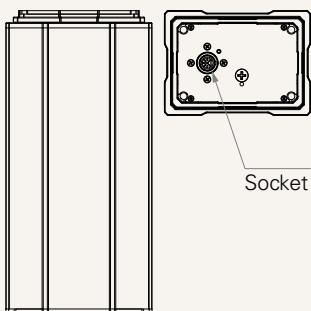

2 = Bottom side cable

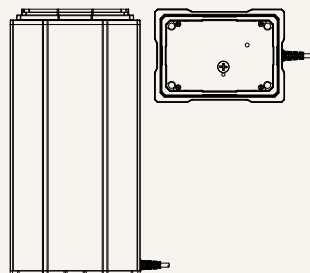

3 = Top side cable

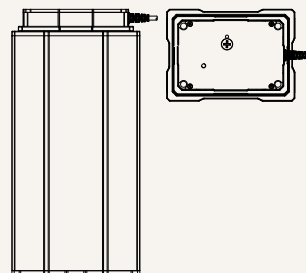

B = Top side - for TH; Bottom side - for TP

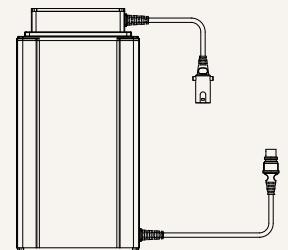

C = Bottom side- Y cable, for TH + TP

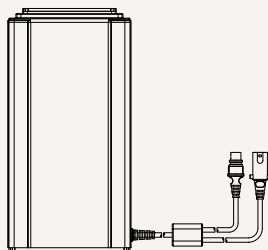

D = Top side - for the 2nd column; Bottom side - for TH & TP; direct cut operation with 2 columns

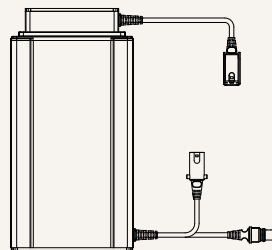

E = Top side - for the 2nd column & TH; Bottom side - for TP; direct cut operation with 2 columns

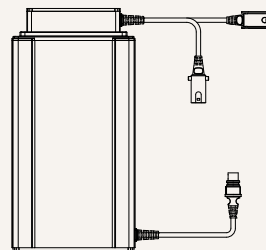

Connector

1 = DIN 6P, socket

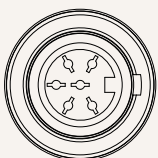

1 = DIN 6P, 90° plug

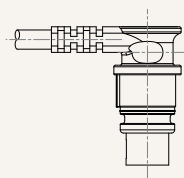

2 = Tinned leads

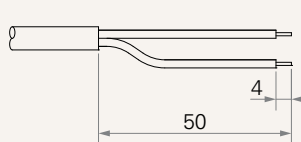

E = Molex 8P, plug

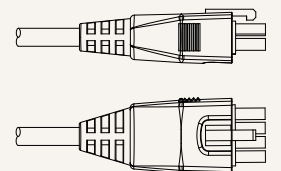

F = DIN 6P, 180° plug

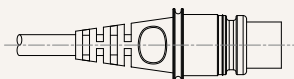

Connector

C = Direct cut, water proof, anti-pull

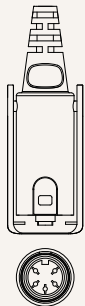

接TH：
長DIN 5P (Pin腳排列240°)，
180°插座 (帶防拉扣)

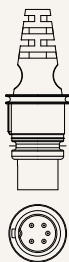

接TP：
長DIN 5P (Pin腳排列240°)，
180°插座 (帶O型環)

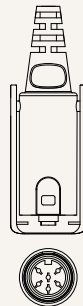

接Column 2：
長DIN 6P (Pin腳排列240°)，
180°插座 (帶防拉扣)

Cable Length (mm)

B = Cable exit #B, L2 = L3 = 100

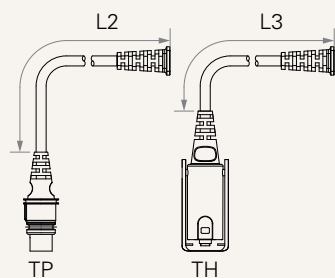

C = Cable exit #C, L1 = L2 = L3 = 100

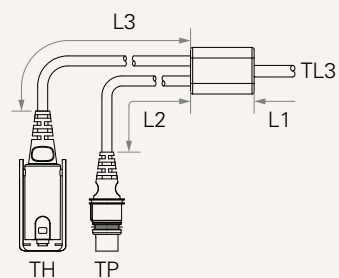

D, E = Cable exit #D, #E, L2 = L3 = L4 = 100

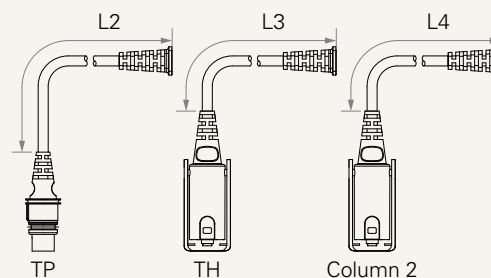

Tubes Direction

0 = Thinner on top

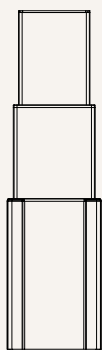

1 = Wider on top

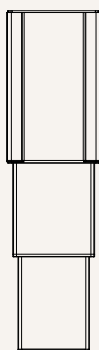

Terms of Use

The user is responsible for determining the suitability of TiMOTION products for a specific application. TiMOTION products are subject to change without prior notice.