

# TVL3

series



## Product Segments

- **Comfort Motion**
- **Ergo Motion**

The TiMOTION TVL3 series columns are primarily designed as TV lifts, but can be used in other applications that require vertical movement using a remote control. Our steel constructed TVL3 is available in three sizes depending on the requirements of the application. An extended height position can be programmed using our remote control.

### General Features

Max. load	600N (push)
Max. speed at max. load	22mm/s
Max. speed at no load	32mm/s
Retracted length	570mm
Dimension of outer tube	3-stage, 120*70 mm
Certificate	RoHS
Adjustable stroke (preset in factory)	
Adjustable mounting bracke	

Drawing

Standard Dimensions  
(mm)

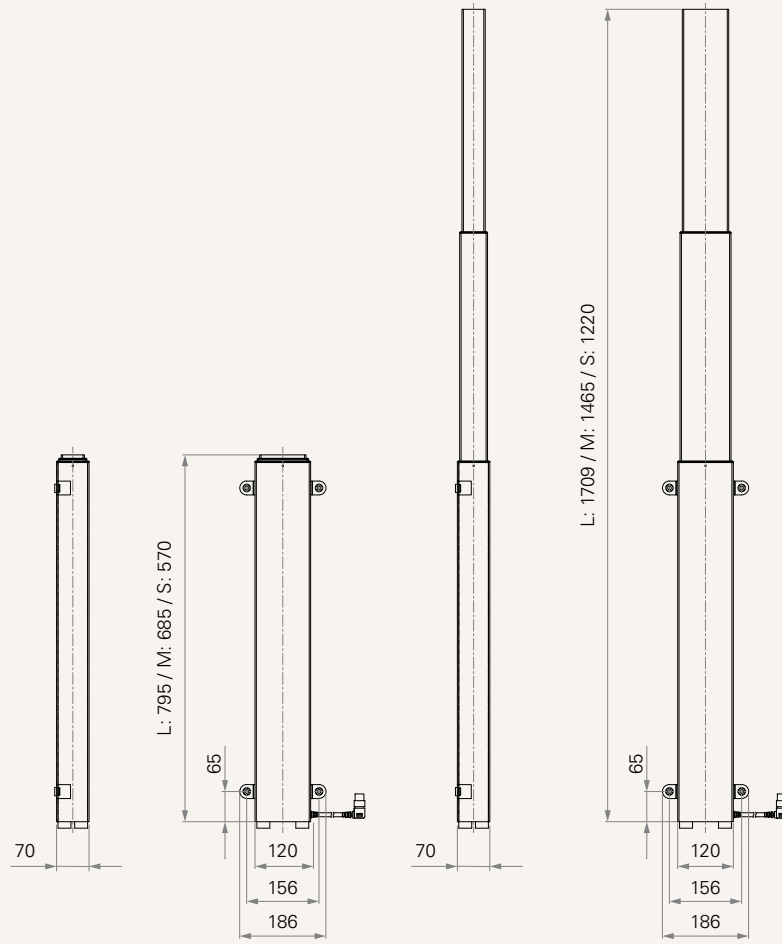

### System Overview

The TL is designed especially for push applications, not suitable for pull applications.

Column: TVL3

Control Box: TC11

Controls: TH3 and IR Control

Accessories: TJB2, TSS (optional), IR receiver, and concealed switch box

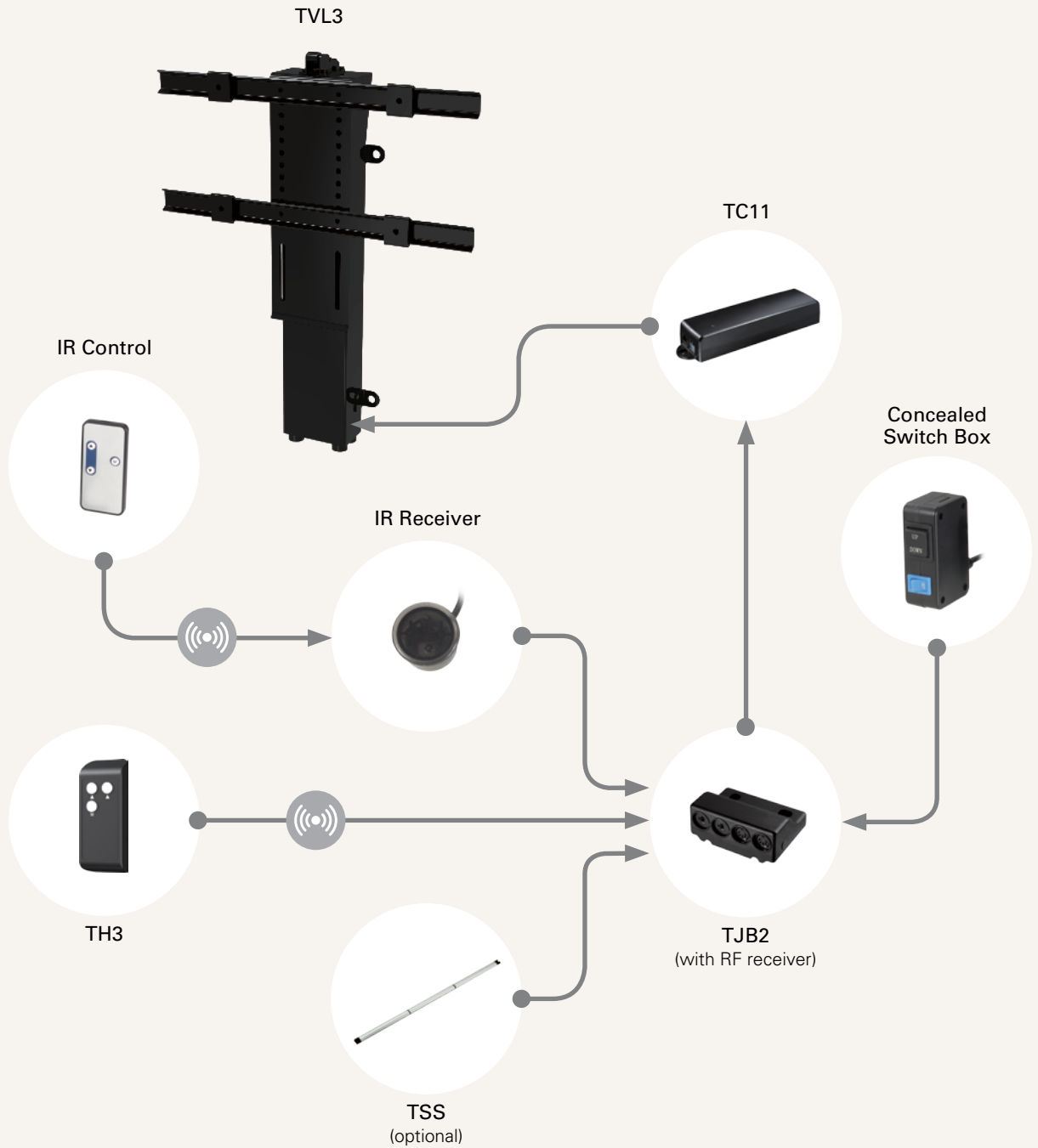

## TVL3

Version: 20150716-B

<b>Retracted Length (mm)</b>	L = Stroke 914, retracted length 795 M = Stroke 780, retracted length 685	S = Stroke 650, retracted length 570		
<b>Plug</b>	E = Molex 8PIN Note: The cable length of motor is 1350mm			
<b>Color</b>	1 = Black			
<b>Accessories Spec</b>	0 = Without	L = "L" type	M = "M" type	S = "S" type
<b>Logo</b>	0 = Without	1 = T-MOTION Logo		
<b>Packaging</b>	0 = Without	1 = With partition board		

### Terms of Use

The user is responsible for determining the suitability of TiMOTION products for a specific application. TiMOTION products are subject to change without prior notice.