

User Manual

JP3

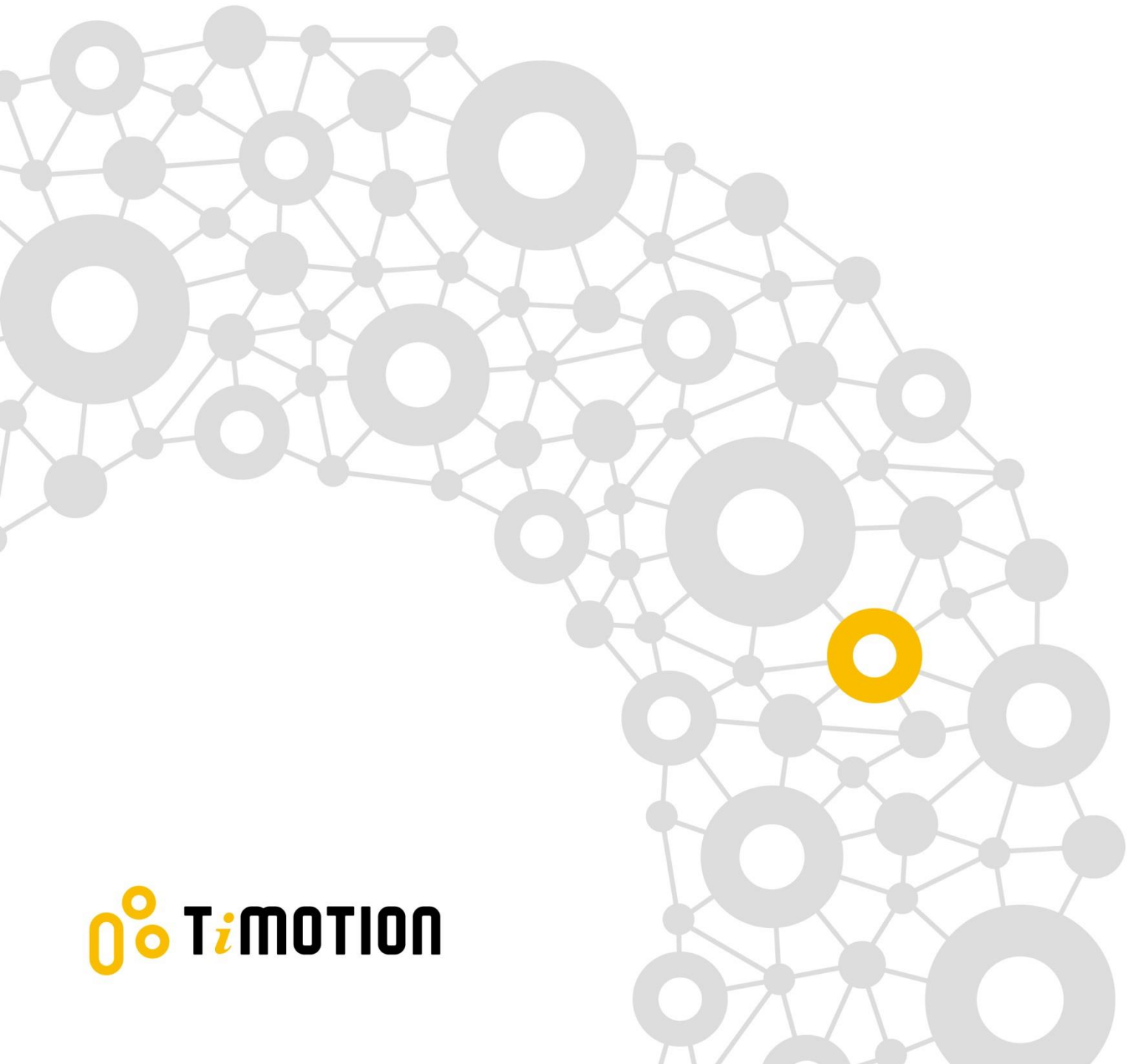

00 TiMOTION

Contents

Contents	2
Glossary	3
1. General	4
1.1 About this manual	4
1.2 Target Personnel	4
1.3 Warranty.....	4
1.4 Transport and storage.....	4
1.5 Packaging	5
1.6 Support	5
1.7 Disclaimer	5
1.8 Notification and warnings.....	5
1.8.1 Mounting/dismounting the actuator.....	5
1.8.2 Operation.....	6
1.8.3 Equipment power off	6
1.8.4 Duty cycle.....	6
1.8.5 Temperature.....	6
2. Installation	7
2.1 Mechanical installation.....	7
2.1.1 Mounting notice.....	7
2.2 Electrical installation	8
2.2.1 Important notice	8
2.2.2 Cable	9
2.2.3 Inrush current.....	10
2.3 Wiring definitions.....	11
2.3.1 Limitations for limit switches / output signals	11
2.3.2 Two limit switches to cut the current (without signal output)	12
2.3.3 Two limit switches to cut the current and an additional limit switch for signal output	13
2.3.4 Two limit switches send the signal and an additional limit switch sends a signal at specific stroke positions.....	14
2.3.5 Two limit switches send the signal output	15
2.3.6 Two limit switches and a single Hall sensor	16
2.3.7 Two limit switches and double Hall sensors.....	17
3. Product specifications	18
3.1 2D drawings.....	18
3.2 Ordering key.....	19
4. Troubleshooting	20

Glossary

The following terms and acronyms are being used in this manual.

- **Vm+**: The positive pole of power input.
- **Vm-**: The negative pole of power input.
- **RPM**: Number of turns per minute.
- **AWG**: American wiring gauge.
- **LS**: Limit switch installed inside the outer tube.
- **Up LS**: Upper limit switch is installed in fully extended end of stroke.
- **Low LS**: Lower limit switch is installed in fully retracted end of stroke.
- **Mid LS**: Middle limit switch is installed and the position is set by customer's request.
- **N.C.:** It is the pin of limit switch which is normally short circuit and changed to open when the switch is triggered.
- **N.O.:** It is the pin of limit switch which is normal open and changed to short circuit when the switch is triggered.
- **C.:** It is the common pin of limit switch when the circuit is either open or short.
- **Vp**: The reference voltage input to POT signal.
- **Vout**: The POT signal wire output value.

1. General

1.1 About this manual

This user manual is provided to the manufacturer of the equipment or system rather than end users. This manual provides information needed to install, use and maintain the TiMOTION products. Manufacturers are responsible to provide a user guide to the end users using the relevant safety information passed from this manual.

This manual contains installation directions as well as technical data for the TiMOTION industrial electric linear actuators. Carefully read through each section of the user manual before the equipment is unpacked, installed or operated. Please note all the dangers, warnings, cautions and notes stated in this manual. Please follow the instructions provided in this manual to ensure safe reliable operation.

1.2 Target Personnel

Please allow qualified mechanical and electrical professionals perform all installation, maintenance and replacement of the TiMOTION products. Please keep the products away from people who do not have the required experiences or knowledge of the product.

1.3 Warranty

In general, TiMOTION provides a 24 month warranty on Industrial Motion actuators based on the manufacturing date. The warranty is valid only if the equipment is properly operated and maintained correctly. The application of the product is the responsibility of the buyer. TiMOTION makes no representation or warranty as to the suitability of the product for any particular use or purpose.

1.4 Transport and storage

The actuator should only be stored and transported in the original TiMOTION packaging. The temperature during transportation and storage must be between -40 to +85° C (-40 to +185° F). Please avoid shocks to the package. If the package is damaged, check the actuator for visible damage and notify the carrier and TiMOTION.

1.5 Packaging

The sample order packaging contains the product and this manual. For large quantity orders, packaging may vary and TiMOTION reserves the right to change it.

1.6 Support

If any technical support or information is needed for this product, please contact your TiMOTION sales engineer. You can also visit <https://www.TiMOTION.com/en> for the product or contact information.

1.7 Disclaimer

This user manual has been written based on our current technical knowledge. TiMOTION is constantly working on updating the product information. We reserve the right to carry out technical modifications.

1.8 Notification and warnings

1.8.1 Mounting/dismounting the actuator

- ◆ Please read through this user manual before working on the equipment that the actuator is or shall be a part of.
- ◆ Adhere to the information contained in this user manual and on the product label. Never exceed the performance limits stated herein.
- ◆ Be sure the actuator is not in operation.
- ◆ Ensure the actuator is free from loads that could be released during mounting or dismounting.
- ◆ Refrain from unplugging any cables or connectors during operation or with power on.
- ◆ Immediately stop using the actuator if it seems faulty or damaged. Notify your TiMOTION sales engineer so corrective actions can be taken.
- ◆ Never disassemble the actuator, as that will compromise the sealing and could impact the function of the actuator. Disassembly voids warranty.
- ◆ Grease may be present on the extension tube. Contact with the grease is non-hazardous. Please refrain from removing the film.

1.8.2 Operation

- ◆ Be sure the actuator is correctly mounted as indicated in the user instructions.
- ◆ Be sure the equipment can be moved easily over the actuator's whole working area.
- ◆ Be sure the actuator is connected to a main electricity supply/transformer with the correct voltage, specified on the actuator label.
- ◆ Be sure that the connection bolts are secured safely and can withstand the wear.
- ◆ Stop the actuator immediately if anything unusual is observed.
- ◆ Ensure there is no side load present on the actuator.
- ◆ Only use the actuator within the specified working limits.
- ◆ Refrain from having any contact with the actuator.

1.8.3 Equipment power off

- ◆ Switch off the main supply to prevent any unintentional operation.
- ◆ Regularly check for extraordinary wear.

1.8.4 Duty cycle

- ◆ The standard duty cycle is 10%.
- ◆ If the product is customized, please refer to the approval drawings.

1.8.5 Temperature

- ◆ The operating temperature range is +5°C ~+65°C.
- ◆ The operational temperature range at full performance is +5°C ~+45°C.

2. Installation

2.1 Mechanical installation

2.1.1 Mounting notice

- ◆ Use solid mounting pins with the proper dimension and support them at both ends.

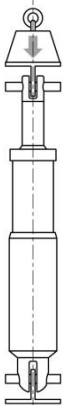
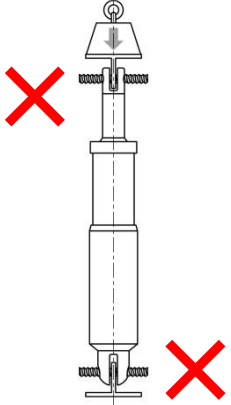
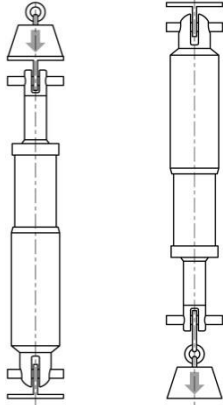
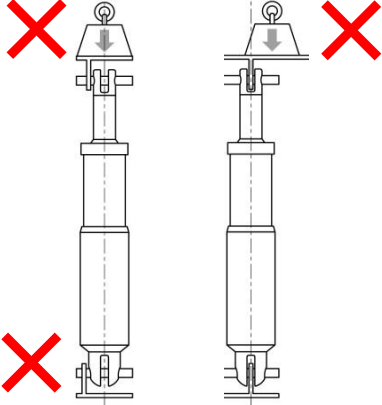
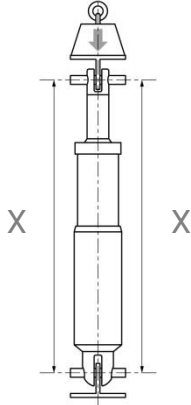
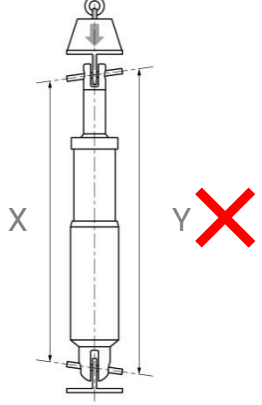
Note	Correct	Wrong
<p>Please mount the actuator with the mounting pins of correct dimension and without threaded at both ends of the attachments.</p>		
<p>Do not mount the actuator with the pins in different rotated angles, this could cause stress on the nut during operation.</p> <p>The load should act along the stroke axis of the actuator from the front attachment, inner tube to the rear attachment. Off center or side loads may cause bending and lead to failure.</p>		
<p>Be sure the mounting pins must be parallel to each other. If the pins are not parallel to each other the actuator might be bend and could be damaged.</p>		

2.2 Electrical installation

2.2.1 Important notice

- ◆ Make sure the leads/cables leading to the motor are rated to handle the maximum current.
- ◆ To reduce the chance of a crushing hazard, we recommend an emergency stop.
- ◆ If you are not using soft stop on a DC-motor, a short peak of high voltage will be sent towards the power supply. When selecting the power supply, please ensure it is able to withstand the peak of high voltage.
- ◆ To reduce the chance of interference, refrain from placing signal cables along power cables.
- ◆ Use a two-wire system to prevent ground loop.
- ◆ Please use shielded signal cables with applications that can be sensitive or if there is interference risk.
- ◆ Please note, using long cables in combination with small lead cross sections and low voltages could lead to a malfunction due to voltage drop.
- ◆ Use spark protection on relays and other coil operated devices.
- ◆ Please be sure the power to the actuator is off before working on the actuator and the wiring.

2.2.2 Cable

The actuator is supplied with a power cable (and/or signal cable). The standard cable, for industrial applications, has/have flying leads in the end for the user's equipment connections.

*Please refer to the approval drawing of any customized cable/connector.

Cable without signal:

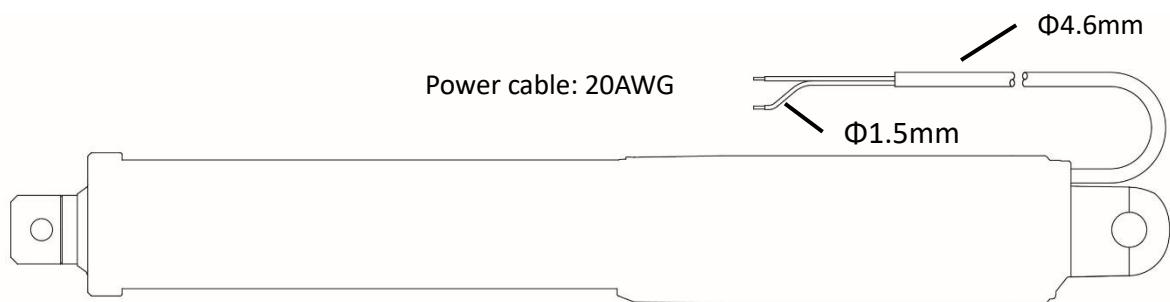

Cable with signal:

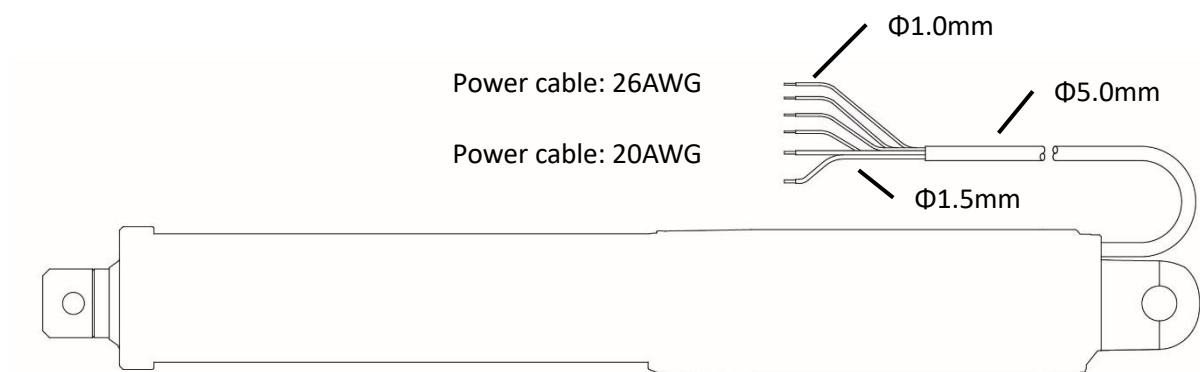

2.2.3 Inrush current

When the actuator starts to work, there is an inrush current to the motor that will be less than 0.2 seconds (up to four times the rated current).

Please select a power supply that is able to withstand the inrush current. Also, all contacts, including switches and relays, should be selected with caution.

2.3 Wiring definitions

Shown below are the standard wiring definitions of the actuator. If your actuator is ordered with customized wiring, please contact TiMOTION sales for detailed information.

2.3.1 Limitations for limit switches / output signals

In general, the JP3 cable can have a maximum of 6 pins– (2 power wire pins and/or up to 4 signal wire pins) The function limitations for limit switches to output signals are shown in the table below:

Functions for limit switches	Signal output			
	Without	POT	Single Hall	Double Hall
2 limit switches to cut the current	OK 2.3.2	OK 2.3.8	OK 2.3.6	OK 2.3.7
2 limit switches to cut the current one additional limit switch for signal output	OK 2.3.3	x	x	x
2 limit switches for signal output	OK 2.3.5	x	x	x
2 limit switches for signal output one additional limit switch for signal output	OK 2.3.4	x	x	x

* OK = Selectable

** x = Not Compatible

Note:

Please contact the TiMOTION sales engineer if the signal outputs are customized.

2.3.2 Two limit switches to cut the current (without signal output)

The actuator is equipped with two limit switches to cut the current of the motor when the actuator moves to the end of each stroke and without any output signal.

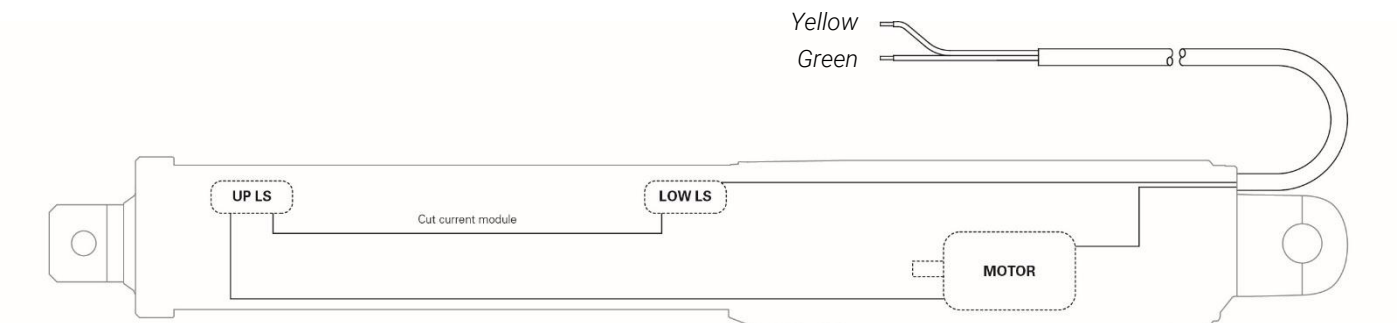

Wire	AWG	Description	Spec
Yellow	20	Connect to Vm+ to extend the actuator. Connect to Vm- to retract the actuator.	24V version: Input voltage 18~32 V DC. 12V version: Input voltage 9~16 V DC.
Green	20	Connect to Vm- to extend the actuator. Connect to Vm+ to retract the actuator.	

2.3.3 Two limit switches to cut the current and an additional limit switch for signal output

The actuator is equipped with two limit switches to cut the current of the motor when the actuator moves to the end of each stroke, and an additional limit switch sends out the signal at specific stroke positions.

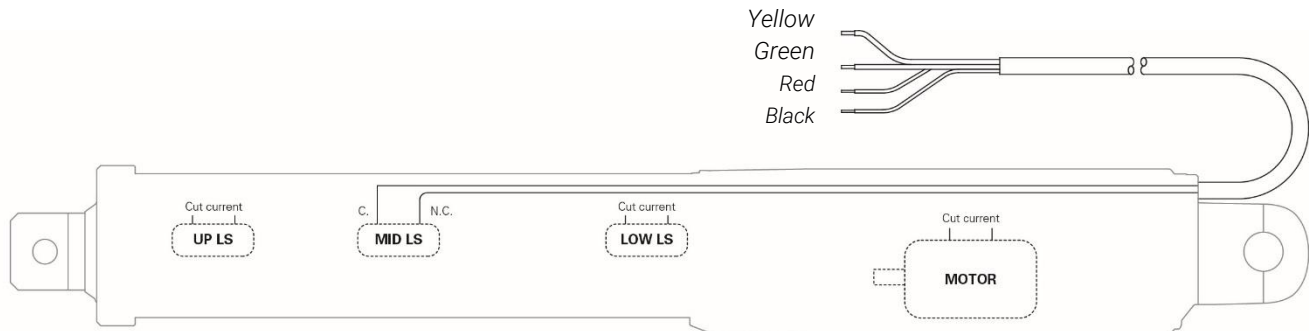

Wire	AWG	Description	Spec
Yellow	20	Connect to Vm+ to extend the actuator. Connect to Vm- to retract the actuator.	24V version: Input voltage 18~32 V DC. 12V version: Input voltage 9~16 V DC.
Green	20	Connect to Vm- to extend the actuator. Connect to Vm+ to retract the actuator.	
White	26	Connect to common pin (C.)	The signal is potential free and independent from the motor power circuit. The signal is short circuit when the actuator moves to the position where the middle limit switch is triggered. The middle limit switch is installed at the position upon customer's request and physically preset in factory which is not adjustable. The middle limit switch, installed in position by customer request, is factory preset and non-adjustable. Connect the middle limit switch signal with max 32V, <1A.
Black	26	Connect to normal closed pin (N.C.)	

2.3.4 Two limit switches send the signal and an additional limit switch sends a signal at specific stroke positions

The actuator is equipped with two limit switches at the end of the strokes. When the actuator moves to the end of each stroke, each limit switch sends out the end of stroke voltage signal and an additional limit switch sends out the signal at specific stroke positions.

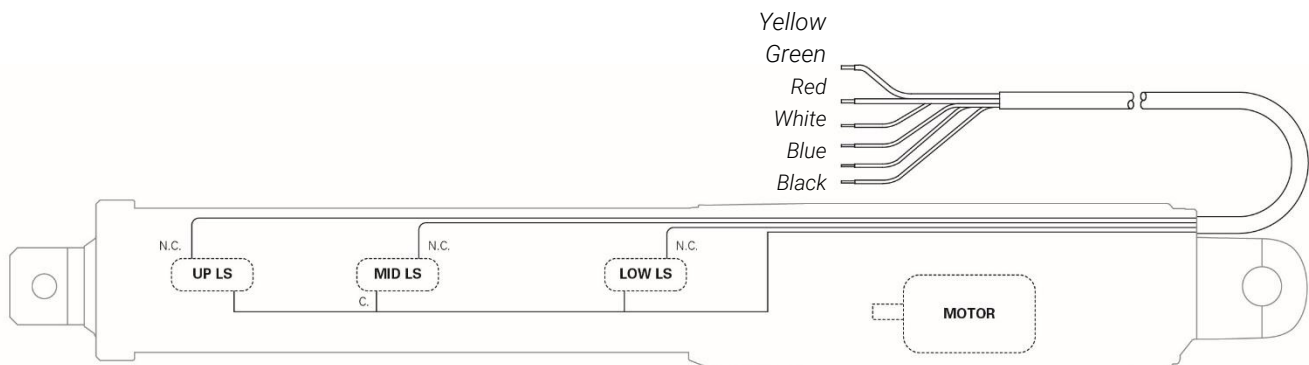

Wire	AWG	Description	Spec
Yellow	20	Connect to Vm+ to extend the actuator. Connect to Vm- to retract the actuator.	24V version: Input voltage 18~32 V DC. 12V version: Input voltage 9~16 V DC.
Green	20	Connect to Vm- to extend the actuator. Connect to Vm+ to retract the actuator.	
Red	26	Connect to common pin (C.)	The signal, NOT potential free, actively outputs voltage at the end of each stroke and when the actuator moves to the position where the middle limit switch is triggered. Both the white and blue signal wires are a normal closed circuit when the actuator is in the middle of the stroke. The middle limit switch, installed in position by customer request, is factory preset and non-adjustable Connect the middle limit switch signal with max 32V, <1A.
White	26	Connect to up limit switch normal closed pin (N.C.)	
Blue	26	Connect to low limit switch normal closed pin (N.C.)	
Black	26	Connect to middle limit switch normal closed pin (N.C.)	

2.3.5 Two limit switches send the signal output

The actuator is equipped with two limit switches. When the actuator moves to the end of each stroke, each limit switch sends out the end of stroke voltage signal at the same time.

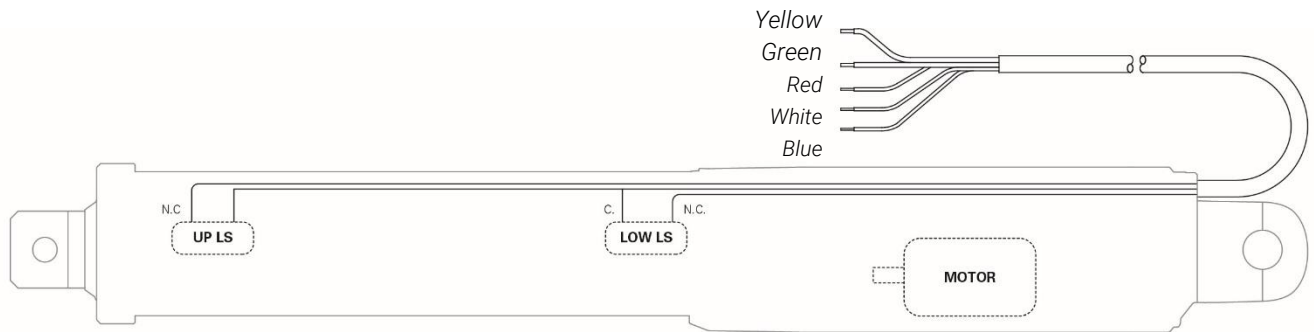

Wire	AWG	Description	Spec
Yellow	20	Connect to Vm+ to extend the actuator Connect to Vm- to retract the actuator	24V version: Input voltage 18~32 V DC 12V version: Input voltage 9~16 V DC
Green	20	Connect to Vm- to extend the actuator Connect to Vm+ to retract the actuator	
Red	26	Connect to common pin (C.)	The signal is potential free and independent from the motor power circuit.
White	26	Connect to up limit switch normal closed pin (N.C.)	The signal is short circuit when the actuator moves to each end of stroke.
Blue	26	Connect to low limit switch normal closed pin (N.C.)	Connect the limit switches signal with max 32V, <1A.

2.3.6 Two limit switches and a single Hall sensor

The actuator is equipped with two limit switches to cut the current of the motor when the actuator moves to the end of each stroke, and with a single Hall sensor sending position signal output.

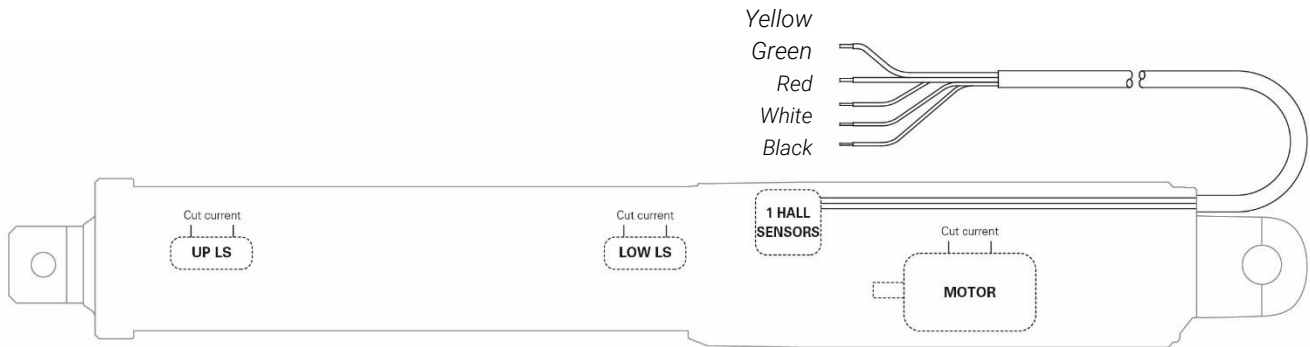

Wire	AWG	Description	Spec
Yellow	20	Connect to Vm+ to extend the actuator Connect to Vm- to retract the actuator	24V version: Input voltage 18~32 V DC 12V version: Input voltage 9~16 V DC
Green	20	Connect to Vm- to extend the actuator Connect to Vm+ to retract the actuator	
Red	26	+5V DC input signal power for Hall sensor board.	Hall sensor output signal type is square wave with Hi voltage 5V and Low voltage 0V, and with the output current of 0.1A (please refer to the approval drawing for the resolution and details).  Hall sensor circuit is independent to motor power circuit.
White	26	Output Hall sensor signal during the actuator moves.	
Black	26	Hall sensor signal ground.	

2.3.7 Two limit switches and double Hall sensors

The actuator is equipped with two limit switches to cut the current of the motor when the actuator moves to the end of each stroke, and with double Hall sensors sending position signal output.

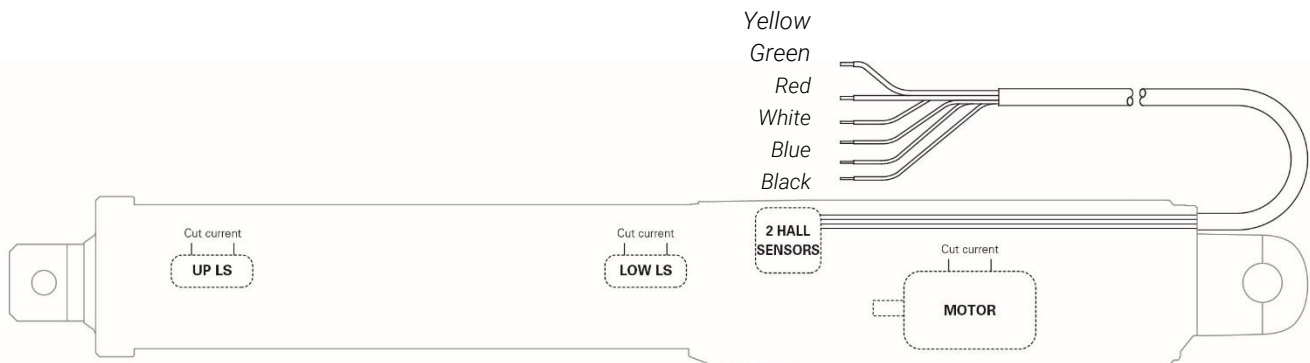

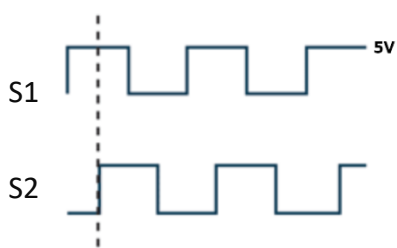
Wire	AWG	Description	Spec
Yellow	20	Connect to Vm+ to extend the actuator Connect to Vm- to retract the actuator	24V version: Input voltage 18~32 V DC 12V version: Input voltage 9~16 V DC
Green	20	Connect to Vm- to extend the actuator Connect to Vm+ to retract the actuator	
Red	26	+5V DC input signal power for Hall sensor board.	Hall sensor output signal type is square wave with Hi voltage 5V and Low voltage 0V, and with the output current of 0.1A (please refer to the approval drawing for the resolution and details). S1 leads 90 degrees' phase to S2. 
White	26	Output Hall sensor signal S1 during the actuator moves.	
Blue	26	Output Hall sensor signal S2 during the actuator moves.	
Black	26	Hall sensor signal ground.	
			Hall sensor circuit is independent to motor power circuit.

3.Product specifications

3.1 2D drawings

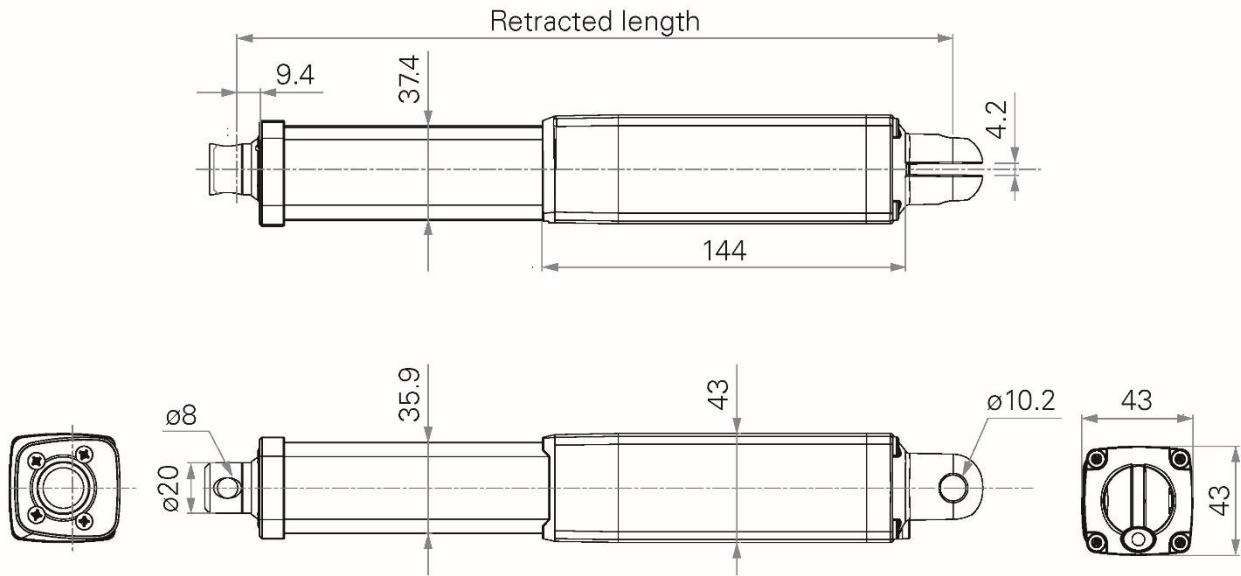

3.2 Ordering key

*Please contact your TiMOTION sales engineer for the latest revision ordering key.

JP3

Version: 20191204-E



Voltage	1 = 12V DC	2 = 24V DC	5 = 24V DC, PTC	6 = 12V DC, PTC
----------------	------------	------------	-----------------	-----------------

[See page 7](#)

Load and Speed	See page 2
-----------------------	----------------------------



Stroke (mm)	
--------------------	--

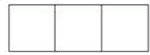

Retracted Length (mm)	See page 2
------------------------------	----------------------------



Rear Attachment (mm)	1 = Aluminum casting, U clevis, slot 4.2, depth 18.0, hole 10.2
-----------------------------	---

[See page 6](#)

Front Attachment (mm)	1 = Aluminum casting, no slot, hole 6.4 2 = Aluminum casting, no slot, hole 8.0 3 = Aluminum CNC, U clevis, slot 6.0, depth 13.0, hole 10.0 4 = Aluminum CNC, U clevis, slot 6.0, depth 13.0, hole 6.4 5 = Aluminum CNC, U clevis, slot 6.0, depth 13.0, hole 8.0 6 = Aluminum casting, hole 10.0
------------------------------	--

[See page 6](#)

Direction of Rear Attachment (Counterclockwise)	1 = 0°
--	--------

[See page 6](#)

Color	1 = Black	2 = Grey (Pantone 428C)
--------------	-----------	-------------------------



IP Rating	1 = Without	3 = IP66	6 = IP66D	8 = IP69K
	2 = IP54	5 = IP66W	7 = IP68	



Special Functions for Spindle Sub-Assembly	0 = Without (Standard)
---	------------------------



Functions for Limit Switches	1 = Two switches at full retracted / extended positions to cut current 2 = Two switches at full retracted / extended positions to cut current + 3rd LS to send signal 3 = Two switches at full retracted / extended positions to send signal 4 = Two switches at full retracted / extended positions to send signal + 3rd LS to send signal
-------------------------------------	--

[See page 7](#)

Output Signal	0 = Without	2 = Hall sensor * 2
----------------------	-------------	---------------------



Connector	1 = DIN 6P, 90° plug	2 = Tinned leads
------------------	----------------------	------------------

[See page 7](#)

Cable Length (mm)	0 = Straight, 100	1 = Straight, 500	3 = Straight, 1000
--------------------------	-------------------	-------------------	--------------------

4. Troubleshooting

Please find the table which lists the symptoms, possible cause and recommend action.

If the problem could not be solved, please contact your TiMOTION sales engineer.

Symptom	Possible cause	Action
Motor runs but spindle does not move	Gearing system or spindle damaged	Please contact your TiMOTION sales engineer.
No motor sound or movement	The actuator is not properly connected to the power supply	Check the connection to the power supply or the external control unit
	Customer fuse burned	Check the fuse
	Cable damaged	Please contact your TiMOTION sales engineer.
Excessive power consumption	Misalignment or overload in the application	Align or reduce the load Try running the actuator without load
Actuator cannot lift full load or motor runs too slowly	Insufficient power supply	Check the power supply is properly plugged in
	Load is higher than specified	Reduce the load
No signal or incorrect feedback output	Cable damaged	Please contact your TiMOTION sales engineer.
	Wrongly connected	Check the wiring
	Signal is constantly high/low	Run the actuator to full extension and retraction
		Reconnect the cables and set parallel configuration again