

TEK21

series

Product Segments

• Ergo Motion

General Features

Frame Orientation	Rectangular
Maximum Load	80kg
Constant Speed	(<80Kg)
3 Stage Column	33mm/s
Weight of TEK21 Package	31Kg*
	*The actual weight of package may vary due to customer's selection of components.
Accessories (optional)	Enhanced anti-collision feature with t-touch, TFA1/3, TWC
Low Standby Power	<0.1W
Multiple control options	
High strength and stability – Steel construction	
Semi-Preassembled – Motor and control box are mounted within the frame	

Color (RAL Classic)

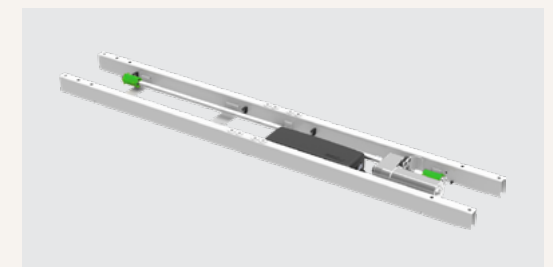
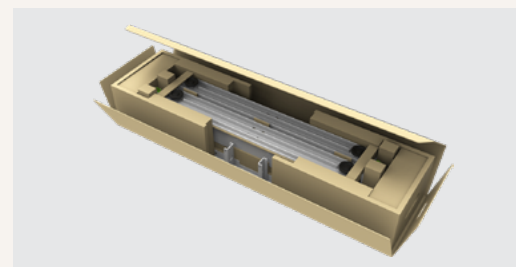
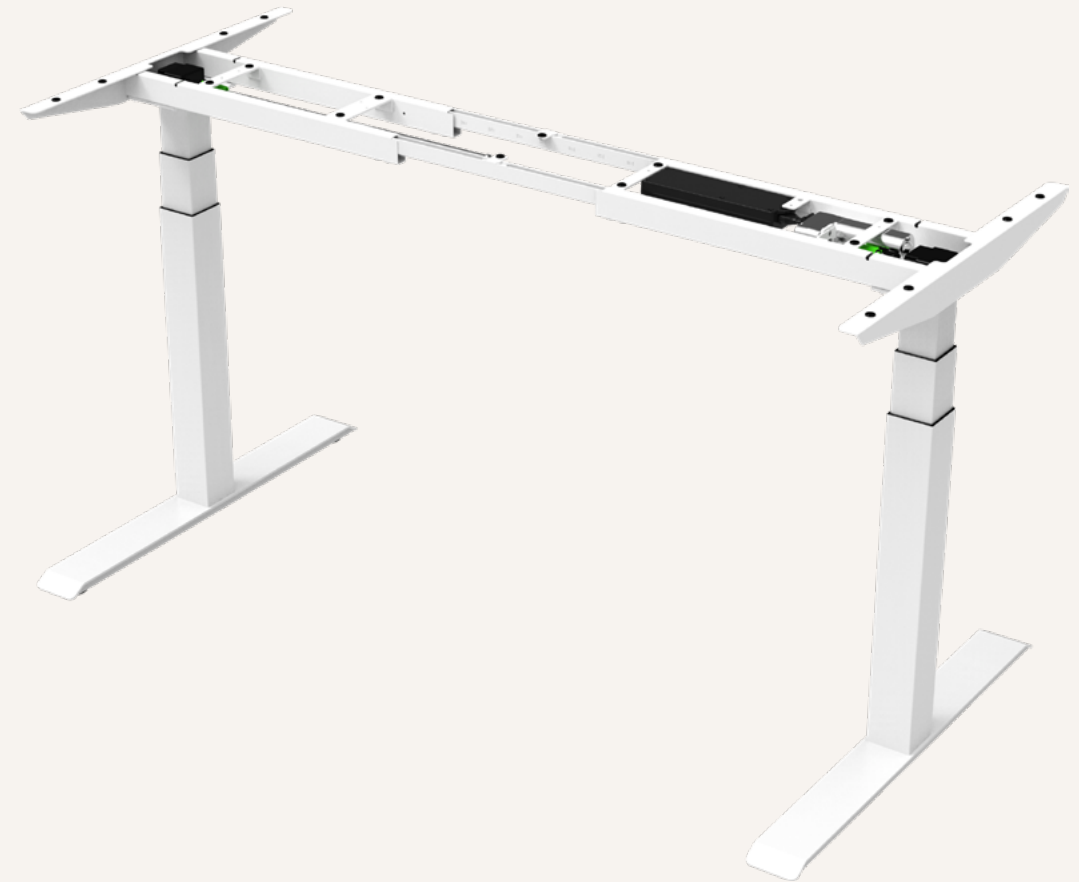
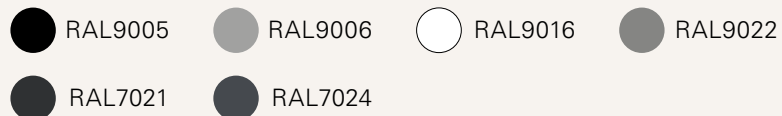

Drawing

Dimensions

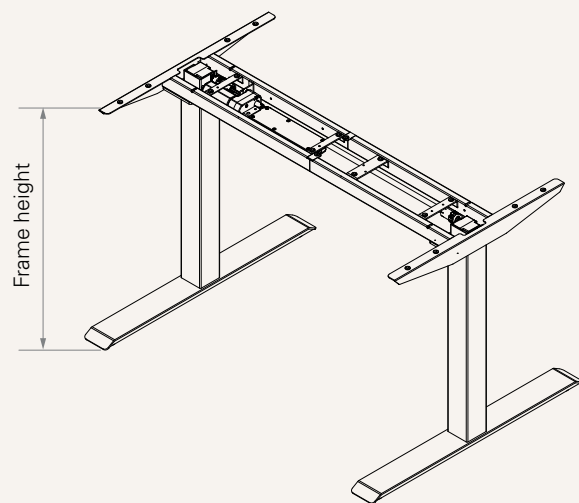
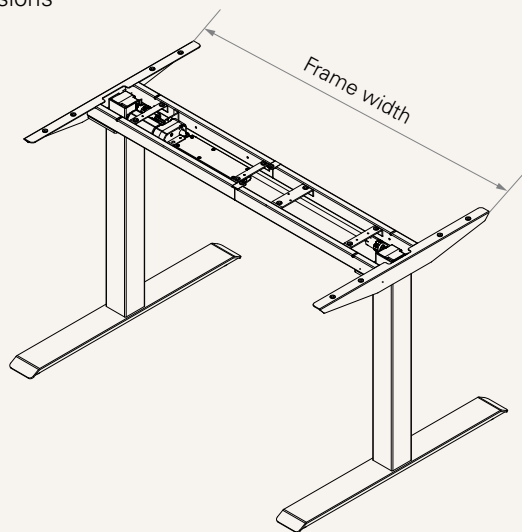

Frame Dimensions	Recommended Work Surface Dimensions	
Width (mm)	Width (mm)	Depth (mm)
1050~1600	1100~1700	700~1000

Column Type	Frame Height (mm)	Stroke (mm)
3-Stage	630~1280	650

Foot (mm)



Style A

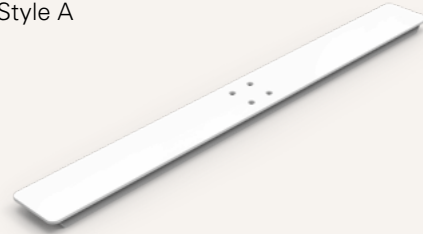

Style B

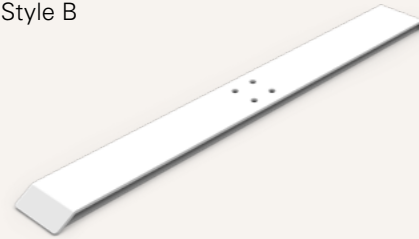

Style A (for C leg)



Style B (for C leg)

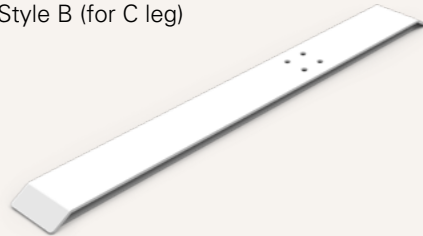

Style C



Style D

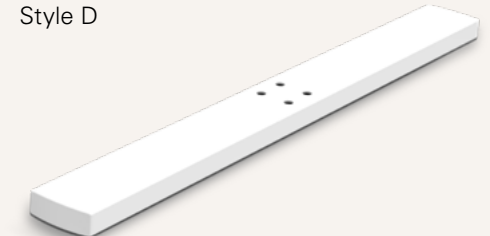

Code	Style	Thickness	Length (mm)	Code	Style	Thickness	Length (mm)
1	A	8	750	G	B	5	680
2	A	5	750	H	B	8	550
3	B	5	750	L	D	Tube	550
4	B	8	750	M	A	5	600
6	C	Aluminum extrusion	750	N	A	8	680
7	D	Tube	750	P	C	Aluminum extrusion	600
8	A	5	550	C-leg			
9	A	5	680	5	A	8	750
C	A	8	550	E	A	8	680
D	C	Aluminum extrusion	550	J	B	8	680
F	B	5	550	K	B	8	750

End Pipes (mm)



Style A
(for fixed tabletop)

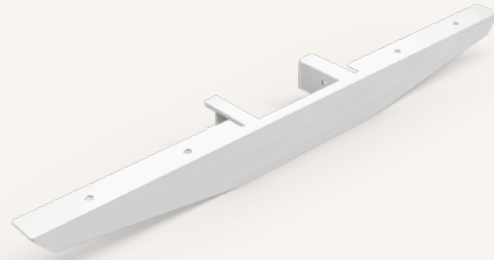

Style C
(for C leg, fixed tabletop)

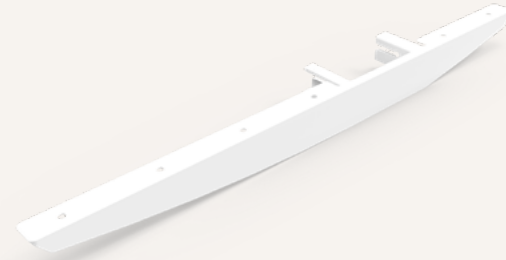

Handset Model



1 = TH37



2 = TFH8



3 = TDH1



4 = TDH2



5 = TDH3



6 = TDH4

Handset Model



7 = TDH5



8 = TDH6

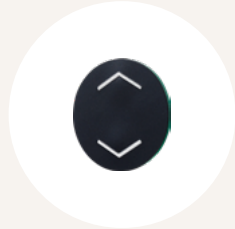

9 = TFH13



B = TH14



C = TFH21



D = TDH8P



E = TDH8



F = TDH8D



G = TDH11P



H = TDH12P



K = TDH16



L = TDH6PR



M = TDH5PR



N = TDH13P



P = TDH15



Q = TDH18P

Accessories (optional)



TCS1

TCS1 is a collision sensor based on t-touch technology which does not require any additional hardware upgrades.



TFA1

A charger with 2 USB ports. Can be mounted on the table top.



TFA3

A charger with 2 USB ports. Can be mounted to the desk front side.



TWC

Designed for wireless charging of mobile devices. Can be mounted on the table top.

Load and Speed	B Note: please contact TiMOTION before making an order							
Stroke & Retracted Length (mm)	650 & 620							
Foot (mm)	See page 3							
Color	1 = Black (RAL 9005), wiper: black		4 = Special grey (RAL 9022), wiper: black		8 = Special grey (RAL 9022), wiper: grey			
	2 = Grey(RAL9006), wiper: black		6 = Grey(RAL9006), wiper: grey		B = Matte black, RAL 7021, wiper: black			
	3 = White (RAL 9016), wiper: black		7 = White (RAL 9016), wiper: white		C = Graphite grey (RAL7024), wiper: black			
TC	1 = TC11							
Hand Control See page 4-5	0 = Without	3 = TDH1	6 = TDH4	9 = TFH13	D = TDH8P	G = TDH11P	L = TDH6PR	P = TDH15
	1 = TH37	4 = TDH2	7 = TDH5	B = TH14	E = TDH8	H = TDH12P	M = TDH5PR	Q = TDH18P
	2 = TFH8	5 = TDH3	8 = TDH6	C = TFH21	F = TDH8D	K = TDH16	N = TDH13P	
End Pipe (mm) See page 4	1 = Style A, fixation holes, E1 & E2: 600, Standard			2 = Style C, fixation holes, E1 & E2: 700, for C leg		3 = Style C, fixation holes, E1 & E2: 650, for C leg		
Desk Frame (mm)	1 = Outer pipe 20*40, W: 1050-1600; U type connection pipe, standard							
Column Shape	1 = Square, 3 stage							
Welding Part	0 = Without	1 = Direction 1	2 = Direction 2	3 = Direction 3	4 = Direction 4			

Terms of Use

The user is responsible for determining the suitability of TiMOTION products for a specific application. TiMOTION products are subject to change without prior notice.